



# **VigorPro 5300**

## **Unified Security Firewall**

### **User's Guide**

**Version: 2.0**

**Date: 2008/05/29**

Copyright 2008 All rights reserved.

This publication contains information that is protected by copyright. No part may be reproduced, transmitted, transcribed, stored in a retrieval system, or translated into any language without written permission from the copyright holders. The scope of delivery and other details are subject to change without prior notice.

Microsoft is a registered trademark of Microsoft Corp.  
Windows, Windows 95, 98, Me, NT, 2000, XP and Explorer are trademarks of Microsoft Corp.  
Apple and Mac OS are registered trademarks of Apple Computer Inc.  
Other products may be trademarks or registered trademarks of their respective manufacturers.

## Safety Instructions and Approval

### Safety Instructions

- Read the installation guide thoroughly before you set up the router.
- The router is a complicated electronic unit that may be repaired only by authorized and qualified personnel. Do not try to open or repair the router yourself.
- Do not place the router in a damp or humid place, e.g. a bathroom.
- The router should be used in a sheltered area, within a temperature range of +5 to +40 Celsius.
- Do not expose the router to direct sunlight or other heat sources. The housing and electronic components may be damaged by direct sunlight or heat sources.
- Do not deploy the cable for LAN connection outdoor to prevent electronic shock hazards.
- Keep the package out of reach of children.
- When you want to dispose of the router, please follow local regulations on conservation of the environment.

### Warranty

We warrant to the original end user (purchaser) that the router will be free from any defects in workmanship or materials for a period of two (2) years from the date of purchase from the dealer. Please keep your purchase receipt in a safe place as it serves as proof of date of purchase. During the warranty period, and upon proof of purchase, should the product have indications of failure due to faulty workmanship and/or materials, we will, at our discretion, repair or replace the defective products or components, without charge for either parts or labor, to whatever extent we deem necessary to restore the product to proper operating condition. Any replacement will consist of a new or re-manufactured functionally equivalent product of equal value, and will be offered solely at our discretion. This warranty will not apply if the product is modified, misused, tampered with, damaged by an act of God, or subjected to abnormal working conditions. The warranty does not cover the bundled or licensed software of other vendors. Defects which do not significantly affect the usability of the product will not be covered by the warranty. We reserve the right to revise the manual and online documentation and to make changes from time to time in the contents hereof without obligation to notify any person of such revision or changes.

### Be a Registered Owner

Web registration is preferred. You can register your Vigor router via <http://www.draytek.com>.

### Firmware & Tools Updates

Please consult the DrayTek web site for more information on newest firmware, tools and documents. For more detailed information, please refer to <http://www.draytek.com>



Parts of the anti-virus features are powered by Kaspersky Lab ZAO. For more detailed information, please refer to <http://www.kaspersky.com>.

## European Community Declarations

Manufacturer: DrayTek Corp.  
Address: No. 26, Fu Shing Road, HuKou County, HsinChu Industrial Park, Hsin-Chu, Taiwan 303  
Product: VigorPro 5300 Series

DrayTek Corp. declares that VigorPro 5300 Series is in compliance with the following essential requirements and other relevant provisions of R&TTE Directive 1999/5/EEC.

The product conforms to the requirements of Electro-Magnetic Compatibility (EMC) Directive 2004/108/EC by complying with the requirements set forth in EN55022/Class A and EN55024/Class B.

The product conforms to the requirements of Low Voltage (LVD) Directive 2006/95/EC by complying with the requirements set forth in EN60950.

## Regulatory Information

### Federal Communication Commission Interference Statement

This equipment has been tested and found to comply with the limits for a Class B digital device, pursuant to Part 15 of the FCC Rules. These limits are designed to provide reasonable protection against harmful interference in a residential installation. This equipment generates, uses and can radiate radio frequency energy and, if not installed and used in accordance with the instructions, may cause harmful interference to radio communications. However, there is no guarantee that interference will not occur in a particular installation. If this equipment does cause harmful interference to radio or television reception, which can be determined by turning the equipment off and on, the use is encouraged to try to correct the interference by one of the following measures:

- Reorient or relocate the receiving antenna.
- Increase the separation between the equipment and receiver.
- Connect the equipment into an outlet on a circuit different from that to which the receiver is connected.
- Consult the dealer or an experienced radio/TV technician for help.

This device complies with Part 15 of the FCC Rules. Operation is subject to the following two conditions:

- (1) This device may not cause harmful interference, and
- (2) This device may accept any interference received, including interference that may cause undesired operation.

### Taiwanese BSMI (Bureau of Standards, Metrology and Inspection) A Warning:

Warning: This device might cause interference of radio frequency under the environment of dwelling. In such condition, the users might be asked to adopt some proper strategies.

Please visit [www.draytek.com/about\\_us/R\\_TTE\\_Certification.php](http://www.draytek.com/about_us/R_TTE_Certification.php).



This product is designed for the ISDN and 2.4GHz WLAN network throughout the EC region and Switzerland with restrictions in France. Please see the user manual for the applicable networks on your product.

# Table of Contents

## 1

<b>Preface .....</b>	<b>1</b>
1.1 Web Configuration Buttons Explanation .....	1
1.2 LED Indicators and Connectors .....	2
1.1.1 For VigorPro5300 .....	2
1.1.2 For VigorPro5300n .....	4
1.1.3 For VigorPro5300Vn .....	6
1.1.4 For VigorPro5300VS .....	8
1.1.5 For VigorPro5300VSn .....	10
1.3 Hardware Installation .....	12
1.4 ISDN Phone Adapter Installation .....	12

## 2

<b>Configuring Basic Settings .....</b>	<b>15</b>
2.1 Changing Password .....	15
2.2 Quick Start Wizard .....	17
2.2.1 PPPoE .....	18
2.2.2 PPTP .....	20
2.2.3 Static IP .....	21
2.2.4 DHCP .....	22
2.3 Online Status .....	23
2.4 Saving Configuration .....	25

## 3

<b>Advanced Web Configuration .....</b>	<b>27</b>
3.1 WAN .....	27
3.1.1 Basics of Internet Protocol (IP) Network .....	27
3.1.2 General Setup .....	28
3.1.3 Internet Access .....	30
3.1.4 Load-Balance Policy .....	37
3.2 LAN .....	39
3.2.1 Basics of LAN .....	39
3.2.2 General Setup .....	41
3.2.3 Static Route .....	43
3.2.4 VLAN .....	46
3.2.5 Bind IP to MAC .....	47
3.3 NAT .....	48
3.3.1 Port Redirection .....	49
3.3.2 DMZ Host .....	52
3.3.3 Open Ports .....	54
3.4 Objects Settings .....	56

3.4.1 IP Object .....	56
3.4.2 IP Group .....	58
3.4.3 Service Type Object .....	59
3.4.4 Service Type Group .....	60
3.4.5 Keyword Object .....	61
3.4.6 Keyword Group .....	62
3.4.7 File Extension Object .....	63
3.4.8 IM Object .....	65
3.4.9 P2P Object .....	67
3.4.10 Misc Object .....	69
3.5 CSM Profile .....	70
3.5.1 IM/P2P Filter Profile .....	71
3.5.2 URL Content Filter Profile .....	72
3.5.3 Web Content Filter Profile .....	75
3.6 Firewall .....	76
3.6.1 Basics for Firewall .....	76
3.6.2 General Setup .....	79
3.6.3 Filter Setup .....	84
3.6.4 DoS Defense .....	91
3.7 Defense Configuration .....	94
3.7.1 Anti-Intrusion .....	94
3.7.2 Anti-Virus .....	98
3.7.3 Anti-Spam .....	103
3.7.4 Activation Anti-Intrusion/Anti-Virus/Anti-Spam Service .....	106
3.7.5 Signature Upgrade .....	107
3.7.6 Status .....	109
3.8 Bandwidth Management .....	110
3.8.1 Sessions Limit .....	110
3.8.2 Bandwidth Limit .....	111
3.8.3 Quality of Service .....	113
3.9 Applications .....	120
3.9.1 Dynamic DNS .....	120
3.9.2 Schedule .....	122
3.9.3 RADIUS .....	124
3.9.4 UPnP .....	125
3.9.5 IGMP .....	127
3.9.6 Wake on LAN .....	127
3.10 VPN and Remote Access .....	129
3.10.1 Remote Access Control .....	129
3.10.2 PPP General Setup .....	130
3.10.3 IPSec General Setup .....	131
3.10.4 IPSec Peer Identity .....	132
3.10.5 Remote Dial-in User .....	134
3.10.6 LAN to LAN .....	138
3.10.7 Connection Management .....	146
3.11 Certificate Management .....	147
3.11.1 Local Certificate .....	147
3.11.2 Trusted CA Certificate .....	149
3.11.3 Certificate Backup .....	150
3.12 VoIP .....	150
3.12.1 DialPlan .....	151
3.12.2 SIP Accounts .....	159

3.12.3 Phone Settings .....	163
3.12.4 Status.....	178
3.13 ISDN.....	179
3.13.1 Basic Concept.....	179
3.13.2 General Settings.....	180
3.13.3 Dial to a Single ISP/Dial to Dual ISPs .....	183
3.13.4 Call Control .....	186
3.14 Wireless LAN .....	188
3.14.1 Basic Concepts.....	188
3.14.2 General Setup.....	190
3.14.3 Security.....	192
3.14.4 Access Control.....	194
3.14.5 WPS.....	195
3.14.6 WDS.....	197
3.14.6 AP Discovery .....	200
3.14.7 Station List .....	201
3.14.8 Rate Control.....	202
3.15 SSL VPN .....	203
3.15.1 SSL Web Proxy .....	203
3.15.2 User Account .....	205
3.15.3 Online User Status.....	206
3.16 System Maintenance.....	208
3.16.1 System Status.....	208
3.16.2 Administrator Password.....	209
3.16.3 Configuration Backup .....	209
3.16.4 Syslog/Mail Alert .....	211
3.16.5 Time and Date .....	214
3.16.6 Management.....	215
3.16.7 Reboot System .....	216
3.16.8 Firmware Upgrade .....	217
3.17 Diagnostics.....	218
3.17.1 Dial-out Trigger .....	218
3.17.2 Routing Table .....	219
3.17.3 ARP Cache Table .....	219
3.17.4 DHCP Table.....	220
3.17.5 NAT Sessions Table .....	220
3.17.6 Data Flow Monitor.....	221
3.17.7 Traffic Graph.....	222
3.17.8 Ping Diagnosis.....	223
3.17.9 Trace Route .....	224

## 4

<b>Registration for the Router .....</b>	<b>225</b>
4.1 Creating and Activating an Account from VigorPro Website .....	225
4.2 Creating and Activating an Account from Router Web Configurator.....	229
4.3 Registering Your Vigor Router .....	234
4.4 Activating Anti-Virus/Anti-Intrusion/Anti-Spam Service .....	237
4.4.1 For Anti-Virus and Anti-Intrusion Service .....	237
4.4.2 For Anti-Spam Service.....	242
4.5 Applying a New License for Anti-Intrusion/Anti-Virus .....	251

4.6 Backup and Upgrade Signature for Anti-Intrusion/Anti-Virus .....	256
4.7 Switching between DT-DT and DT-KL .....	257
4.8 Enabling Anti-Virus/Anti-Intrusion/Anti-Spam.....	259

## 5

### **Application and Examples .....261**

5.1 Create a LAN-to-LAN Connection Between Remote Office and Headquarter .....	261
5.2 Create a Remote Dial-in User Connection Between the Teleworker and Headquarter.....	268
5.3 QoS Setting Example.....	272
5.4 LAN – Created by Using NAT .....	275
5.5 Calling Scenario for VoIP function .....	278
5.5.1 Calling via SIP Sever .....	278
5.5.2 Peer-to-Peer Calling .....	280
5.6 Upgrade Firmware for Your Router .....	281
5.7 Request a certificate from a CA server on Windows CA Server.....	283
5.8 Request a CA Certificate and Set as Trusted on Windows CA Server .....	287

## 6

### **Trouble Shooting .....289**

6.1 Checking If the Hardware Status Is OK or Not.....	289
6.2 Checking If the Network Connection Settings on Your Computer Is OK or Not .....	289
6.3 Pinging the Router from Your Computer .....	292
6.4 Checking If the ISP Settings are OK or Not.....	293
6.5 Backing to Factory Default Setting If Necessary .....	295
6.6 Contacting Your Dealer .....	296





# 1

## Preface

VigorPro 5300 is a broadband router with dual-WAN interface. It provides policy-based load-balance, fail-over and BOD (Bandwidth on Demand), also it integrates IP layer QoS, NAT session/bandwidth management to help users control works well with large bandwidth.

By adopting hardware-based VPN platform, hardware encryption of AES/DES/3DS and hardware key hash of SHA-1/MD5, the router increases the performance of VPN greatly, and offers several protocols (such as IPSec/PPTP/L2TP) with up to 100 VPN tunnels.

The object-originated design used in SPI (Stateful Packet Inspection) firewall allows users to set firewall policy with ease. CSM (Content Security Management) provides users control and management in IM (Instant Messenger) and P2P (Peer to Peer) more efficiency than before. By the way, DoS/DDoS prevention and URL/Web content filter strengthen the security outside and control inside.

Object-based firewall is flexible and allows your network be safe. In addition, through VoIP function, the communication fee for you and remote people can be reduced.

### 1.1 Web Configuration Buttons Explanation

Several main buttons appeared on the web pages are defined as the following:

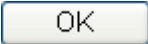
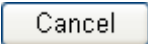
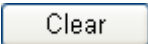
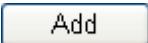
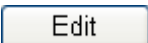
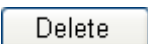
	Save and apply current settings.
	Cancel current settings and recover to the previous saved settings.
	Clear all the selections and parameters settings, including selection from drop-down list. All the values must be reset with factory default settings.
	Add new settings for specified item.
	Edit the settings for the selected item.
	Delete the selected item with the corresponding settings.

**Note:** For the other buttons shown on the web pages, please refer to Chapter 3 for detailed explanation.

## 1.2 LED Indicators and Connectors

### 1.1.1 For VigorPro5300

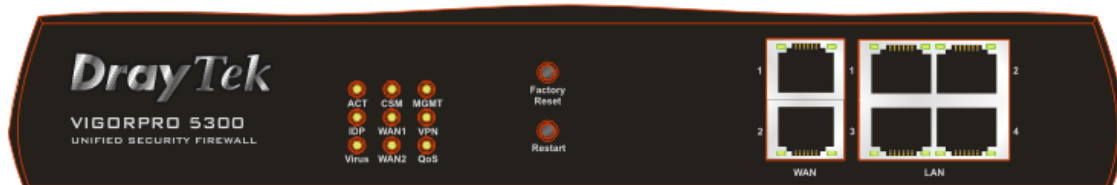

LED	Status	Explanation
ACT (Activity)	Blinking	The router is powered on and running normally.
	Off	The router is powered off.
IDP (Intrusion Detection and Prevention)	On (Yellow)	The anti-intrusion function is enabled.
Virus	On (Yellow)	The anti-virus function is enabled.
CSM	On	The profile of CSM (Content Security Management) for IM/P2P, URL content filter and/or Web content filter application is enabled from <b>Firewall &gt;&gt; General Setup</b> or <b>Filter Setup</b> . (Such profile is established under <b>CSM</b> menu).
WAN1/2	On	The WAN1 or WAN2 port is connected.
	Blinking	It will blink while transmitting data.
MGMT	On	The router is managed by Telnet.
	Blinking	It will blink while being managed by IE browser.
VPN	On	The VPN tunnel is launched.
	Off	The VPN tunnel is closed.
QoS	On	The QoS function is active.

#### *LED on Connector*

WAN 1/2	Left LED	On	The port is connected.
		Off	The port is disconnected.
		Blinking	The data is transmitting.
	Right LED	On	The port is connected with 100Mbps.
		Off	The port is connected with 10Mbps
LAN 1/2/3/4	Left LED	On	The port is connected.
		Off	The port is disconnected.
		Blinking	The data is transmitting.
	Right LED	On	The port is connected with 100Mbps.
Off		The port is connected with 10Mbps	

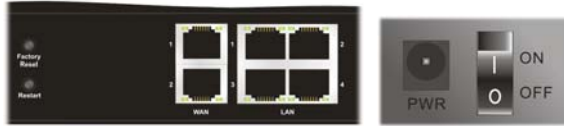

Interface	Description
Factory Reset	Restore the default settings. Usage: Turn on the router (ACT LED is blinking). Press the hole and keep for more than 5 seconds. When you see the ACT LED begins to blink rapidly than usual, release the button. Then the router will restart with the factory default configuration.
Restart	Restart the router forcefully.
WAN(1/2)	Connecters for remote networked devices.
LAN (1-4)	Connecters for local networked devices.
PWR	Connector for a power adapter.
ON/OFF	Power Switch.

## 1.1.2 For VigorPro5300n



LED	Status	Explanation
ACT (Activity)	Blinking	The router is powered on and running normally.
	Off	The router is powered off.
IDP (Intrusion Detection and Prevention)	On (Yellow)	The anti-intrusion function is enabled.
Virus	On (Yellow)	The anti-virus function is enabled.
WLAN	On	Wireless access point is ready.
	Blinking	It will blink slowly while wireless traffic goes through. If ACT and WLAN LEDs blink quickly and simultaneously when WPS is working, and it will return to normal condition after two minutes. (You need to setup WPS within 2 minutes.)
WAN1/2	On	The WAN1 or WAN2 connection is ready.
	Blinking	It will blink while transmitting data.
MGMT	On	The router is managed (handled) by Telnet.
	Blinking	It will blink while being managed by IE browser.
VPN	On	The VPN tunnel is active.
QoS	On	The QoS function is active.

### LED on Connector

WAN 1/2	Left LED (Green)	On	The port is connected.
		Off	The port is disconnected.
		Blinking	The data is transmitting.
	Right LED (Green)	On	The port is connected with 100Mbps.
		Off	The port is connected with 10Mbps.
		Blinking	The data is transmitting.
LAN 1/2/3/4	Left LED (Green)	On	The port is connected.
		Off	The port is disconnected.
		Blinking	The data is transmitting.
	Right LED (Green)	On	The port is connected with 100Mbps.
		Off	The port is connected with 10Mbps.
		Blinking	The data is transmitting.

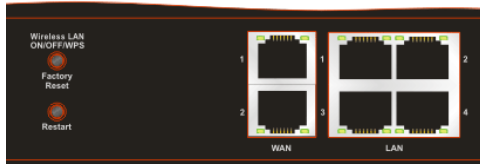

Interface	Description
Wireless LAN ON/OFF/WPS Factory Reset	Press "Wireless LAN ON/OFF/WPS" button for 2 seconds to wait for client device making network connection through WPS. Press "Wireless LAN ON/OFF/WPS" button once to enable (WLAN LED on) or disable (WLAN LED off) wireless connection. Restore the default settings. Usage: Turn on the router (ACT LED is blinking). Press the hole and keep for more than 5 seconds. When you see the ACT LED begins to blink rapidly than usual, release the button. Then the router will restart with the factory default configuration.
Restart	Restart the router forcefully.
Phone (1/2)	Connecters for PSTN phones.
WAN (1/2)	Connecters for remote networked devices.
LAN (1-4)	Connecters for local networked devices.
PWR	Connector for a power adapter.
ON/OFF	Power Switch.

### 1.1.3 For VigorPro5300Vn

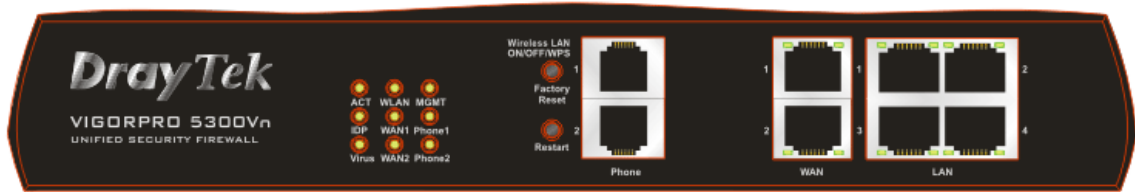

LED	Status	Explanation
ACT (Activity)	Blinking	The router is powered on and running normally.
	Off	The router is powered off.
IDP (Intrusion Detection and Prevention)	On (Yellow)	The anti-intrusion function is enabled.
Virus	On (Yellow)	The anti-virus function is enabled.
WLAN	On	Wireless access point is ready.
	Blinking	It will blink slowly while wireless traffic goes through. If ACT and WLAN LEDs blink quickly and simultaneously when WPS is working, and it will return to normal condition after two minutes. (You need to setup WPS within 2 minutes.)
WAN1/2	On	The WAN1 or WAN2 connection is ready.
	Blinking	It will blink while transmitting data.
MGMT	On	The router is managed by Telnet.
	Blinking	It will blink while being managed by IE browser.
Phone 1/2	On	The phone connected to this port is off-hook.
	Off	The phone connected to this port is on-hook.
	Blinking	A phone call comes.

#### LED on Connector

WAN 1/2	Left LED (Green)	On	The port is connected.
		Off	The port is disconnected.
		Blinking	The data is transmitting.
Right LED (Green)	On	The port is connected with 100Mbps.	
	Off	The port is connected with 10Mbps.	
LAN 1/2/3/4	Left LED (Green)	On	The port is connected.
		Off	The port is disconnected.
		Blinking	The data is transmitting.
	Right LED (Green)	On	The port is connected with 100Mbps.
Off		The port is connected with 10Mbps.	

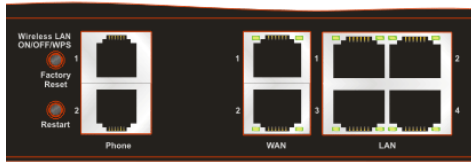

Interface	Description
Wireless LAN ON/OFF/WPS	Press "Wireless LAN ON/OFF/WPS" button for 2 seconds to wait for client device making network connection through WPS.
Factory Reset	Press "Wireless LAN ON/OFF/WPS" button once to enable (WLAN LED on) or disable (WLAN LED off) wireless connection.
Restart	Restore the default settings. Usage: Turn on the router (ACT LED is blinking). Press the hole and keep for more than 5 seconds. When you see the ACT LED begins to blink rapidly than usual, release the button. Then the router will restart with the factory default configuration.
Phone (1/2)	Restart the router forcefully.
WAN (1/2)	Connecters for PSTN phones.
LAN (1-4)	Connecters for remote networked devices.
PWR	Connecters for local networked devices.
ON/OFF	Connector for a power adapter.
	Power Switch.

## 1.1.4 For VigorPro5300VS

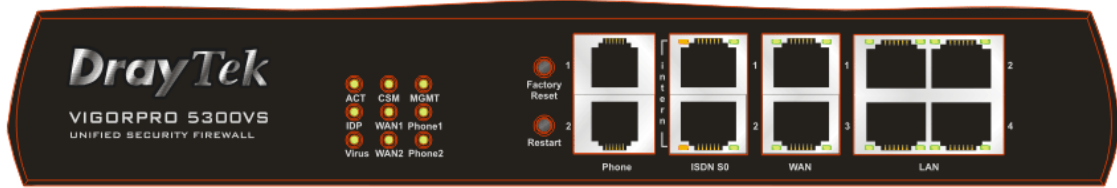

LED	Status	Explanation
ACT (Activity)	Blinking	The router is powered on and running normally.
	Off	The router is powered off.
IDP (Intrusion Detection and Prevention)	On (Yellow)	The anti-intrusion function is enabled.
Virus	On (Yellow)	The anti-virus function is enabled.
CSM	On	The profile of CSM (Content Security Management) for IM/P2P, URL content filter and/or Web content filter application is enabled from <b>Firewall &gt;&gt; General Setup</b> or <b>Filter Setup</b> . (Such profile is established under <b>CSM</b> menu).
WAN1/2	On	The WAN1 or WAN2 connection is ready.
	Blinking	It will blink while transmitting data.
MGMT	On	The router is managed by Telnet.
	Blinking	It will blink while being managed by IE browser.
Phone 1/2	On	The phone connected to this port is off-hook.
	Off	The phone connected to this port is on-hook.
	Blinking	A phone call comes.

### LED on Connector

ISDN S0 1	Left LED (Orange)	On	ISDN NT (ISDN S0 intern) mode is active and an ISDN phone adapter is connected.
		Blinking	ISDN NT (ISDN S0 intern) mode is active and an ISDN phone adapter is not connected.
	Right LED (Green)	On	A phone has been connected. If not, green LED will be off.
		Blinking	An ISDN phone is off-hook or a phone call comes.
ISDN S0 2	Left LED (Orange)	On	ISDN NT (ISDN S0 intern) mode is active configured from <b>VoIP&gt;&gt;Phone Settings</b> and an ISDN phone adapter is connected.
		Blinking	ISDN NT (ISDN S0 intern) mode configured from <b>VoIP&gt;&gt;Phone Settings</b> is active and an ISDN phone adapter is not connected.
		Off	It means ISDN TE mode is active which is configured from <b>VoIP&gt;&gt;Phone Settings</b> .
	Right LED (Green)	On	A phone adapter with phone set has been connected (ISDN S0 intern mode) or ISDN line has been connected (ISDN S0 extern mode). It will be off if there is nothing connected.
		Blinking	In ISDN NT (ISDN S0 intern) mode, it means an ISDN phone is off-hook or a phone call comes. In ISDN TE mode, it means data, fax or voice (phone call) is transmitting.
WAN 1/2	Left LED (Green)	On	The port is connected.
		Off	The port is disconnected.
		Blinking	The data is transmitting.



	Right LED (Green)	On	The port is connected with 100Mbps.
		Off	The port is connected with 10Mbps.
LAN 1/2/3/4	Left LED (Green)	On	The port is connected.
		Off	The port is disconnected.
		Blinking	The data is transmitting.
	Right LED (Green)	On	The port is connected with 100Mbps.
Off		The port is connected with 10Mbps.	



Interface	Description
Factory Reset	Restore the default settings. Usage: Turn on the router (ACT LED is blinking). Press the hole and keep for more than 5 seconds. When you see the ACT LED begins to blink rapidly than usual, release the button. Then the router will restart with the factory default configuration.
Restart	Restart the router forcefully.
Phone (1/2)	Connecters for PSTN phones.
ISDN S0 1	Connecter for ISDN phone(s) only via ISDN phone adapter. Do not connect any other device to such port or connect ISDN line, otherwise the router might be damaged.
ISDN S0 2	Connecter for ISDN line or ISDN phone adapter in particular condition. Refer to section 2.2 for more details.
WAN (1/2)	Connecters for remote networked devices.
LAN (1-4)	Connecters for local networked devices.
PWR	Connector for a power adapter.
ON/OFF	Power Switch.

## 1.1.5 For VigorPro5300VSn

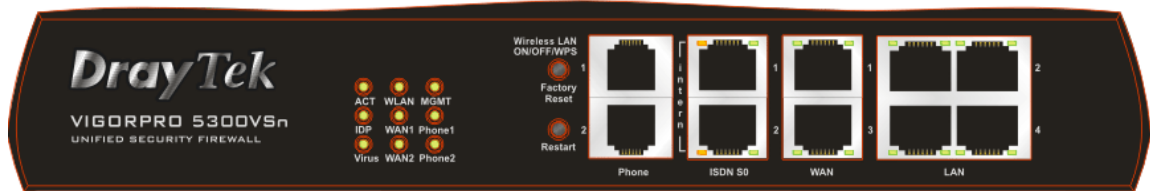

LED	Status	Explanation
ACT (Activity)	Blinking	The router is powered on and running normally.
	Off	The router is powered off.
IDP (Intrusion Detection and Prevention)	On (Yellow)	The anti-intrusion function is enabled.
Virus	On (Yellow)	The anti-virus function is enabled.
WLAN	On	Wireless access point is ready.
	Blinking	It will blink slowly while wireless traffic goes through. If ACT and WLAN LEDs blink quickly and simultaneously when WPS is working, and it will return to normal condition after two minutes. (You need to setup WPS within 2 minutes.)
WAN1/2	On	The WAN1 or WAN2 connection is ready.
	Blinking	It will blink while transmitting data.
MGMT	On	The router is managed by Telnet.
	Blinking	It will blink while being managed by IE browser.
Phone 1/2	On	The phone connected to this port is off-hook.
	Off	The phone connected to this port is on-hook.
	Blinking	A phone call comes.

### LED on Connector

ISDN S0 1	Left LED (Orange)	On	ISDN NT (ISDN S0 intern) mode is active and an ISDN phone adapter is connected.
		Blinking	ISDN NT (ISDN S0 intern) mode is active and an ISDN phone adapter is not connected.
	Right LED (Green)	On	A phone has been connected. If not, green LED will be off.
		Blinking	An ISDN phone is off-hook or a phone call comes.
ISDN S0 2	Left LED (Orange)	On	ISDN NT (ISDN S0 intern) mode is active configured from <b>VoIP&gt;&gt;Phone Settings</b> and an ISDN phone adapter is connected.
		Blinking	ISDN NT (ISDN S0 intern) mode configured from <b>VoIP&gt;&gt;Phone Settings</b> is active and an ISDN phone adapter is not connected.
		Off	It means ISDN TE mode is active which is configured from <b>VoIP&gt;&gt;Phone Settings</b> .
	Right LED (Green)	On	A phone adapter with phone set has been connected (ISDN S0 intern mode) or ISDN line has been connected (ISDN S0 extern mode). It will be off if there is nothing connected.
		Blinking	In ISDN NT (ISDN S0 intern) mode, it means an ISDN phone is off-hook or a phone call comes. In ISDN TE mode, it means data, fax or voice (phone call) is transmitting.
WAN 1/2	Left LED (Green)	On	The port is connected.
		Off	The port is disconnected.

		Blinking	The data is transmitting.
	Right LED (Green)	On	The port is connected with 100Mbps.
LAN 1/2/3/4	Left LED (Green)	Off	The port is connected with 10Mbps.
		On	The port is connected.
		Off	The port is disconnected.
	Right LED (Green)	Blinking	The data is transmitting.
		On	The port is connected with 100Mbps.
		Off	The port is connected with 10Mbps.

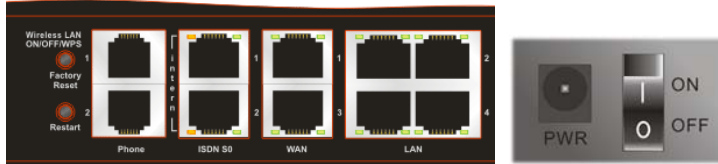

Interface	Description
Wireless LAN ON/OFF/WPS	Press "Wireless LAN ON/OFF/WPS" button for 2 seconds to wait for client device making network connection through WPS.
Factory Reset	Press "Wireless LAN ON/OFF/WPS" button once to enable (WLAN LED on) or disable (WLAN LED off) wireless connection.
Restart	Restore the default settings. Usage: Turn on the router (ACT LED is blinking). Press the hole and keep for more than 5 seconds. When you see the ACT LED begins to blink rapidly than usual, release the button. Then the router will restart with the factory default configuration.
Phone (1/2)	Restart the router forcefully.
ISDN S0 1	Connecters for PSTN phones.
ISDN S0 2	Connector for ISDN phone(s) only via ISDN phone adapter. Do not connect any other device to such port or connect ISDN line, otherwise the router might be damaged.
WAN (1/2)	Connector for ISDN line or ISDN phone adapter in particular condition. Refer to section 2.2 for more details.
LAN (1-4)	Connecters for remote networked devices.
PWR	Connecters for local networked devices.
ON/OFF	Connector for a power adapter.
	Power Switch.

## 1.3 Hardware Installation

Before starting to configure the router, you have to connect your devices correctly.

1. Connect a cable Modem/DSL Modem/Media Converter (depends on your requirement) to any WAN port of router with Ethernet cable (RJ-45). The **WAN1/WAN2 LED** (Right) will light up according to the network speed (100 or 10) of the device that it connected.
2. Connect one end of an Ethernet cable (RJ-45) to one of the **LAN** ports of the router and the other end of the cable (RJ-45) into the Ethernet port on your computer.
3. Connect the telephone sets with phone lines (for using VoIP function). For the model without phone ports, skip this step.
4. Connect one end of the power adapter to the router's power port on the rear panel, and the other side into a wall outlet.
5. Power on the device by pressing down the power switch on the rear panel.
6. The system starts to initiate. After completing the system test, the **ACT LED** will light up and start blinking.

(For the detailed information of LED status, please refer to section 1.1.)

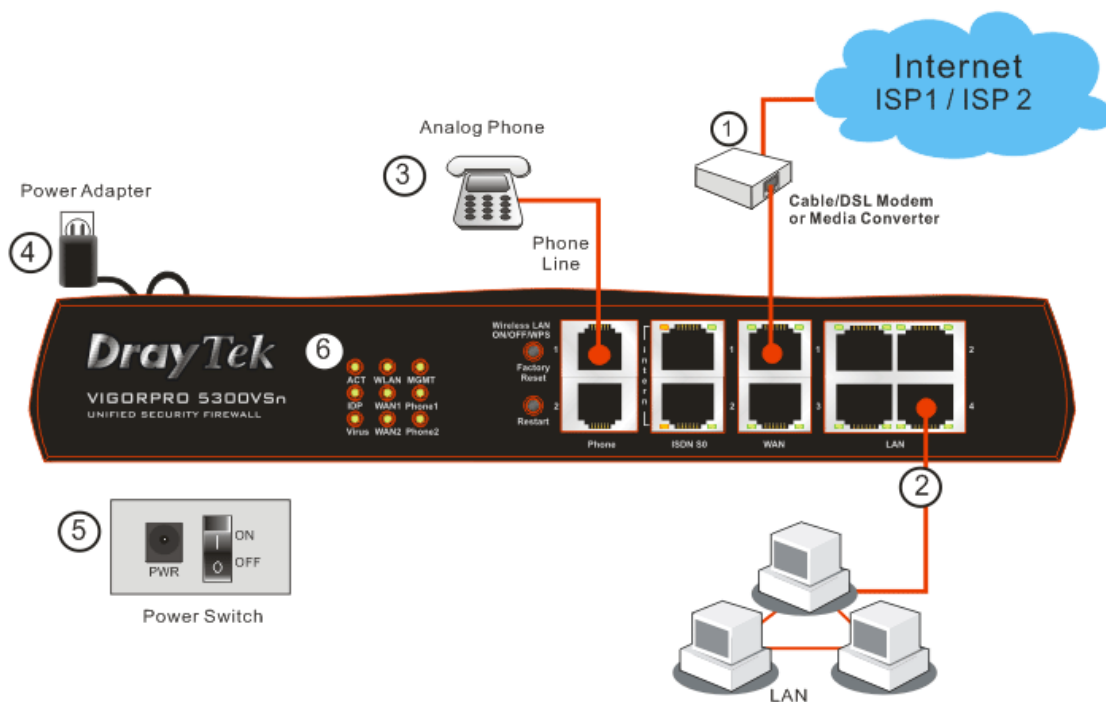

**Caution:** Each of the Phone ports can be connected to an analog phone only. Do not connect the phone ports to the telephone wall jack. Such connection might damage your router.

## 1.4 ISDN Phone Adapter Installation

Such information is provided for Vigor5300 S models (e.g., Vigor5300VS/VSn).

ISDN S0 1 is always fixed to connect ISDN phone. However, ISDN S0 2 is configurable as NT (ISDN S0 intern) or TE (ISDN S0 extern) mode. When the user configures ISDN S0 2 as

NT mode in **VoIP>> Phone Settings**, the **orange** LED will light on to indicate **ISDN2-S0** is selected. And by using ISDN phone adapters (coming from the router package), the user can connect several phones to Vigor5300VS for communication. Refer to the following figure for reference.

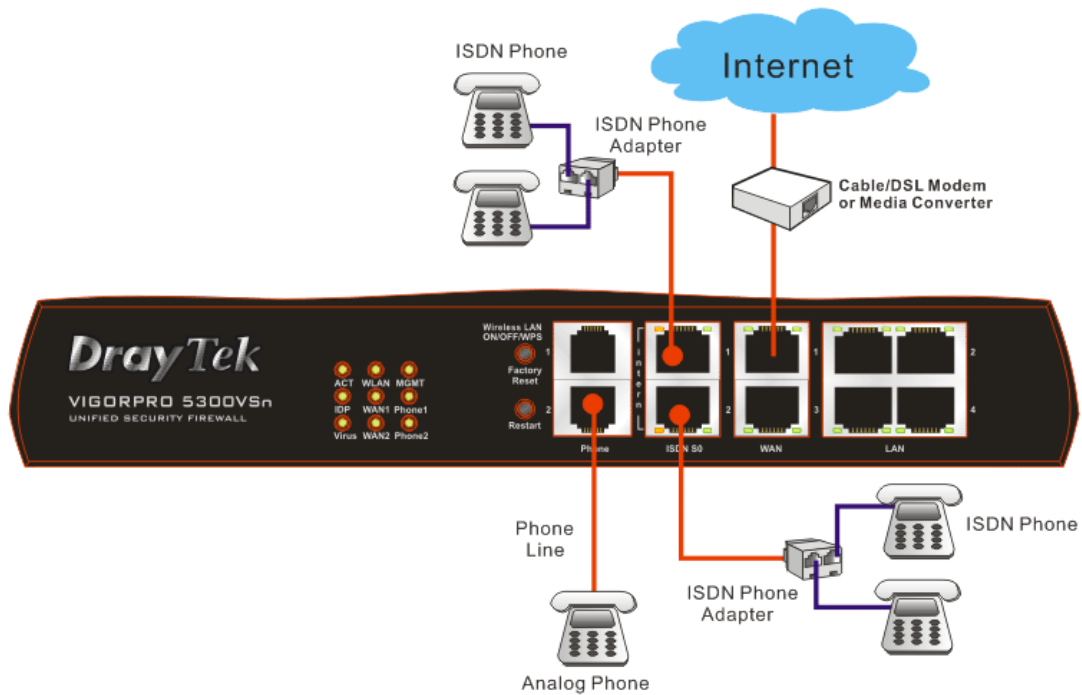

Yet, if the user configures ISDN S0 2 as TE Mode in **VoIP>> Phone Settings**, the **green** LED will light on to indicate **ISDN2-TE** is selected. Then, the port is specified for ISDN line only. Refer to the following figure for reference.

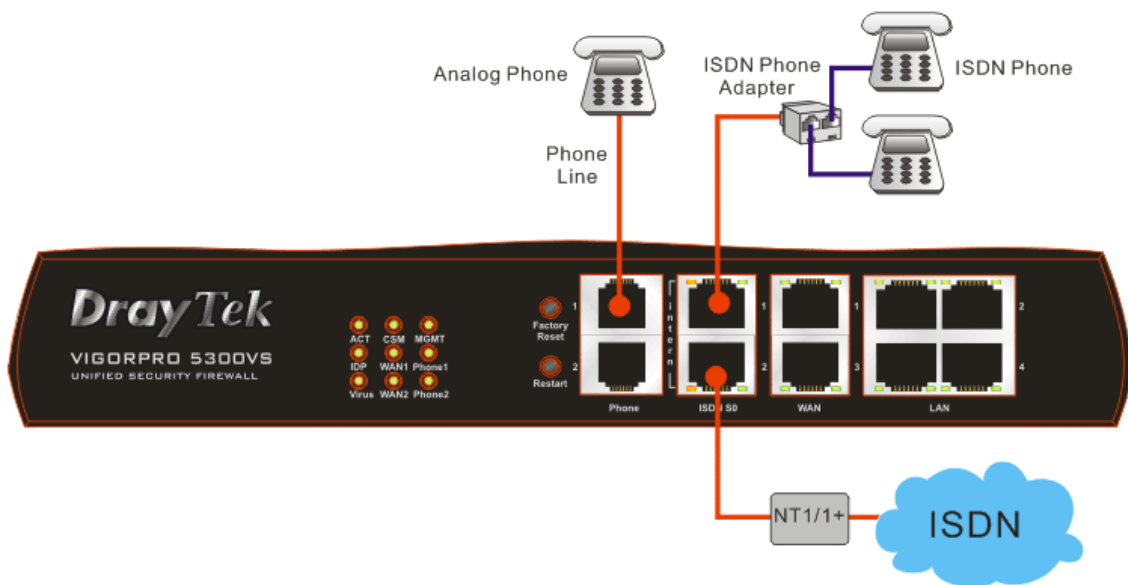

(For the detailed information of LED status, please refer to section 1.2.)



# 2

## Configuring Basic Settings

For use the router properly, it is necessary for you to change the password of web configuration for security and adjust primary basic settings.

This chapter explains how to setup a password for an administrator and how to adjust basic settings for accessing Internet successfully. Be aware that only the administrator can change the router configuration.

### 2.1 Changing Password

To change the password for this device, you have to access into the web browse with default password first.

1. Make sure your computer connects to the router correctly.



---

**Notice:** You may either simply set up your computer to get IP dynamically from the router or set up the IP address of the computer to be the same subnet as **the default IP address of Vigor router 192.168.1.1**. For the detailed information, please refer to the later section - Trouble Shooting of this guide.

---

2. Open a web browser on your PC and type **http://192.168.1.1**. A pop-up window will open to ask for username and password. Please type default values (both username and password are Null) on the window for the first time accessing and click **OK** for next screen.



- Now, the **Main Screen** will pop up.

**DrayTek VIGORPRO 5300 UNIFIED SECURITY FIREWALL**

**System Status**

Model Name : VigorPro5300 series  
 Firmware Version : 3.3.1\_RC1  
 Build Date/Time : Apr 11 2008 11:08:09  
 Signature Version : basic  
 Signature Build Date : Tue Aug 29 09:16:25.00 2006

LAN	
MAC Address	: 00-50-7F-22-33-44
1st IP Address	: 192.168.1.1
1st Subnet Mask	: 255.255.255.0
DHCP Server	: Yes
DNS	: 194.109.6.66

WAN 1	
Link Status	: Connected
MAC Address	: 00-50-7F-22-33-45
Connection	: Static IP
IP Address	: 172.16.3.229
Default Gateway	: 172.16.3.4
Mode	: NAT

VoIP			
Port	Profile	Reg.	In/Out
Phone1		No	0/0
Phone2		No	0/0
ISDN1-S0		No	0/0
ISDN2-TE		No	0/0

WAN 2	
Link Status	: Disconnected
MAC Address	: 00-50-7F-22-33-46
Connection	: ---
IP Address	: ---
Default Gateway	: ---
Mode	: NAT

Wireless LAN	
MAC Address	: 00-50-7f-22-33-44
Frequency Domain	: Europe
Firmware Version	: v1.04.11.09.7.5
SSID	: default

**Note:** The home page will change slightly in accordance with the router you have.

- Go to **System Maintenance** page and choose **Administrator Password**.

System Maintenance >> Administrator Password Setup

**Administrator Password**

Old Password	<input type="text"/>
New Password	<input type="text"/>
Confirm Password	<input type="text"/>

OK

- Enter the login password (the default is blank) on the field of **Old Password**. Type a new one in the field of **New Password** and retype it on the field of **Retype New Password**. Then click **OK** to continue.
- Now, the password has been changed. Next time, use the new password to access the Web Configurator for this router.



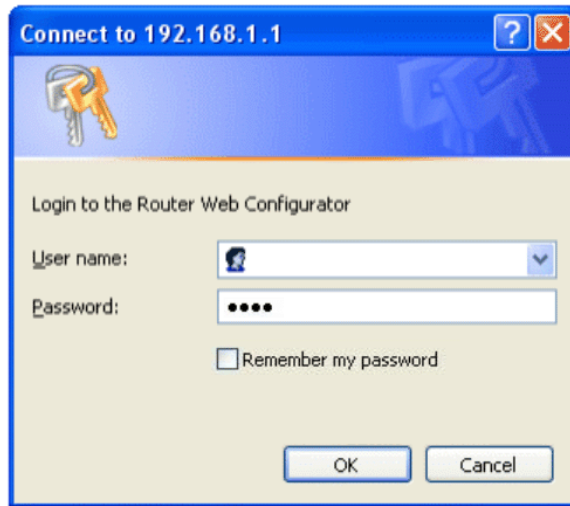

## 2.2 Quick Start Wizard

If your router can be under an environment with high speed NAT, the configuration provide here can help you to deploy and use the router quickly. The first screen of **Quick Start Wizard** is entering login password. After typing the password, please click **Next**.

### Quick Start Wizard

#### Enter login password

Please enter an alpha-numeric string as your **Password** (Max 23 characters).

New Password

Confirm Password

< Back   Next >   Finish   Cancel

On the next page as shown below, please select the WAN interface that you use. Choose **Auto negotiation** as the physical type for your router. Then click **Next** for next step.

## Quick Start Wizard

### Select WAN Interface

Select WAN Interface:	WAN1 ▾
Display Name:	<input type="text"/>
Physical Mode:	Ethernet
Physical Type:	Auto negotiation ▾

On the next page as shown below, please select the appropriate Internet access type according to the information from your ISP. For example, you should select PPPoE mode if the ISP provides you PPPoE interface. Then click **Next** for next step.

## Quick Start Wizard

### Connect to Internet

**WAN 1**  
Select one of the following Internet Access types provided by your ISP.

- PPPoE
- PPTP
- Static IP
- DHCP

In the **Quick Start Wizard**, you can configure the router to access the Internet with different protocol/modes such as **PPPoE**, **PPTP**, **Static IP** or **DHCP**. The router supports the DSL WAN interface for Internet access.

## 2.2.1 PPPoE

PPPoE stands for **Point-to-Point Protocol over Ethernet**. It relies on two widely accepted standards: PPP and Ethernet. It connects users through an Ethernet to the Internet with a common broadband medium, such as a single DSL line, wireless device or cable modem. All the users over the Ethernet can share a common connection.

PPPoE is used for most of DSL modem users. All local users can share one PPPoE connection for accessing the Internet. Your service provider will provide you information about user name, password, and authentication mode.

If your ISP provides you the **PPPoE** connection, please select **PPPoE** for this router. The following page will be shown.

Quick Start Wizard

**PPPoE Client Mode**

**WAN 1**  
Enter the user name and password provided by your ISP.

User Name	<input type="text" value="admin"/>
Password	<input type="password" value="••••"/>
Confirm Password	<input type="password" value="••••"/>

**User Name** Assign a specific valid user name provided by the ISP.

**Password** Assign a valid password provided by the ISP.

**Confirm Password** Retype the password for confirmation.

Click **Next** for viewing summary of such connection.

Quick Start Wizard

**Please confirm your settings:**

WAN Interface:	WAN1
Physical Mode:	Ethernet
Physical Type:	Auto negotiation
Internet Access:	PPPoE

Click **Back** to modify changes if necessary. Otherwise, click **Finish** to save the current settings and restart the Vigor router.

Click **Finish**. A page of **Quick Start Wizard Setup OK!!!** will appear. Then, the system status of this protocol will be shown.

**Quick Start Wizard Setup OK !!!**

## 2.2.2 PPTP

Click **PPTP** as the protocol. Type in all the information that your ISP provides for this protocol.

### Quick Start Wizard

---

#### PPTP Client Mode

<b>WAN 1</b>	
Enter the user name, password, WAN IP configuration and PPTP server IP provided by your ISP.	
User Name	<input type="text" value="admin"/>
Password	<input type="password" value="••••"/>
Confirm Password	<input type="password" value="••••"/>
WAN IP Configuration	
<input type="radio"/> Obtain an IP address automatically	
<input checked="" type="radio"/> Specify an IP address	
IP Address	<input type="text" value="172.16.3.229"/>
Subnet Mask	<input type="text" value="255.255.0.0"/>
PPTP Server IP	<input type="text"/>

Click **Next** for viewing summary of such connection.

### Quick Start Wizard

---

#### Please confirm your settings:

WAN Interface:	WAN1
Physical Mode:	Ethernet
Physical Type:	Auto negotiation
Internet Access:	PPTP

Click **Back** to modify changes if necessary. Otherwise, click **Finish** to save the current settings and restart the Vigor router.

Click **Finish**. A page of **Quick Start Wizard Setup OK!!!** will appear. Then, the system status of this protocol will be shown.

**Quick Start Wizard Setup OK !!!**

## 2.2.3 Static IP

Click **Static IP** as the protocol. Type in all the information that your ISP provides for this protocol.

### Quick Start Wizard

---

#### Static IP Client Mode

<b>WAN 1</b>	
Enter the Static IP configuration provided by your ISP.	
WAN IP	<input type="text" value="172.16.3.229"/>
Subnet Mask	<input type="text" value="255.255.0.0"/>
Gateway	<input type="text" value="172.16.1.1"/>
Primary DNS	<input type="text" value="168.95.1.1"/>
Secondary DNS	<input type="text"/> (optional)

After finishing the settings in this page, click **Next** to see the following page.

### Quick Start Wizard

---

#### Please confirm your settings:

WAN Interface:	WAN1
Physical Mode:	Ethernet
Physical Type:	Auto negotiation
Internet Access:	Static IP

Click **Back** to modify changes if necessary. Otherwise, click **Finish** to save the current settings and restart the Vigor router.

Click **Finish**. A page of **Quick Start Wizard Setup OK!!!** will appear. Then, the system status of this protocol will be shown.

**Quick Start Wizard Setup OK !!!**

## 2.2.4 DHCP

Click **DHCP** as the protocol. Type in all the information that your ISP provides for this protocol.

### Quick Start Wizard

---

#### DHCP Client Mode

##### WAN 1

If your ISP requires you to enter a specific host name or specific MAC address, please enter it in.

Host Name  (optional)

MAC       (optional)

< Back

Next >

Finish

Cancel

After finishing the settings in this page, click **Next** to see the following page.

### Quick Start Wizard

---

#### Please confirm your settings:

WAN Interface: WAN1  
Physical Mode: Ethernet  
Physical Type: Auto negotiation  
Internet Access: DHCP

Click **Back** to modify changes if necessary. Otherwise, click **Finish** to save the current settings and restart the Vigor router.

< Back

Next >

Finish

Cancel

Click **Finish**. A page of **Quick Start Wizard Setup OK!!!** will appear. Then, the system status of this protocol will be shown.

**Quick Start Wizard Setup OK !!!**

## 2.3 Online Status

The online status shows the system status, WAN status, ADSL Information and other status related to this router within one page. If you select **PPPoE/PPTP** as the protocol, you will find out a link of **Dial PPPoE/PPPoA** or **Drop PPPoE/PPPoA** in the Online Status web page.

### Online status for PPPoE (WAN2)

System Status				System Uptime: 0:0:18		
LAN Status		Primary DNS: 168.95.192.1		Secondary DNS: 168.95.1.1		
IP Address		TX Packets	RX Packets			
192.168.1.1		77	56			
WAN 1 Status						
Enable	Line	Name	Mode	Up Time		
Yes	Ethernet		Static IP	0:00:11		
IP	GW IP	TX Packets	TX Rate	RX Packets	RX Rate	
192.168.5.100	192.168.5.1	3	17	3	42	
WAN 2 Status						>> <a href="#">Drop PPPoE</a>
Enable	Line	Name	Mode	Up Time		
Yes	Ethernet		PPPoE	0:00:11		
IP	GW IP	TX Packets	TX Rate	RX Packets	RX Rate	
61.230.209.207	61.230.192.254	10	16	10	12	

### Online status for PPTP (for WAN2)

System Status				System Uptime: 0:0:18		
LAN Status		Primary DNS: 168.95.192.1		Secondary DNS: 168.95.1.1		
IP Address		TX Packets	RX Packets			
192.168.1.1		77	56			
WAN 1 Status						
Enable	Line	Name	Mode	Up Time		
Yes	Ethernet		Static IP	0:00:11		
IP	GW IP	TX Packets	TX Rate	RX Packets	RX Rate	
192.168.5.100	192.168.5.1	3	17	3	42	
WAN 2 Status						>> <a href="#">Drop PPPoE</a>
Enable	Line	Name	Mode	Up Time		
Yes	Ethernet	WAN2	PPTP	0:00:15		
IP	GW IP	TX Packets	TX Rate	RX Packets	RX Rate	
192.168.29.202	192.168.29.1	103	119	14	6	

### Online status for Static IP (for WAN1)

System Status				System Uptime: 0:0:18		
LAN Status		Primary DNS: 168.95.192.1		Secondary DNS: 168.95.1.1		
IP Address		TX Packets	RX Packets			
192.168.1.1		77	56			
WAN 1 Status						
Enable	Line	Name	Mode	Up Time		
Yes	Ethernet		Static IP	0:00:11		
IP	GW IP	TX Packets	TX Rate	RX Packets	RX Rate	
192.168.5.100	192.168.5.1	3	17	3	42	
WAN 2 Status						>> <a href="#">Drop PPPoE</a>
Enable	Line	Name	Mode	Up Time		
Yes	Ethernet		PPPoE	0:00:11		
IP	GW IP	TX Packets	TX Rate	RX Packets	RX Rate	
61.230.209.207	61.230.192.254	10	16	10	12	

## Online status for DHCP

System Status			System Uptime: 0:6:52		
<b>LAN Status</b>		Primary DNS: 168.95.192.1		Secondary DNS: 168.95.1.1	
<b>IP Address</b>	<b>TX Packets</b>	<b>RX Packets</b>			
192.168.1.1	677	558			
<b>WAN 1 Status</b>					>> <a href="#">Release</a>
<b>Enable</b>	<b>Line</b>	<b>Name</b>	<b>Mode</b>	<b>Up Time</b>	
Yes	Ethernet		DHCP Client	0:06:45	
<b>IP</b>	<b>GW IP</b>	<b>TX Packets</b>	<b>TX Rate</b>	<b>RX Packets</b>	<b>RX Rate</b>
192.168.5.10	192.168.5.1	89	3	68	3
<b>WAN 2 Status</b>					>> <a href="#">Drop PPPoE</a>
<b>Enable</b>	<b>Line</b>	<b>Name</b>	<b>Mode</b>	<b>Up Time</b>	
Yes	Ethernet		PPPoE	0:01:34	
<b>IP</b>	<b>GW IP</b>	<b>TX Packets</b>	<b>TX Rate</b>	<b>RX Packets</b>	<b>RX Rate</b>
61.230.213.66	61.230.192.254	21	7	45	13

Detailed explanation is shown below:

<b>Primary DNS</b>	Displays the IP address of the primary DNS.
<b>Secondary DNS</b>	Displays the IP address of the secondary DNS.
<b>LAN Status</b>	
<b>IP Address</b>	Displays the IP address of the LAN interface.
<b>TX Packets</b>	Displays the total transmitted packets at the LAN interface.
<b>RX Packets</b>	Displays the total number of received packets at the LAN interface.
<b>WAN1/2 Status</b>	
<b>Line</b>	Displays the physical connection (Ethernet) of this interface.
<b>Name</b>	Displays the name set in WAN1/WAN web page.
<b>Mode</b>	Displays the type of WAN connection (e.g., PPPoE).
<b>Up Time</b>	Displays the total uptime of the interface.
<b>IP</b>	Displays the IP address of the WAN interface.
<b>GW IP</b>	Displays the IP address of the default gateway.
<b>TX Packets</b>	Displays the total transmitted packets at the WAN interface.
<b>TX Rate</b>	Displays the speed of transmitted octets at the WAN interface.
<b>RX Packets</b>	Displays the total number of received packets at the WAN interface.
<b>RX Rate</b>	Displays the speed of received octets at the WAN interface.

**Note:** The words in green mean that the WAN connection of that interface (WAN1/WAN2) is ready for accessing Internet; the words in red mean that the WAN connection of that interface (WAN1/WAN2) is not ready for accessing Internet.



## 2.4 Saving Configuration

Each time you click **OK** on the web page for saving the configuration, you can find messages showing the system interaction with you.



**Status: Ready**

**Ready** indicates the system is ready for you to input settings.

**Settings Saved** means your settings are saved once you click **Finish** or **OK** button.

This page is left blank.

# 3

## Advanced Web Configuration

After finished basic configuration of the router, you can access Internet with ease. For the people who want to adjust more setting for suiting his/her request, please refer to this chapter for getting detailed information about the advanced configuration of this router. As for other examples of application, please refer to chapter 4.

### 3.1 WAN

**Quick Start Wizard** offers user an easy method to quick setup the connection mode for the router. Moreover, if you want to adjust more settings for different WAN modes, please go to **WAN** group and click the **Internet Access** link.

#### 3.1.1 Basics of Internet Protocol (IP) Network

IP means Internet Protocol. Every device in an IP-based Network including routers, print server, and host PCs, needs an IP address to identify its location on the network. To avoid address conflicts, IP addresses are publicly registered with the Network Information Centre (NIC). Having a unique IP address is mandatory for those devices participated in the public network but not in the private TCP/IP local area networks (LANs), such as host PCs under the management of a router since they do not need to be accessed by the public. Hence, the NIC has reserved certain addresses that will never be registered publicly. These are known as *private* IP addresses, and are listed in the following ranges:

**From 10.0.0.0 to 10.255.255.255**

**From 172.16.0.0 to 172.31.255.255**

**From 192.168.0.0 to 192.168.255.255**

#### What are Public IP Address and Private IP Address

As the router plays a role to manage and further protect its LAN, it interconnects groups of host PCs. Each of them has a private IP address assigned by the built-in DHCP server of the Vigor router. The router itself will also use the default **private IP** address: 192.168.1.1 to communicate with the local hosts. Meanwhile, Vigor router will communicate with other network devices through a **public IP** address. When the data flow passing through, the Network Address Translation (NAT) function of the router will dedicate to translate public/private addresses, and the packets will be delivered to the correct host PC in the local area network. Thus, all the host PCs can share a common Internet connection.

#### Get Your Public IP Address from ISP

In ADSL deployment, the PPP (Point to Point)-style authentication and authorization is required for bridging customer premises equipment (CPE). Point to Point Protocol over Ethernet (PPPoE) connects a network of hosts via an access device to a remote access concentrator or aggregation concentrator. This implementation provides users with significant ease of use. Meanwhile it provides access control, billing, and type of service according to user requirement.

When a router begins to connect to your ISP, a serial of discovery process will occur to ask for a connection. Then a session will be created. Your user ID and password is authenticated via **PAP** or **CHAP** with **RADIUS** authentication system. And your IP address, DNS server, and other related information will usually be assigned by your ISP.

Below shows the menu items for WAN.

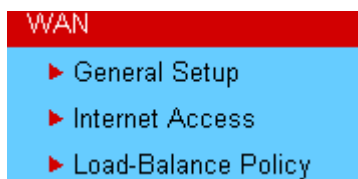

### 3.1.2 General Setup

This section will introduce some general settings of Internet and explain the connection modes for WAN1 and WAN2 in details.

This router supports dual WAN function. It allows users to access Internet and combine the bandwidth of the dual WAN to speed up the transmission through the network. Each WAN port can connect to different ISPs, Even if the ISPs use different technology to provide telecommunication service (such as DSL, Cable modem, etc.). If any connection problem occurred on one of the ISP connections, all the traffic will be guided and switched to the normal communication port for proper operation. Please configure WAN1 and WAN2 settings.

This webpage allows you to set general setup for WAN1 and WAN2 respectively.

**Note:** In default, WAN1 and WAN2 are enabled.

WAN >> General Setup

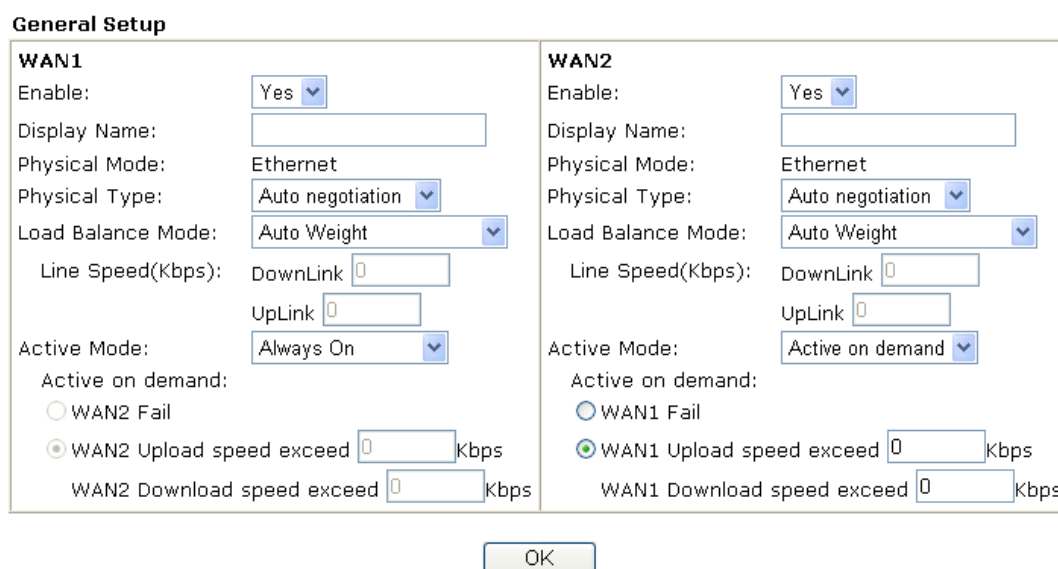

The screenshot shows the 'General Setup' page for WAN1 and WAN2. Each interface has the following settings:

- Enable:** Yes (dropdown)
- Display Name:** (text input)
- Physical Mode:** Ethernet
- Physical Type:** Auto negotiation (dropdown)
- Load Balance Mode:** Auto Weight (dropdown)
- Line Speed(Kbps):** DownLink (text input), UpLink (text input)
- Active Mode:** Always On (dropdown)
- Active on demand:** Radio buttons for WAN2 Fail, WAN1 Fail, WAN1 Upload speed exceed (selected), and WAN1 Download speed exceed.
- Speed Exceed:** Text inputs for upload and download speeds in Kbps.

An 'OK' button is located at the bottom center of the configuration area.

- Enable** Choose **Yes** to invoke the settings for this WAN interface. Choose **No** to disable the settings for this WAN interface.
- Display Name** Type the description for the WAN1/WAN2 interface.
- Physical Mode** For WAN1, the physical connection is done through ADSL port; yet the physical connection for WAN2 is done through an Ethernet port (P1). You cannot change it.

## Physical Type

You can change the physical type for WAN2 or choose **Auto negotiation** for determined by the system.

Physical Type: 

The dropdown menu shows the following options: Auto negotiation (selected), 10M half duplex, 10M full duplex, 100M half duplex, and 100M full duplex.

## Load Balance Mode

If you know the practical bandwidth for your WAN interface, please choose the setting of **According to Line Speed**. Otherwise, please choose **Auto Weigh** to let the router reach the best load balance.

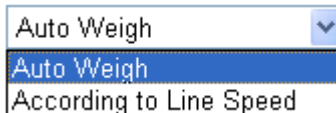
Load Balance Mode: 

The dropdown menu shows the following options: Auto Weigh (selected) and According to Line Speed.

## Line Speed

If your choose **According to Line Speed** as the **Load Balance Mode**, please type the line speed for downloading and uploading through WAN1/WAN2. The unit is kbps.

## Active Mode

Choose **Always On** to make the WAN connection (WAN1/WAN2) being activated always; or choose **Active on demand** to make the WAN connection (WAN1/WAN2) activated if it is necessary.

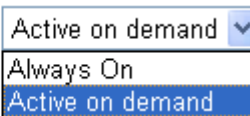
Active Mode: 

The dropdown menu shows the following options: Active on demand (selected), Always On, and Active on demand.

If you choose Active on demand, the Idle Timeout will be available for you to set for PPPoE and PPTP access modes in the Details Page of WAN>>Internet Access. In addition, there are three selections for you to choose for different purposes.

**WAN2 Fail** – It means the connection for WAN1 will be activated when WAN2 is failed.

**WAN2 Upload speed exceed XX kbps** – It means the connection for WAN1 will be activated when WAN2 Upload speed exceed certain value that you set in this box for 15 seconds.

**WAN2 Download speed exceed XX kbps**– It means the connection for WAN1 will be activated when WAN2 Download speed exceed certain value that you set in this box for 15 seconds.

**WAN1 Fail** – It means the connection for WAN2 will be activated when WAN1 is failed.

**WAN1 Upload speed exceed XX kbps** – It means the connection for WAN2 will be activated when WAN1 Upload speed exceed certain value that you set in this box for 15 seconds.

**WAN1 Download speed exceed XX kbps**– It means the connection for WAN2 will be activated when WAN1 Download speed exceed certain value that you set in this box for 15 seconds.

### 3.1.3 Internet Access

For the router supports dual WAN function, the users can set different WAN settings (for WAN1/WAN2) for Internet Access. Due to different physical mode for WAN1 and WAN2, the Access Mode for these two connections also varies slightly.

WAN >> Internet Access

Internet Access				
Index	Display Name	Physical Mode	Access Mode	
WAN1		Ethernet	Static or Dynamic IP	<a href="#">Details Page</a>
WAN2		Ethernet	None	<a href="#">Details Page</a>

#### Index

It shows the WAN modes that this router supports. WAN1 is the default WAN interface for accessing into the Internet. WAN2 is the optional WAN interface for accessing into the Internet when WAN 1 is inactive for some reason.

#### Display Name

It shows the name of the WAN1/WAN2 that entered in general setup.

#### Physical Mode

It shows the physical port for WAN1/WAN2.

#### Access Mode

Use the drop down list to choose a proper access mode. The details page of that mode will be popped up. If not, click Details Page for accessing the page to configure the settings.

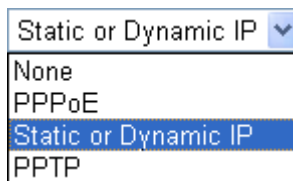

There are three access modes provided for PPPoE, Static or Dynamic IP and PPTP.

#### Details Page

This button will open different web page according to the access mode that you choose in WAN1 or WAN2.

## Details Page for PPPoE

To use **PPPoE** as the accessing protocol of the internet, please choose **Internet Access** from **WAN** menu. Then, select **PPPoE** mode for WAN2. The following web page will be shown.

WAN >> Internet Access

WAN 1

<p><b>PPPoE Client Mode</b></p> <p><input checked="" type="radio"/> Enable <input type="radio"/> Disable</p> <hr/> <p><b>ISP Access Setup</b></p> <p>Username <input type="text" value="admin"/></p> <p>Password <input type="password" value="•••••"/></p> <p>Index(1-15) in <b>Schedule</b> Setup: =&gt; <input type="text"/> , <input type="text"/> , <input type="text"/> , <input type="text"/></p> <p><b>ISDN Dial Backup Setup</b></p> <p>Dial Backup Mode <input type="text" value="None"/></p> <hr/> <p><b>WAN Connection Detection</b></p> <p>Mode <input type="text" value="ARP Detect"/></p> <p>Ping IP <input type="text"/></p> <p>TTL: <input type="text"/></p>	<p><b>PPP/MP Setup</b></p> <p>PPP Authentication <input type="text" value="PAP or CHAP"/></p> <p>Idle Timeout <input type="text" value="-1"/> second(s)</p> <p><b>IP Address Assignment Method (IPCP)</b> <input type="text" value="WAN IP Alias"/></p> <p>Fixed IP: <input type="radio"/> Yes <input checked="" type="radio"/> No (Dynamic IP)</p> <p>Fixed IP Address <input type="text"/></p> <hr/> <p><input checked="" type="radio"/> Default MAC Address <input type="radio"/> Specify a MAC Address</p> <p>MAC Address: <input type="text" value="00"/> <input type="text" value=".50"/> <input type="text" value=".7F"/> <input type="text" value=".22"/> <input type="text" value=".33"/> <input type="text" value=".45"/></p>
---	---

### PPPoE Client Mode

Click **Enable** for activating this function. If you click **Disable**, this function will be closed and all the settings that you adjusted in this page will be invalid.

### ISP Access Setup

Enter your allocated username, password and authentication parameters according to the information provided by your ISP. If you want to connect to Internet all the time, you can check **Always On**.

**Username** – Type in the username provided by ISP in this field.

**Password** – Type in the password provided by ISP in this field.

**Index (1-15) in Schedule Setup** - You can type in four sets of time schedule for your request. All the schedules can be set previously in **Application – Schedule** web page and you can use the number that you have set in that web page.

### ISDN Dial Backup Setup

This setting is available for the routers supporting ISDN function only. Before utilizing the ISDN dial backup feature, you must create a dial backup profile first.

**None** - Disable the backup function.

**Packet Trigger** -The backup line is not on until a packet from a local host triggers the router to establish a connection.

This setting is available for *i* model only.

Dial Backup Mode

### WAN Connection Detection

Such function allows you to verify whether network connection is alive or not through ARP Detect or Ping Detect.

**Mode** – Choose **ARP Detect** or **Ping Detect** for the system to execute for WAN detection.

**Ping IP** – If you choose Ping Detect as detection mode, you have to type IP address in this field for pinging.

**TTL (Time to Live)** – Displays value for your reference. TTL value is set by telnet command.

### PPP/MP Setup

**PPP Authentication** – Select **PAP only** or **PAP or CHAP** for PPP.

**Idle Timeout** – Set the timeout for breaking down the Internet after passing through the time without any action. This setting is active only when the **Active on demand** option for Active Mode is selected in **WAN>> General Setup** page.

### IP Address Assignment Method (IPCP)

Usually ISP dynamically assigns IP address to you each time you connect to it and request. In some case, your ISP provides service to always assign you the same IP address whenever you request. In this case, you can fill in this IP address in the Fixed IP field. Please contact your ISP before you want to use this function.

**WAN IP Alias** - If you have multiple public IP addresses and would like to utilize them on the WAN interface, please use WAN IP Alias. You can set up to 8 public IP addresses other than the current one you are using.

Index	Enable	Aux. WAN IP	Join NAT IP Pool
1.	<input checked="" type="checkbox"/>	172.16.3.229	<input checked="" type="checkbox"/>
2.	<input type="checkbox"/>	<input type="text"/>	<input type="checkbox"/>
3.	<input type="checkbox"/>	<input type="text"/>	<input type="checkbox"/>
4.	<input type="checkbox"/>	<input type="text"/>	<input type="checkbox"/>
5.	<input type="checkbox"/>	<input type="text"/>	<input type="checkbox"/>
6.	<input type="checkbox"/>	<input type="text"/>	<input type="checkbox"/>
7.	<input type="checkbox"/>	<input type="text"/>	<input type="checkbox"/>
8.	<input type="checkbox"/>	<input type="text"/>	<input type="checkbox"/>

OK Clear All Close

**Fixed IP** – Click **Yes** to use this function and type in a fixed IP address in the box of **Fixed IP Address**.

**Default MAC Address** – You can use **Default MAC Address** or specify another MAC address by typing on the boxes of MAC Address for the router.

**Specify a MAC Address** – Type the MAC address for the router manually.

After finishing all the settings here, please click **OK** to activate them.

### Details Page for Static or Dynamic IP



For static IP mode, you usually receive a fixed public IP address or a public subnet, namely multiple public IP addresses from your DSL or Cable ISP service providers. In most cases, a Cable service provider will offer a fixed public IP, while a DSL service provider will offer a public subnet. If you have a public subnet, you could assign an IP address or many IP address to the WAN interface.

To use **Static or Dynamic IP** as the accessing protocol of the internet, please choose **Internet Access** from **WAN** menu. Then, select **Static or Dynamic IP** mode for WAN2. The following web page will be shown.

WAN >> Internet Access

---

**WAN 1**

<p><b>Static or Dynamic IP (DHCP Client)</b></p> <p><input checked="" type="radio"/> Enable <input type="radio"/> Disable</p> <hr/> <p><b>ISDN Dial Backup Setup</b></p> <p>Dial Backup Mode <input type="text" value="None"/></p> <hr/> <p><b>Keep WAN Connection</b></p> <p><input type="checkbox"/> Enable PING to keep alive</p> <p>PING to the IP <input type="text" value=""/></p> <p>PING Interval <input type="text" value="0"/> minute(s)</p> <hr/> <p><b>WAN Connection Detection</b></p> <p>Mode <input type="text" value="ARP Detect"/></p> <p>Ping IP <input type="text" value="0.0.0.0"/></p> <p>TTL: 255</p> <hr/> <p><b>RIP Protocol</b></p> <p><input type="checkbox"/> Enable RIP</p>	<p><b>WAN IP Network Settings</b> <input type="button" value="WAN IP Alias"/></p> <p><input type="radio"/> Obtain an IP address automatically</p> <p>Router Name <input type="text" value=""/> *</p> <p>Domain Name <input type="text" value=""/> *</p> <p>* : Required for some ISPs</p> <p><input checked="" type="radio"/> Specify an IP address</p> <p>IP Address <input type="text" value="172.16.3.229"/></p> <p>Subnet Mask <input type="text" value="255.255.0.0"/></p> <p>Gateway IP Address <input type="text" value="172.16.3.4"/></p> <hr/> <p><input checked="" type="radio"/> Default MAC Address</p> <p><input type="radio"/> Specify a MAC Address</p> <p>MAC Address:</p> <p><input type="text" value="00"/> <input type="text" value="50"/> <input type="text" value="7F"/> <input type="text" value="22"/> <input type="text" value="33"/> <input type="text" value="45"/></p> <hr/> <p><b>DNS Server IP Address</b></p> <p>Primary IP Address <input type="text" value=""/></p> <p>Secondary IP Address <input type="text" value=""/></p>
---	---

**Static or Dynamic IP (DHCP Client)**

Click **Enable** for activating this function. If you click **Disable**, this function will be closed and all the settings that you adjusted in this page will be invalid.

**ISDN Dial Backup Setup**

This setting is available for the routers supporting ISDN function only. Before utilizing the ISDN dial backup feature, you must create a dial backup profile first.

**None** - Disable the backup function.

**Packet Trigger** -The backup line is not on until a packet from a local host triggers the router to establish a connection.

This setting is available for *i* model only.

**ISDN Dial Backup Setup**

Dial Backup Mode

None

Packet Trigger

Always On

**Keep WAN Connection**

Normally, this function is designed for Dynamic IP environments because some ISPs will drop connections if there is no traffic within certain periods of time. Check **Enable PING to keep alive** box to activate this function.

**PING to the IP** - If you enable the PING function, please specify the IP address for the system to PING it for keeping alive.

**PING Interval** - Enter the interval for the system to execute the PING operation.

**WAN Connection Detection**

Such function allows you to verify whether network connection is alive or not through ARP Detect or Ping Detect.

**Mode** – Choose **ARP Detect** or **Ping Detect** for the system to execute for WAN detection.

**Ping IP** – If you choose Ping Detect as detection mode, you have to type IP address in this field for pinging.

**TTL (Time to Live)** – Displays value for your reference. TTL value is set by telnet command.

**RIP Protocol**

Routing Information Protocol is abbreviated as RIP(RFC1058) specifying how routers exchange routing tables information. Click **Enable RIP** for activating this function.

**WAN IP Network Settings**

This group allows you to obtain an IP address automatically and allows you type in IP address manually.

**WAN IP Alias** - If you have multiple public IP addresses and would like to utilize them on the WAN interface, please use WAN IP Alias. You can set up to 8 public IP addresses other than the current one you are using. Notice that this setting is available for WAN1 only.

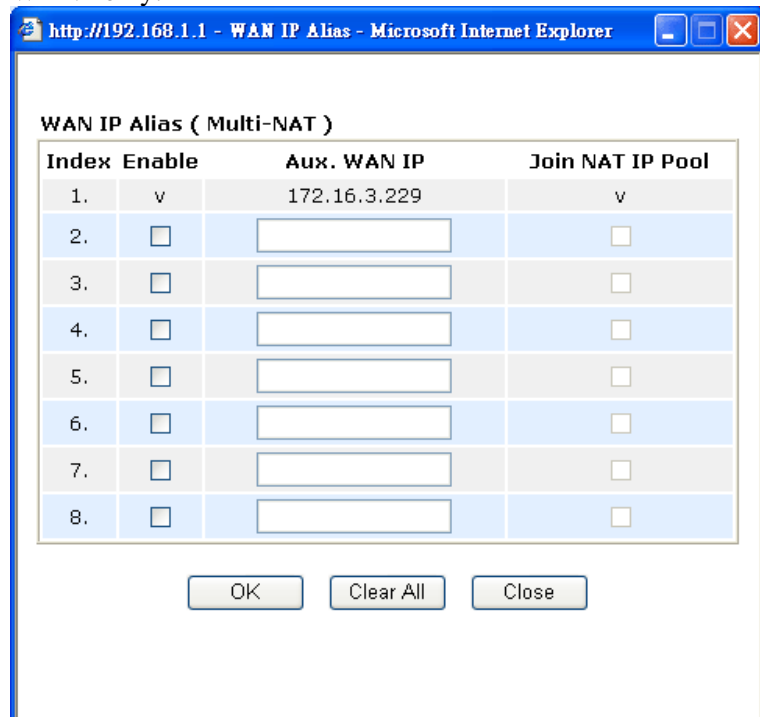

**Obtain an IP address automatically** – Click this button to obtain the IP address automatically if you want to use **Dynamic IP** mode.

**Router Name**: Type in the router name provided by ISP.

**Domain Name**: Type in the domain name that you have assigned.

**Specify an IP address** – Click this radio button to specify some data if you want to use **Static IP** mode.

**IP Address**: Type the IP address.

**Subnet Mask**: Type the subnet mask.

**Gateway IP Address**: Type the gateway IP address.

**Default MAC Address**: Click this radio button to use default MAC address for the router.

**Specify a MAC Address:** Some Cable service providers specify a specific MAC address for access authentication. In such cases you need to click the **Specify a MAC Address** and enter the MAC address in the MAC Address field.

**DNS Server IP Address**

Type in the primary IP address for the router if you want to use **Static IP** mode. If necessary, type in secondary IP address for necessity in the future.

**Details Page for PPTP**

To use **PPTP** as the accessing protocol of the internet, please choose **Internet Access** from **WAN** menu. Then, select **PPTP** mode for WAN2. The following web page will be shown.

WAN >> Internet Access

WAN 1

<p><b>PPTP Client Mode</b></p> <p><input type="radio"/> Enable <input checked="" type="radio"/> Disable</p> <p>PPTP Server <input type="text"/></p> <hr/> <p><b>ISP Access Setup</b></p> <p>Username <input type="text"/></p> <p>Password <input type="text"/></p> <p>Index(1-15) in <b>Schedule</b> Setup: =&gt; <input type="text"/>, <input type="text"/>, <input type="text"/>, <input type="text"/></p> <p><b>ISDN Dial Backup Setup</b></p> <p>Dial Backup Mode <input type="text" value="None"/> <ul style="list-style-type: none"> <li>None</li> <li>Packet Trigger</li> </ul> </p>	<p><b>PPP Setup</b></p> <p>PPP Authentication <input type="text" value="PAP or CHAP"/></p> <p>Idle Timeout <input type="text" value="-1"/> second(s)</p> <p><b>IP Address Assignment Method (IPCP)</b> <input type="text" value="WAN IP Alias"/></p> <p>Fixed IP: <input type="radio"/> Yes <input checked="" type="radio"/> No (Dynamic IP)</p> <p>Fixed IP Address <input type="text"/></p> <p><b>WAN IP Network Settings</b></p> <p><input type="radio"/> Obtain an IP address automatically</p> <p><input checked="" type="radio"/> Specify an IP address</p> <p>IP Address <input type="text" value="172.16.3.229"/></p> <p>Subnet Mask <input type="text" value="255.255.0.0"/></p>
---	---

**PPTP Setup**

**PPTP Link** - Click **Enable** to enable a PPTP client to establish a tunnel to a DSL modem on the WAN interface.

**PPTP Server** - Specify the IP address of the PPTP server.

**ISP Access Setup**

**Username** -Type in the username provided by ISP in this field.

**Password** -Type in the password provided by ISP in this field.

**Index (1-15) in Schedule Setup** - You can type in four sets of time schedule for your request. All the schedules can be set previously in **Application – Schedule** web page and you can use the number that you have set in that web page.

**ISDN Dial Backup Setup**

This setting is available for the routers supporting ISDN function only. Before utilizing the ISDN dial backup feature, you must create a dial backup profile first.

**None** - Disable the backup function.

**Packet Trigger** -The backup line is not on until a packet from a local host triggers the router to establish a connection.

This setting is available for *i* model only.

Dial Backup Mode 

- None
- Packet Trigger

## PPP Setup

**PPP Authentication** - Select **PAP only** or **PAP or CHAP** for PPP.  
**Idle Timeout** - Set the timeout for breaking down the Internet after passing through the time without any action. This setting is active only when the **Active on demand** option for Active Mode is selected in **WAN>> General Setup** page.

## IP Address Assignment Method(IPCP)

**Fixed IP** - Usually ISP dynamically assigns IP address to you each time you connect to it and request. In some case, your ISP provides service to always assign you the same IP address whenever you request. In this case, you can fill in this IP address in the Fixed IP field. Please contact your ISP before you want to use this function. Click **Yes** to use this function and type in a fixed IP address in the box.

**Fixed IP Address** -Type a fixed IP address.

**WAN IP Alias** - If you have multiple public IP addresses and would like to utilize them on the WAN interface, please use WAN IP Alias. You can set up to 8 public IP addresses other than the current one you are using. Notice that this setting is available for WAN1 only.

Index	Enable	Aux. WAN IP	Join NAT IP Pool
1.	<input checked="" type="checkbox"/>	172.16.3.229	<input checked="" type="checkbox"/>
2.	<input type="checkbox"/>	<input type="text"/>	<input type="checkbox"/>
3.	<input type="checkbox"/>	<input type="text"/>	<input type="checkbox"/>
4.	<input type="checkbox"/>	<input type="text"/>	<input type="checkbox"/>
5.	<input type="checkbox"/>	<input type="text"/>	<input type="checkbox"/>
6.	<input type="checkbox"/>	<input type="text"/>	<input type="checkbox"/>
7.	<input type="checkbox"/>	<input type="text"/>	<input type="checkbox"/>
8.	<input type="checkbox"/>	<input type="text"/>	<input type="checkbox"/>

OK Clear All Close

**Default MAC Address** – Click this radio button to use default MAC address for the router.

**Specify a MAC Address** - Some Cable service providers specify a specific MAC address for access authentication. In such cases you need to click the **Specify a MAC Address** and enter the MAC address in the MAC Address field.

## WAN IP Network Settings

**Obtain an IP address automatically** – Click this button to obtain the IP address automatically.

**Specify an IP address** – Click this radio button to specify some data.

**IP Address** – Type the IP address.

**Subnet Mask** – Type the subnet mask.

### 3.1.4 Load-Balance Policy

This router supports the function of load balancing. It can assign traffic with protocol type, IP address for specific host, a subnet of hosts, and port range to be allocated in WAN1 or WAN2 interface. The user can assign traffic category and force it to go to dedicate network interface based on the following web page setup. Twenty policies of load-balance are supported by this router.

**Note:** Load-Balance Policy is running only when both WAN1 and WAN2 are activated.

WAN >> Load-Balance Policy

#### Load-Balance Policy

Index	Enable	Protocol	WAN	Src IP Start	Src IP End	Dest IP Start	Dest IP End	Dest Port Start	Dest Port End
1	<input type="checkbox"/>	any	WAN1						
2	<input type="checkbox"/>	any	WAN1						
3	<input type="checkbox"/>	any	WAN1						
4	<input type="checkbox"/>	any	WAN1						
5	<input type="checkbox"/>	any	WAN1						
6	<input type="checkbox"/>	any	WAN1						
7	<input type="checkbox"/>	any	WAN1						
8	<input type="checkbox"/>	any	WAN1						
9	<input type="checkbox"/>	any	WAN1						
10	<input type="checkbox"/>	any	WAN1						

<< 1-10 | 11-20 >>

Next >>

OK

**Index** Click the number of index to access into the load-balance policy configuration web page.

**Enable** Check this box to enable this policy.

**Protocol** Use the drop-down menu to change the protocol for the WAN interface.

**WAN** Use the drop-down menu to change the WAN interface.

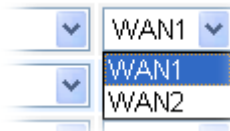

**Src IP Start** Displays the IP address for the start of the source IP.

**Src IP End** Displays the IP address for the end of the source IP.

**Dest IP Start** Displays the IP address for the start of the destination IP.

**Dest IP End** Displays the IP address for the end of the destination IP.

**Dest Port Start** Displays the IP address for the start of the destination port.

**Dest Port End** Displays the IP address for the end of the destination port.

Click **Index 1** to access into the following page for configuring load-balance policy.

**WAN >> Load-Balance Policy**

**Index: 1**

<input type="checkbox"/> Enable	
Protocol	TCP
Binding WAN interface	WAN1
Src IP Start	192.168.1.3
Src IP End	192.168.1.5
Dest IP Start	168.95.0.0
Dest IP End	168.95.0.100
Dest Port Start	80
Dest Port End	100

OK

Cancel

**Enable** Check this box to enable this policy.

**Protocol** Use the drop-down menu to choose a proper protocol for the WAN interface.

Protocol	any
	any
	TCP
	UDP
	TCP/UDP
	ICMP
	IGMP

**Binding WAN interface** Choose the WAN interface (WAN1 or WAN2) for binding.

**Src IP Start** Type the source IP start for the specified WAN interface.

**Src IP End** Type the source IP end for the specified WAN interface. If this field is blank, it means that all the source IPs inside the LAN will be passed through the WAN interface.

**Dest IP Start** Type the destination IP start for the specified WAN interface.

**Dest IP End** Type the destination IP end for the specified WAN interface. If this field is blank, it means that all the destination IPs will be passed through the WAN interface.

**Dest Port Start** Type the destination port start for the destination IP.

**Dest Port End** Type the destination port end for the destination IP. If this field is blank, it means that all the destination ports will be passed through the WAN interface.

## 3.2 LAN

Local Area Network (LAN) is a group of subnets regulated and ruled by router. The design of network structure is related to what type of public IP addresses coming from your ISP.

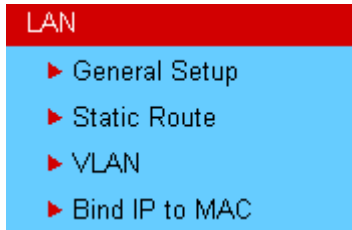

### 3.2.1 Basics of LAN

The most generic function of Vigor router is NAT. It creates a private subnet of your own. As mentioned previously, the router will talk to other public hosts on the Internet by using public IP address and talking to local hosts by using its private IP address. What NAT does is to translate the packets from public IP address to private IP address to forward the right packets to the right host and vice versa. Besides, Vigor router has a built-in DHCP server that assigns private IP address to each local host. See the following diagram for a briefly understanding.

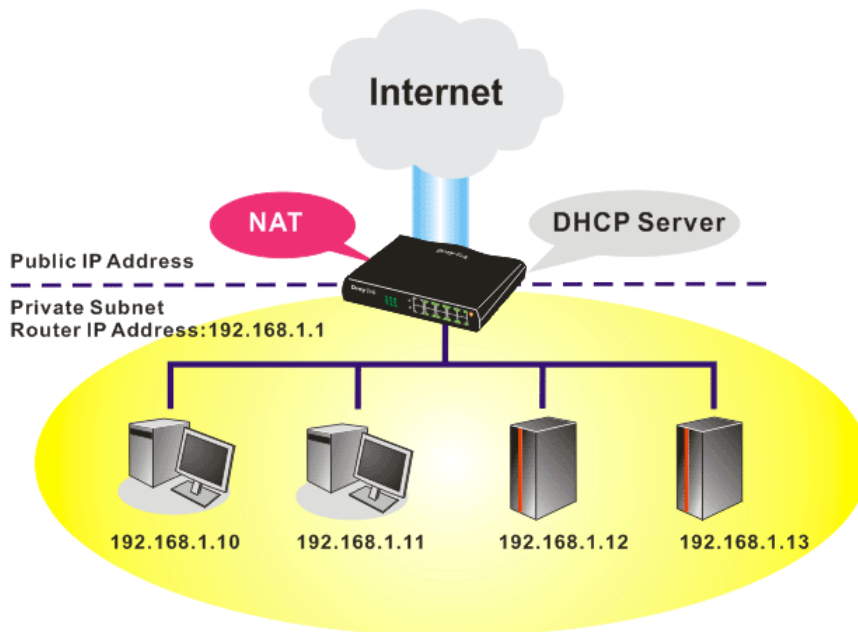

In some special case, you may have a public IP subnet from your ISP such as 220.135.240.0/24. This means that you can set up a public subnet or call second subnet that each host is equipped with a public IP address. As a part of the public subnet, the Vigor router will serve for IP routing to help hosts in the public subnet to communicate with other public hosts or servers outside. Therefore, the router should be set as the gateway for public hosts.

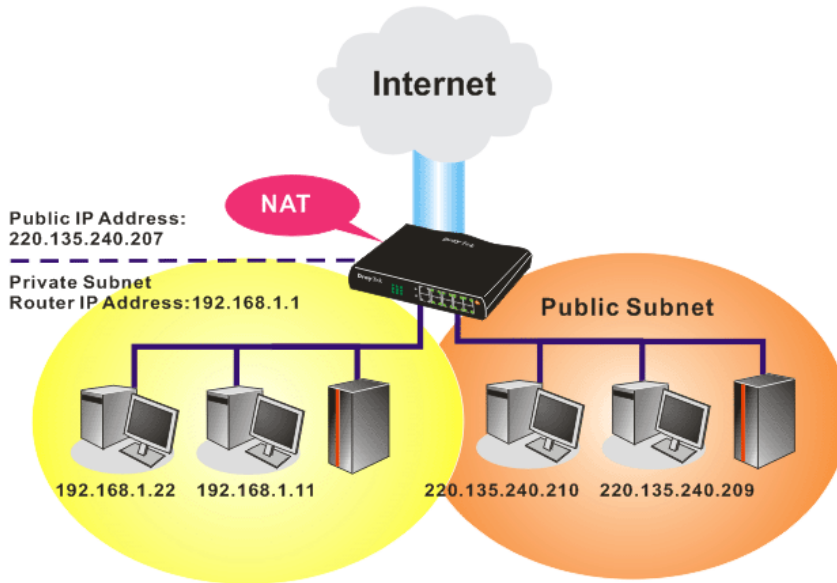

### What is Routing Information Protocol (RIP)

Vigor router will exchange routing information with neighboring routers using the RIP to accomplish IP routing. This allows users to change the information of the router such as IP address and the routers will automatically inform for each other.

### What is Static Route

When you have several subnets in your LAN, sometimes a more effective and quicker way for connection is the **Static routes** function rather than other method. You may simply set rules to forward data from one specified subnet to another specified subnet without the presence of RIP.

### What are Virtual LANs and Rate Control

You can group local hosts by physical ports and create up to 4 virtual LANs. To manage the communication between different groups, please set up rules in Virtual LAN (VLAN) function and the rate of each.

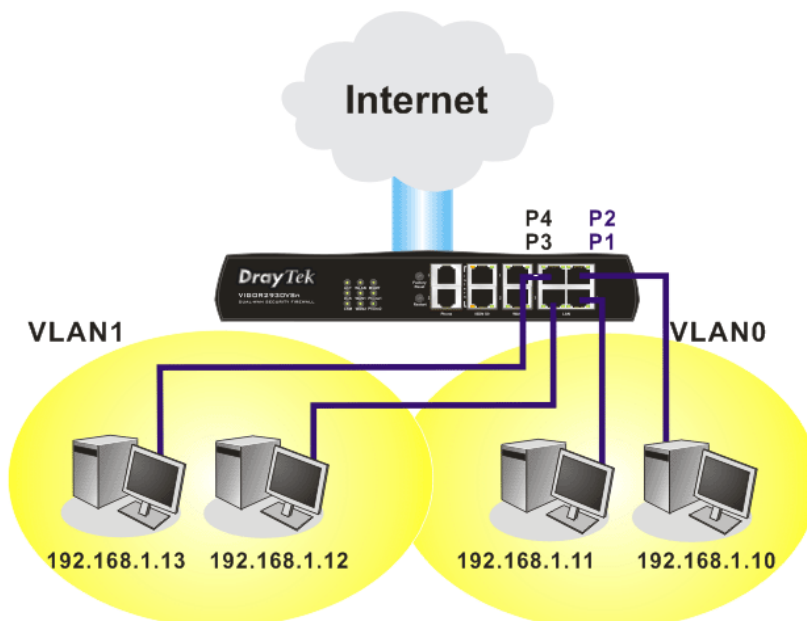



### 3.2.2 General Setup

This page provides you the general settings for LAN.

Click **LAN** to open the LAN settings page and choose **General Setup**.

LAN >> General Setup

**Ethernet TCP / IP and DHCP Setup**

<b>LAN IP Network Configuration</b>		<b>DHCP Server Configuration</b>	
For NAT Usage		<input checked="" type="radio"/> Enable Server <input type="radio"/> Disable Server	
1st IP Address	<input type="text" value="192.168.1.1"/>	Relay Agent:	<input type="radio"/> 1st Subnet <input type="radio"/> 2nd Subnet
1st Subnet Mask	<input type="text" value="255.255.255.0"/>	Start IP Address	<input type="text" value="192.168.1.10"/>
For IP Routing Usage <input type="radio"/> Enable <input checked="" type="radio"/> Disable		IP Pool Counts	<input type="text" value="50"/>
2nd IP Address	<input type="text" value="192.168.2.1"/>	Gateway IP Address	<input type="text" value="192.168.1.1"/>
2nd Subnet Mask	<input type="text" value="255.255.255.0"/>	DHCP Server IP Address for Relay Agent	<input type="text"/>
<input checked="" type="checkbox"/> 2nd Subnet DHCP Server		<b>DNS Server IP Address</b>	
RIP Protocol Control <input type="text" value="Disable"/>		<input type="checkbox"/> Force DNS manual setting	
		Primary IP Address	<input type="text" value="168.95.1.1"/>
		Secondary IP Address	<input type="text"/>

- 1st IP Address** Type in private IP address for connecting to a local private network (Default: 192.168.1.1).
- 1st Subnet Mask** Type in an address code that determines the size of the network. (Default: 255.255.255.0/ 24)
- For IP Routing Usage** Click **Enable** to invoke this function. The default setting is **Disable**.
- 2<sup>nd</sup> IP Address** Type in secondary IP address for connecting to a subnet. (Default: 192.168.2.1/ 24)
- 2<sup>nd</sup> Subnet Mask** An address code that determines the size of the network. (Default: 255.255.255.0/ 24)
- 2<sup>nd</sup> DHCP Server** You can configure the router to serve as a DHCP server for the 2nd subnet.

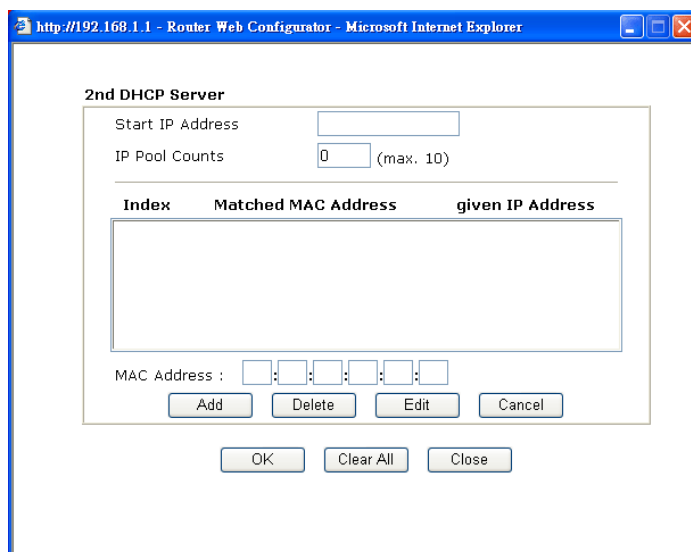

**Start IP Address:** Enter a value of the IP address pool for the DHCP server to start with when issuing IP addresses. If the 2nd IP address of your router is 220.135.240.1, the starting IP address must be 220.135.240.2 or greater, but smaller than 220.135.240.254.

**IP Pool Counts:** Enter the number of IP addresses in the pool. The maximum is 10. For example, if you type 3 and the 2nd IP address of your router is 220.135.240.1, the range of IP address by the DHCP server will be from 220.135.240.2 to 220.135.240.11.

**MAC Address:** Enter the MAC Address of the host one by one and click **Add** to create a list of hosts to be assigned, deleted or edited IP address from above pool. Set a list of MAC Address for 2<sup>nd</sup> DHCP server will help router to assign the correct IP address of the correct subnet to the correct host. So those hosts in 2<sup>nd</sup> subnet won't get an IP address belonging to 1<sup>st</sup> subnet.

### RIP Protocol Control

**Disable** deactivates the RIP protocol. It will lead to a stoppage of the exchange of routing information between routers. (Default)

RIP Protocol Control

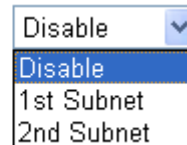

**1st Subnet** - Select the router to change the RIP information of the 1st subnet with neighboring routers.

**2nd Subnet** - Select the router to change the RIP information of the 2nd subnet with neighboring routers.

### DHCP Server Configuration

DHCP stands for Dynamic Host Configuration Protocol. The router by factory default acts a DHCP server for your network so it automatically dispatch related IP settings to any local user configured as a DHCP client. It is highly recommended that you leave the router enabled as a DHCP server if you do not have a DHCP server for your network.

If you want to use another DHCP server in the network other than the Vigor Router's, you can let Relay Agent help you to redirect the DHCP request to the specified location.

**Enable Server** - Let the router assign IP address to every host in the LAN.

**Disable Server** - Let you manually assign IP address to every host in the LAN.

**Relay Agent** - (1<sup>st</sup> subnet/2<sup>nd</sup> subnet) Specify which subnet that DHCP server is located the relay agent should redirect the DHCP request to.

**Start IP Address** - Enter a value of the IP address pool for the DHCP server to start with when issuing IP addresses. If the 1st IP address of your router is 192.168.1.1, the starting IP address must be 192.168.1.2 or greater, but smaller than 192.168.1.254.

**IP Pool Counts** - Enter the maximum number of PCs that you want the DHCP server to assign IP addresses to. The default is 50 and the maximum is 253.

**Gateway IP Address** - Enter a value of the gateway IP address for the DHCP server. The value is usually as same as the 1st IP address of the router, which means the router is the default gateway.

## DNS Server Configuration

**DHCP Server IP Address for Relay Agent** - Set the IP address of the DHCP server you are going to use so the Relay Agent can help to forward the DHCP request to the DHCP server.

DNS stands for Domain Name System. Every Internet host must have a unique IP address, also they may have a human-friendly, easy to remember name such as www.yahoo.com. The DNS server converts the user-friendly name into its equivalent IP address.

**Force DNS manual setting** - Force router to use DNS servers in this page instead of DNS servers given by the Internet Access server (PPPoE, PPTP, L2TP or DHCP server).

**Primary IP Address** - You must specify a DNS server IP address here because your ISP should provide you with usually more than one DNS Server. If your ISP does not provide it, the router will automatically apply default DNS Server IP address: 194.109.6.66 to this field.

**Secondary IP Address** - You can specify secondary DNS server IP address here because your ISP often provides you more than one DNS Server. If your ISP does not provide it, the router will automatically apply default secondary DNS Server IP address: 194.98.0.1 to this field.

The default DNS Server IP address can be found via Online Status:

System Status			System Uptime: 0:53:43	
LAN Status		Primary DNS: 168.95.1.1	Secondary DNS: 168.95.1.1	
IP Address	TX Packets	RX Packets		
192.168.1.1	1878	1739		

If both the Primary IP and Secondary IP Address fields are left empty, the router will assign its own IP address to local users as a DNS proxy server and maintain a DNS cache.

If the IP address of a domain name is already in the DNS cache, the router will resolve the domain name immediately. Otherwise, the router forwards the DNS query packet to the external DNS server by establishing a WAN (e.g. DSL/Cable) connection.

There are two common scenarios of LAN settings that stated in Chapter 4. For the configuration examples, please refer to that chapter to get more information for your necessity.

### 3.2.3 Static Route

Go to **LAN** to open setting page and choose **Static Route**.

LAN >> Static Route Setup

Static Route Configuration			Set to Factory Default		View Routing Table	
Index	Destination Address	Status	Index	Destination Address	Status	
<u>1.</u>	???	?	<u>6.</u>	???	?	
<u>2.</u>	???	?	<u>7.</u>	???	?	
<u>3.</u>	???	?	<u>8.</u>	???	?	
<u>4.</u>	???	?	<u>9.</u>	???	?	
<u>5.</u>	???	?	<u>10.</u>	???	?	

**Status:** v --- Active, x --- Inactive, ? --- Empty

#### Index

The number (1 to 10) under Index allows you to open next page to set up static route.

**Destination Address** Displays the destination address of the static route.

**Status** Displays the status of the static route.

**Viewing Routing Table** Displays the routing table for your reference.

Diagnostics >> View Routing Table

Current Running Routing Table		Refresh
Key: C - connected, S - static, R - RIP, * - default, ~ - private		
* 0.0.0.0/	0.0.0.0 via 172.16.3.1,	WAN1
C~ 192.168.1.0/	255.255.255.0 is directly connected,	LAN
C 172.16.3.0/	255.255.255.0 is directly connected,	WAN1

## Add Static Routes to Private and Public Networks

Here is an example of setting Static Route in Main Router so that user A and B locating in different subnet can talk to each other via the router. Assuming the Internet access has been configured and the router works properly:

- use the Main Router to surf the Internet.
- create a private subnet 192.168.10.0 using an internal Router A (192.168.1.2)
- create a public subnet 211.100.88.0 via an internal Router B (192.168.1.3).
- have set Main Router 192.168.1.1 as the default gateway for the Router A 192.168.1.2.

Before setting Static Route, user A cannot talk to user B for Router A can only forward recognized packets to its default gateway Main Router.

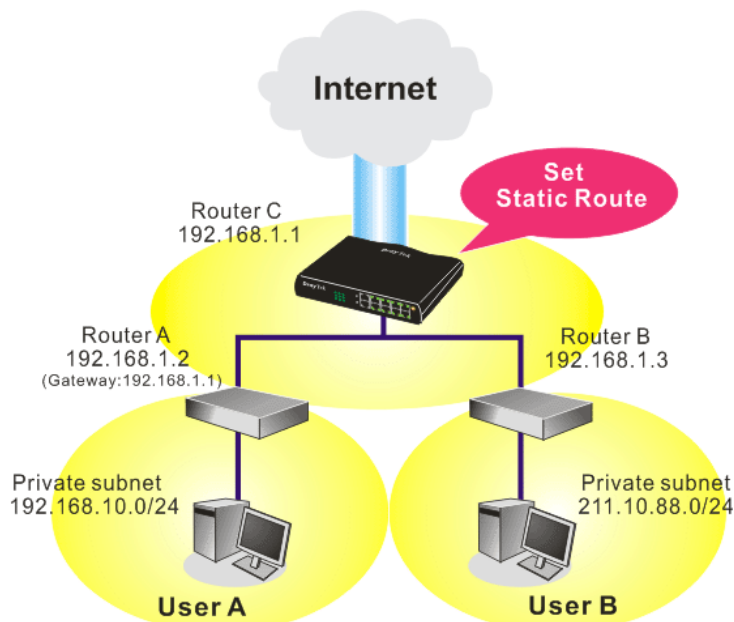

Go to **LAN** page and click **General Setup**, select 1st Subnet as the **RIP Protocol Control**. Then click the **OK** button.

**Note:** There are two reasons that we have to apply RIP Protocol Control on 1st Subnet. The first is that the LAN interface can exchange RIP packets with the neighboring routers via the 1st subnet (192.168.1.0/24). The second is that those hosts on the internal private subnets (ex. 192.168.10.0/24) can access the Internet via the router, and continuously exchange of IP routing information with different subnets.

1. Click the **LAN - Static Route** and click on the **Index Number 1**. Check the **Enable** box. Please add a static route as shown below, which regulates all packets destined to 192.168.10.0 will be forwarded to 192.168.1.2. Click **OK**.

LAN >> Static Route Setup

**Index No. 1**

Enable

Destination IP Address: 192.168.10.0

Subnet Mask: 255.255.255.0

Gateway IP Address: 192.168.1.2

Network Interface: LAN

OK Cancel

2. Return to **Static Route Setup** page. Click on another **Index Number** to add another static route as show below, which regulates all packets destined to 211.100.88.0 will be forwarded to 192.168.1.3.

LAN >> Static Route Setup

**Index No. 1**

Enable

Destination IP Address: 211.100.88.0

Subnet Mask: 255.255.255.0

Gateway IP Address: 192.168.1.3

Network Interface: LAN

OK Cancel

3. Go to **Diagnostics** and choose **Routing Table** to verify current routing table.

Diagnostics >> View Routing Table

Current Running Routing Table Refresh

```

Key: C - connected, S - static, R - RIP, * - default, ~ - private
*      0.0.0.0/      0.0.0.0 via 172.16.3.1,   WAN1
S~    192.168.10.0/  255.255.255.0 via 192.168.1.2,  LAN
C~    192.168.1.0/   255.255.255.0 is directly connected,  LAN
C      172.16.3.0/   255.255.255.0 is directly connected,  WAN1
S~    211.100.88.0/  255.255.255.0 via 192.168.1.3,   LAN
  
```

### 3.2.4 VLAN

Virtual LAN function provides you a very convenient way to manage hosts by grouping them based on the physical port. You can also manage the in/out rate of each port. Go to **LAN** page and select **VLAN**. The following page will appear. Click **Enable** to invoke VLAN function.

LAN >> VLAN Configuration

**VLAN Configuration**

Enable

	P1	P2	P3	P4
VLAN0	<input type="checkbox"/>	<input type="checkbox"/>	<input type="checkbox"/>	<input type="checkbox"/>
VLAN1	<input type="checkbox"/>	<input type="checkbox"/>	<input type="checkbox"/>	<input type="checkbox"/>
VLAN2	<input type="checkbox"/>	<input type="checkbox"/>	<input type="checkbox"/>	<input type="checkbox"/>
VLAN3	<input type="checkbox"/>	<input type="checkbox"/>	<input type="checkbox"/>	<input type="checkbox"/>

OK Clear Cancel

To add or remove a VLAN, please refer to the following example.

1. If, VLAN 0 is consisted of hosts linked to P1 and P2 and VLAN 1 is consisted of hosts linked to P3 and P4.

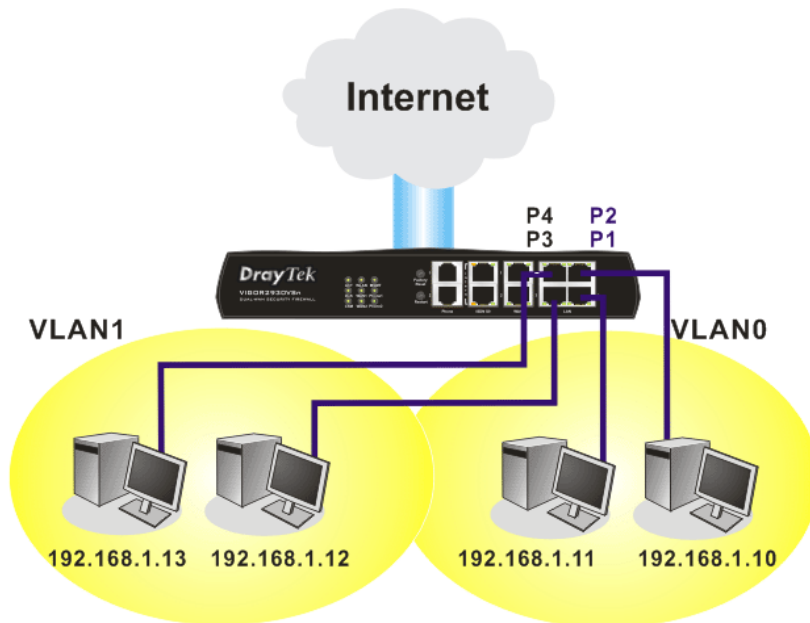

- After checking the box to enable VLAN function, you will check the table according to the needs as shown below.

LAN >> VLAN Configuration

**VLAN Configuration**

Enable

	P1	P2	P3	P4
VLAN0	<input checked="" type="checkbox"/>	<input checked="" type="checkbox"/>	<input type="checkbox"/>	<input type="checkbox"/>
VLAN1	<input type="checkbox"/>	<input type="checkbox"/>	<input checked="" type="checkbox"/>	<input checked="" type="checkbox"/>
VLAN2	<input type="checkbox"/>	<input type="checkbox"/>	<input type="checkbox"/>	<input type="checkbox"/>
VLAN3	<input type="checkbox"/>	<input type="checkbox"/>	<input type="checkbox"/>	<input type="checkbox"/>

OK Clear Cancel

To remove VLAN, uncheck the needed box and click **OK** to save the results.

### 3.2.5 Bind IP to MAC

This function is used to bind the IP and MAC address in LAN to have a strengthened control in network. When this function is enabled, all the assigned IP and MAC address binding together cannot be changed. If you modified the binding IP or MAC address, it might cause you not access into the Internet.

Click **LAN** and click **Bind IP to MAC** to open the setup page.

LAN >> Bind IP to MAC

**Bind IP to MAC**

**Note:** IP-MAC binding presets DHCP Allocations.  
If you select Strict Bind, unspecified LAN clients cannot access the Internet.

Enable  Disable  Strict Bind

**ARP Table** | [Select All](#) | [Sort](#) | [Refresh](#) | **IP Bind List** | [Select All](#) | [Sort](#) |

IP Address	Mac Address	Index	IP Address	Mac Address
192.168.1.10	00-0E-A6-2A-D5-A1			
192.168.1.100	00-08-A1-36-97-5D			
192.168.1.11	00-13-D4-A4-99-92			
192.168.1.12	00-0B-CD-55-CB-45			
192.168.1.10	00-13-D4-A4-99-92			
192.168.1.123	00-08-A1-01-53-BB			

**Add and Edit**

IP Address

Mac Address  :  :  :  :  :

Add Edit Delete

**Enable** Click this radio button to invoke this function. However, IP/MAC which is not listed in IP Bind List also can connect to Internet.

**Disable** Click this radio button to disable this function. All the settings on this page will be invalid.

**Strict Bind** Click this radio button to block the connection of the IP/MAC which is not listed in IP Bind List.

**ARP Table** This table is the LAN ARP table of this router. The information for IP and MAC will be displayed in this field. Each pair of IP

and MAC address listed in ARP table can be selected and added to IP Bind List by clicking **Add** below.

**Add and Edit**

**IP Address** – Type the IP address that will be used for the specified MAC address.

**Mac Address** – Type the MAC address that is used to bind with the assigned IP address.

**Refresh**

It is used to refresh the ARP table. When there is one new PC added to the LAN, you can click this link to obtain the newly ARP table information.

**IP Bind List**

It displays a list for the IP bind to MAC information.

**Add**

It allows you to add the one you choose from the ARP table or the IP/MAC address typed in **Add and Edit** to the table of **IP Bind List**.

**Edit**

It allows you to edit and modify the selected IP address and MAC address that you create before.

**Delete**

You can remove any item listed in **IP Bind List**. Simply click and select the one, and click **Delete**. The selected item will be removed from the **IP Bind List**.

**Note:** Before you select **Strict Bind**, you have to bind one set of IP/MAC address for one PC. If not, no one of the PCs can access into Internet. And the web configurator of the router might not be accessed.

### 3.3 NAT

Usually, the router serves as an NAT (Network Address Translation) router. NAT is a mechanism that one or more private IP addresses can be mapped into a single public one. Public IP address is usually assigned by your ISP, for which you may get charged. Private IP addresses are recognized only among internal hosts.

When the outgoing packets destined to some public server on the Internet reach the NAT router, the router will change its source address into the public IP address of the router, select the available public port, and then forward it. At the same time, the router shall list an entry in a table to memorize this address/port-mapping relationship. When the public server response, the incoming traffic, of course, is destined to the router's public IP address and the router will do the inversion based on its table. Therefore, the internal host can communicate with external host smoothly.

The benefit of the NAT includes:

- **Save cost on applying public IP address and apply efficient usage of IP address.** NAT allows the internal IP addresses of local hosts to be translated into one public IP address, thus you can have only one IP address on behalf of the entire internal hosts.
- **Enhance security of the internal network by obscuring the IP address.** There are many attacks aiming victims based on the IP address. Since the attacker cannot be aware of any private IP addresses, the NAT function can protect the internal network.

On NAT page, you will see the private IP address defined in RFC-1918. Usually we use the 192.168.1.0/24 subnet for the router. As stated before, the NAT facility can map one or more IP addresses and/or service ports into different specified services. In other words, the NAT function can be achieved by using port mapping methods.

Below shows the menu items for NAT.



- NAT**
- ▶ Port Redirection
- ▶ DMZ Host
- ▶ Open Ports

### 3.3.1 Port Redirection

Port Redirection is usually set up for server related service inside the local network (LAN), such as web servers, FTP servers, E-mail servers etc. Most of the case, you need a public IP address for each server and this public IP address/domain name are recognized by all users. Since the server is actually located inside the LAN, the network well protected by NAT of the router, and identified by its private IP address/port, the goal of Port Redirection function is to forward all access request with public IP address from external users to the mapping private IP address/port of the server.

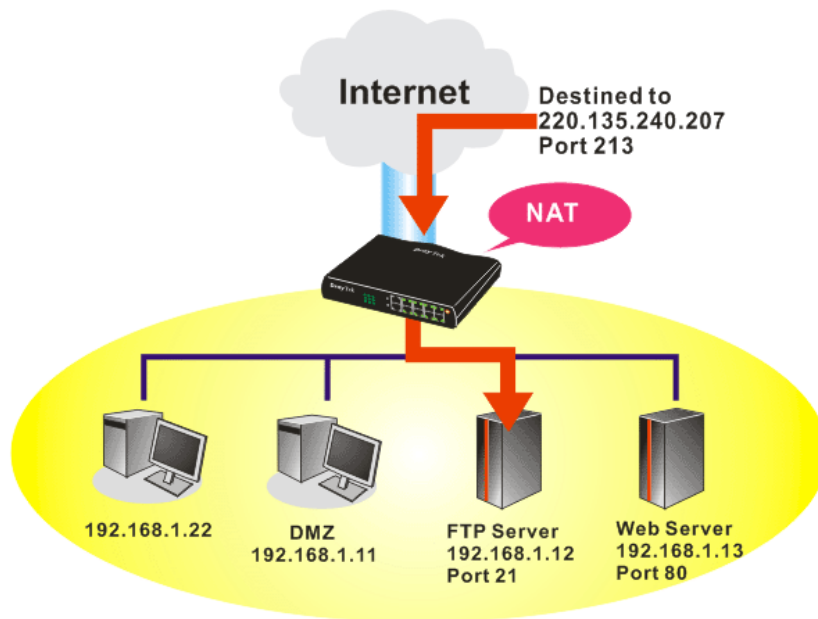

The port redirection can only apply to incoming traffic.

To use this function, please go to **NAT** page and choose **Port Redirection** web page. The **Port Redirection Table** provides 20 port-mapping entries for the internal hosts.

NAT >> Port Redirection

Port Redirection

[Set to Factory Default](#)

Index	Service Name	Public Port	Private IP	Status
1.				x
2.				x
3.				x
4.				x
5.				x
6.				x
7.				x
8.				x
9.				x
10.				x

<< [1-10](#) | [11-20](#) >>

[Next](#) >>

Press any number under Index to access into next page for configuring port redirection.

NAT >> Port Redirection

Index No. 1

Enable

Mode: Range

Service Name:

Protocol: TCP

WAN IP: 2.WAN IP Alias[1]172.16.3.229

Public Port:  -

Private IP:  -

Private Port:

**Note:** In "Range" Mode the End IP will be calculated automatically once the Public Port and Start IP have been entered.

**Enable**

Check this box to enable such port redirection setting.

**Mode**

Two options (Single and Range) are provided here for you to choose. To set a range for the specific service, select **Range**. In Range mode, if the public port (start port and end port) and the starting IP of private IP had been entered, the system will calculate and display the ending IP of private IP automatically.

**Service Name**

Enter the description of the specific network service.

**Protocol**

Select the transport layer protocol (TCP or UDP).

**Public Port**

Specify which port can be redirected to the specified **Private IP and Port** of the internal host. If you choose **Range** as the port redirection mode, you will see two boxes on this field. Simply type the required numbers on these two boxes.

**Private IP**

Specify the private IP address of the internal host providing the service. If you choose **Range** as the port redirection mode, you will see two boxes on this field. Simply type the IP address in the first

box (as the starting point). The second one is assigned automatically after you type the private port number below.

**Private Port**

Specify the private port number of the service offered by the internal host. After you enter the proper number in this box, the second box of Private IP address will be assigned accordingly.

**Active**

Check this box to activate the port-mapping entry you have defined.

Note that the router has its own built-in services (servers) such as Telnet, HTTP and FTP etc. Since the common port numbers of these services (servers) are all the same, you may need to reset the router in order to avoid confliction.

For example, the built-in web configurator in the router is with default port 80, which may conflict with the web server in the local network, http://192.168.1.13:80. Therefore, you need to **change the router's http port to any one other than the default port 80** to avoid conflict, such as 8080. This can be set in the **System Maintenance >>Management Setup**. You then will access the admin screen of by suffixing the IP address with 8080, e.g., http://192.168.1.1:8080 instead of port 80.

System Maintenance >> Management

**Management Setup**

<b>Management Access Control</b> <input type="checkbox"/> Allow management from the Internet <input type="checkbox"/> FTP Server <input checked="" type="checkbox"/> HTTP Server <input checked="" type="checkbox"/> HTTPS Server <input checked="" type="checkbox"/> Telnet Server <input checked="" type="checkbox"/> Disable PING from the Internet	<b>Management Port Setup</b> <input checked="" type="radio"/> User Define Ports <input type="radio"/> Default Ports Telnet Port <input type="text" value="23"/> (Default: 23) HTTP Port <input type="text" value="80"/> (Default: 80) HTTPS Port <input type="text" value="443"/> (Default: 443) FTP Port <input type="text" value="21"/> (Default: 21)
<b>Access List</b> List      IP      Subnet Mask 1 <input type="text"/> <input type="text"/> <input type="button" value="v"/> 2 <input type="text"/> <input type="text"/> <input type="button" value="v"/> 3 <input type="text"/> <input type="text"/> <input type="button" value="v"/>	<b>SNMP Setup</b> <input type="checkbox"/> Enable SNMP Agent Get Community <input type="text" value="public"/> Set Community <input type="text" value="private"/> Manager Host IP <input type="text"/> Trap Community <input type="text" value="public"/> Notification Host IP <input type="text"/> Trap Timeout <input type="text" value="10"/> seconds

### 3.3.2 DMZ Host

As mentioned above, **Port Redirection** can redirect incoming TCP/UDP or other traffic on particular ports to the specific private IP address/port of host in the LAN. However, other IP protocols, for example Protocols 50 (ESP) and 51 (AH), do not travel on a fixed port. Vigor router provides a facility **DMZ Host** that maps ALL unsolicited data on any protocol to a single host in the LAN. Regular web surfing and other such Internet activities from other clients will continue to work without inappropriate interruption. **DMZ Host** allows a defined internal user to be totally exposed to the Internet, which usually helps some special applications such as Netmeeting or Internet Games etc.

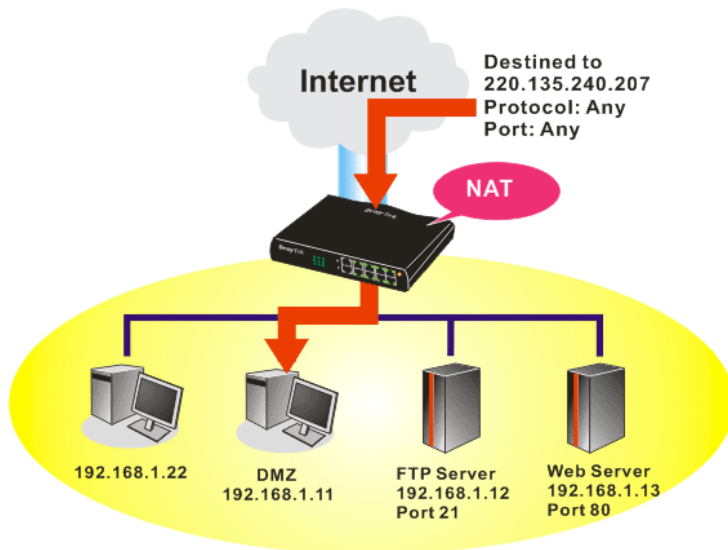

**Note:** The inherent security properties of NAT are somewhat bypassed if you set up DMZ host. We suggest you to add additional filter rules or a secondary firewall.

Click **DMZ Host** to open the following page:

NAT >> DMZ Host Setup

**DMZ Host Setup**

**WAN 1**

Active True IP

**Private IP**

**MAC Address of the True IP DMZ Host**

Note: When a True-IP DMZ host is turned on, it will force the router's WAN connection to be always on.

---

**WAN 2**

Enable

**Private IP**

- WAN1** This page allows you to configure **Private IP** or **Active True IP** as DMZ host.
- Private IP** If you choose **Private IP** as DMZ host, you can type a private IP in this box or use Choose PC button to choose the one you want.
- MAC Address of the** If you choose **Active True IP** as DMZ host, please type the

**True....** MAC address of the one you want.

If you previously have set up **WAN Alias** in **Internet Access>>PPPoE**, you will find them in **Aux. WAN IP list** for your selection.

**NAT >> DMZ Host Setup**

**DMZ Host Setup**

WAN 1			
Index	Enable	Aux. WAN IP	Private IP
1.	<input type="checkbox"/>	172.16.3.229	<input type="text"/> <input type="button" value="Choose PC"/>
2.	<input type="checkbox"/>	172.16.3.22	<input type="text"/> <input type="button" value="Choose PC"/>

  

WAN 2	
Enable	Private IP
<input type="checkbox"/>	<input type="text"/> <input type="button" value="Choose PC"/>

**Enable** Check to enable the DMZ Host function.

**Private IP** Enter the private IP address of the DMZ host, or click **Choose PC** to select one.

**Choose PC** Click this button and then a window will automatically pop up, as depicted below. The window consists of a list of private IP addresses of all hosts in your LAN network. Select one private IP address in the list to be the DMZ host.

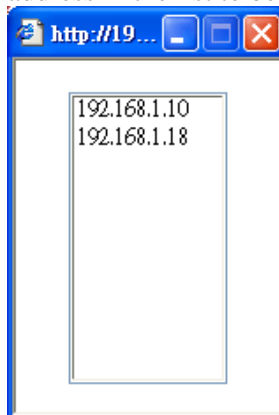

When you have selected one private IP from the above dialog, the IP address will be shown on the following screen. Click **OK** to save the setting.

**NAT >> DMZ Host Setup**

**DMZ Host Setup**

WAN 1			
Index	Enable	Aux. WAN IP	Private IP
1.	<input checked="" type="checkbox"/>	172.16.3.229	192.168.1.10 <input type="button" value="Choose PC"/>
2.	<input type="checkbox"/>	172.16.3.22	<input type="text"/> <input type="button" value="Choose PC"/>

WAN 2	
Enable	Private IP
<input type="checkbox"/>	<input type="text"/> <input type="button" value="Choose PC"/>

### 3.3.3 Open Ports

**Open Ports** allows you to open a range of ports for the traffic of special applications. Common application of Open Ports includes P2P application (e.g., BT, KaZaA, Gnutella, WinMX, eMule and others), Internet Camera etc. Ensure that you keep the application involved up-to-date to avoid falling victim to any security exploits.

Click **Open Ports** to open the following page:

NAT >> Open Ports

Open Ports Setup				<a href="#">Set to Factory Default</a>
Index	Comment	WAN Interface	Local IP Address	Status
<a href="#">1.</a>				X
<a href="#">2.</a>				X
<a href="#">3.</a>				X
<a href="#">4.</a>				X
<a href="#">5.</a>				X
<a href="#">6.</a>				X
<a href="#">7.</a>				X
<a href="#">8.</a>				X
<a href="#">9.</a>				X
<a href="#">10.</a>				X

<< [1-10](#) | [11-20](#) >> [Next](#) >>

- Index** Indicate the relative number for the particular entry that you want to offer service in a local host. You should click the appropriate index number to edit or clear the corresponding entry.
- Comment** Specify the name for the defined network service.
- WAN Interface** Display the WAN interface for the entry.
- Local IP Address** Display the private IP address of the local host offering the service.
- Status** Display the state for the corresponding entry. X or V is to represent the **Inactive** or **Active** state.

To add or edit port settings, click one index number on the page. The index entry setup page will pop up. In each index entry, you can specify **10** port ranges for diverse services.

NAT >> Open Ports >> Edit Open Ports

Index No. 1

Enable Open Ports

Comment: P2P

WAN Interface: WAN1

Local Computer: 192.168.1.10

	Protocol	Start Port	End Port		Protocol	Start Port	End Port
1.	TCP	4500	4700	6.	-----	0	0
2.	UDP	4500	4700	7.	-----	0	0
3.	-----	0	0	8.	-----	0	0
4.	-----	0	0	9.	-----	0	0
5.	-----	0	0	10.	-----	0	0

- Enable Open Ports** Check to enable this entry.
- Comment** Make a name for the defined network application/service.
- WAN Interface** Specify the WAN interface that will be used for this entry.
- Local Computer** Enter the private IP address of the local host or click **Choose PC** to select one.
- Choose PC** Click this button and, subsequently, a window having a list of private IP addresses of local hosts will automatically pop up. Select the appropriate IP address of the local host in the list.
- Protocol** Specify the transport layer protocol. It could be **TCP**, **UDP**, or **-----** (none) for selection.
- Start Port** Specify the starting port number of the service offered by the local host.
- End Port** Specify the ending port number of the service offered by the local host.

## 3.4 Objects Settings

For IPs in a range, service ports in a limited range and keywords usually will be applied for configuring router's settings, we can define them with **objects** and bind them with **groups** for using conveniently. Later, we can select that object/service/keyword for applying. For example, all the IPs in the same department can be defined with an IP object (a range of IP address).

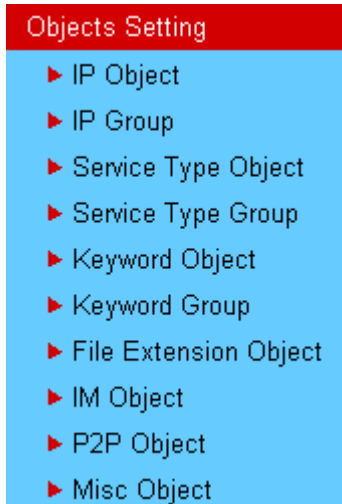

### 3.4.1 IP Object

You can set up to 192 sets of IP Objects with different conditions.

Objects Setting >> IP Object

IP Object Profiles: [Set to Factory Default](#)

Index	Name	Index	Name
1.		17.	
2.		18.	
3.		19.	
4.		20.	
5.		21.	
6.		22.	
7.		23.	
8.		24.	
9.		25.	
10.		26.	
11.		27.	
12.		28.	
13.		29.	
14.		30.	
15.		31.	
16.		32.	

<< 1-32 | 33-64 | 65-96 | 97-128 | 129-160 | 161-192 >> [Next](#) >>

**Set to Factory Default** Clear all profiles.

Click the number under Index column for settings in detail.



**Profile Index : 1**

Name:	RD Department
Interface:	Any
Address Type:	Range Address
Start IP Address:	192.168.1.64
End IP Address:	192.168.1.75
Subnet Mask:	0.0.0.0
Invert Selection:	<input type="checkbox"/>

OK Cancel

**Name** Type a name for this profile. Maximum 15 characters are allowed.

**Interface** Choose a proper interface (WAN, LAN or Any).

Interface:

For example, the **Direction** setting in **Edit Filter Rule** will ask you specify IP or IP range for WAN or LAN or any IP address. If you choose LAN as the **Interface** here, and choose LAN as the direction setting in **Edit Filter Rule**, then all the IP addresses specified with LAN interface will be opened for you to choose in **Edit Filter Rule** page.

**Address Type** Determine the address type for the IP address.  
 Select **Single Address** if this object contains one IP address only.  
 Select **Range Address** if this object contains several IPs within a range.  
 Select **Subnet Address** if this object contains one subnet for IP address.  
 Select **Any Address** if this object contains any IP address.

**Start IP Address** Type the start IP address for Single Address type.

**End IP Address** Type the end IP address if the Range Address type is selected.

**Subnet Mask** Type the subnet mask if the Subnet Address type is selected.

**Invert Select** If it is checked, all the IP addresses except the ones listed above will be applied later while it is chosen.

Below is an example of IP objects settings.

**IP Object Profiles:**

Index	Name
1.	RD Department
2.	Financial Dept.
3.	HR Department
4.	
5.	

### 3.4.2 IP Group

This page allows you to bind several IP objects into one IP group.

Objects Setting >> IP Group

IP Group Table: | [Set to Factory Default](#) |

Index	Name	Index	Name
1.		17.	
2.		18.	
3.		19.	
4.		20.	
5.		21.	
6.		22.	
7.		23.	
8.		24.	
9.		25.	
10.		26.	
11.		27.	
12.		28.	
13.		29.	
14.		30.	
15.		31.	
16.		32.	

**Set to Factory Default**      Clear all profiles.

Click the number under Index column for settings in detail.

Objects Setting >> IP Group

Profile Index : 1

Name:

Interface:  ▾

**Available IP Objects**

1-RD Department  
 2-Financial Dept.  
 3-HR Department

**Selected IP Objects**

(Empty)

**Name**      Type a name for this profile. Maximum 15 characters are allowed.

**Interface**      Choose WAN, LAN or Any to display all the available IP objects with the specified interface.

**Available IP Objects**      All the available IP objects (created in IP Object web page) with the specified interface chosen above will be shown in this box.

**Selected IP Objects**      Click  button to add the selected IP objects in this box.

### 3.4.3 Service Type Object

You can set up to 96 sets of Service Type Objects with different conditions.

Objects Setting >> Service Type Object

Service Type Object Profiles: | [Set to Factory Default](#) |

Index	Name	Index	Name
1.		17.	
2.		18.	
3.		19.	
4.		20.	
5.		21.	
6.		22.	
7.		23.	
8.		24.	
9.		25.	
10.		26.	
11.		27.	
12.		28.	
13.		29.	
14.		30.	
15.		31.	
16.		32.	

<< [1-32](#) | [33-64](#) | [65-96](#) >> [Next](#) >>

**Set to Factory Default** Clear all profiles.

Click the number under Index column for settings in detail.

Objects Setting >> Service Type Object Setup

Profile Index : 1

Name	<input type="text" value="SIP"/>		
Protocol	TCP	<input type="text" value="6"/>	
Source Port	=	<input type="text" value="1"/>	~ <input type="text" value="65535"/>
Destination Port	=	<input type="text" value="80"/>	~ <input type="text" value="80"/>

**Name** Type a name for this profile.

**Protocol** Specify the protocol(s) which this profile will apply to.

- Any
- Any
- ICMP
- TCP
- UDP
- TCP/UDP
- Other

**Source/Destination Port** **Source Port** and the **Destination Port** column are available for TCP/UDP protocol. It can be ignored for other protocols. The filter rule will filter out any port number.

(=) – when the first and last value are the same, it indicates one port; when the first and last values are different, it indicates a range for the port and available for this profile.

(!=) – when the first and last value are the same, it indicates all the ports except the port defined here; when the first and last values are different, it indicates that all the ports except the range defined here are available for this service type.

(>) – the port number greater than this value is available.

(<) – the port number less than this value is available for this profile.

Below is an example of service type objects settings.

**Service Type Object Profiles:**

Index	Name
<u>1.</u>	SIP
<u>2.</u>	RTP
<u>3.</u>	
<u>4.</u>	

### 3.4.4 Service Type Group

This page allows you to bind several service types into one group.

Objects Setting >> Service Type Group

Service Type Group Table:

[Set to Factory Default](#)

Group	Name	Group	Name
<u>1.</u>		<u>17.</u>	
<u>2.</u>		<u>18.</u>	
<u>3.</u>		<u>19.</u>	
<u>4.</u>		<u>20.</u>	
<u>5.</u>		<u>21.</u>	
<u>6.</u>		<u>22.</u>	
<u>7.</u>		<u>23.</u>	
<u>8.</u>		<u>24.</u>	
<u>9.</u>		<u>25.</u>	
<u>10.</u>		<u>26.</u>	
<u>11.</u>		<u>27.</u>	
<u>12.</u>		<u>28.</u>	
<u>13.</u>		<u>29.</u>	
<u>14.</u>		<u>30.</u>	
<u>15.</u>		<u>31.</u>	
<u>16.</u>		<u>32.</u>	

**Set to Factory Default**      Clear all profiles.

Click the number under Index column for setting in detail.

Profile Index : 1

Name:

Available Service Type Objects	Selected Service Type Objects
1-SIP 2-RTP	

- Name** Type a name for this profile.
- Available Service Type Objects** You can add IP objects from IP Object page. All the available IP objects will be shown in this box.
- Selected Service Type Objects** Click  button to add the selected IP objects in this box.

### 3.4.5 Keyword Object

You can set 100 keyword object profiles for choosing as black /white list in **Anti-Spam >>Profile Setting.**

Keyword Object Profiles: | [Set to Factory Default](#) |

Index	Name	Index	Name
<a href="#">1.</a>		<a href="#">17.</a>	
<a href="#">2.</a>		<a href="#">18.</a>	
<a href="#">3.</a>		<a href="#">19.</a>	
<a href="#">4.</a>		<a href="#">20.</a>	
<a href="#">5.</a>		<a href="#">21.</a>	
<a href="#">6.</a>		<a href="#">22.</a>	
<a href="#">7.</a>		<a href="#">23.</a>	
<a href="#">8.</a>		<a href="#">24.</a>	
<a href="#">9.</a>		<a href="#">25.</a>	
<a href="#">10.</a>		<a href="#">26.</a>	
<a href="#">11.</a>		<a href="#">27.</a>	
<a href="#">12.</a>		<a href="#">28.</a>	
<a href="#">13.</a>		<a href="#">29.</a>	
<a href="#">14.</a>		<a href="#">30.</a>	
<a href="#">15.</a>		<a href="#">31.</a>	
<a href="#">16.</a>		<a href="#">32.</a>	

[<< 1-32 | 33-64 | 65-96 | 97-100 >>](#)
[Next >>](#)

- Set to Factory Default** Clear all profiles.
- Click the number under Index column for setting in detail.

Objects Setting >> Keyword Object Setup

Profile Index : 1

Name	<input type="text"/>
Contents	<input type="text"/>

**Name**

Type a name for this profile, e.g., game.

**Contents**

Type the content for such profile. For example, type *gambling* as Contents. When you browse the webpage, the page with gambling information will be watched out and be passed/blocked based on the configuration on Firewall settings.

### 3.4.6 Keyword Group

This page allows you to bind several keyword objects into one group. The keyword groups set here will be chosen as black /white list in **Anti-Spam >>Profile Setting**.

Objects Setting >> Keyword Group

Keyword Group Table:

[Set to Factory Default](#)

Index	Name	Index	Name
1.		9.	
2.		10.	
3.		11.	
4.		12.	
5.		13.	
6.		14.	
7.		15.	
8.		16.	

**Set to Factory Default**

Clear all profiles.

Click the number under Index column for setting in detail.

Objects Setting >> Keyword Group Setup

Profile Index : 1

Name:	<input type="text"/>
<b>Available Keyword Objects</b>	<b>Selected Keyword Objects(Max 8 Objects)</b>
<input type="text" value="1-Keyword-1"/> <input type="text" value="2-keyword-2"/>	<input type="text"/>
<input type="button" value="»"/>	<input type="button" value="«"/>

**Name**

Type a name for this group.

**Available Keyword Objects**

You can gather keyword objects from Keyword Object page within one keyword group. All the available Keyword objects that you have created will be shown in this box.

**Selected Keyword Objects**

Click  button to add the selected Keyword objects in this box.

### 3.4.7 File Extension Object

This page allows you to set eight profiles which will be applied in **CSM>>URL Content Filter** and **Defense Configuration>>Anti-Virus**. All the files with the extension names specified in these profiles will be processed according to the chosen action.

Profile 1 with name of “default” is the default profile, some files with the file extensions specified in this profile will be ignored and not be scanned by Vigor router.

**Objects Setting >> File Extension Object**

File Extension Object Profiles: **| Set to Factory Default |**

Profile	Name	Profile	Name
<u>1.</u>	default	<u>5.</u>	
<u>2.</u>		<u>6.</u>	
<u>3.</u>		<u>7.</u>	
<u>4.</u>		<u>8.</u>	

**Set to Factory Default**

Clear all profiles.

Click the number under Profile column for configuration in details.

Objects Setting >> File Extension Object Setup

Profile Index: 1      Profile Name:

Categories	File Extensions
<b>Image</b> <input type="button" value="Select All"/> <input type="button" value="Clear All"/>	<input checked="" type="checkbox"/> .bmp <input checked="" type="checkbox"/> .dib <input checked="" type="checkbox"/> .gif <input checked="" type="checkbox"/> .jpeg <input checked="" type="checkbox"/> .jpg <input checked="" type="checkbox"/> .jpg2 <input checked="" type="checkbox"/> .jp2 <input checked="" type="checkbox"/> .pct <input checked="" type="checkbox"/> .pcx <input checked="" type="checkbox"/> .pic <input checked="" type="checkbox"/> .pict <input checked="" type="checkbox"/> .png <input checked="" type="checkbox"/> .tif <input checked="" type="checkbox"/> .tiff
<b>Video</b> <input type="button" value="Select All"/> <input type="button" value="Clear All"/>	<input checked="" type="checkbox"/> .asf <input checked="" type="checkbox"/> .avi <input checked="" type="checkbox"/> .mov <input checked="" type="checkbox"/> .mpe <input checked="" type="checkbox"/> .mpeg <input checked="" type="checkbox"/> .mpg <input checked="" type="checkbox"/> .mp4 <input checked="" type="checkbox"/> .qt <input checked="" type="checkbox"/> .rm <input checked="" type="checkbox"/> .wmv <input checked="" type="checkbox"/> .3gp <input checked="" type="checkbox"/> .3gpp <input checked="" type="checkbox"/> .3gpp2 <input checked="" type="checkbox"/> .3g2
<b>Audio</b> <input type="button" value="Select All"/> <input type="button" value="Clear All"/>	<input checked="" type="checkbox"/> .aac <input checked="" type="checkbox"/> .aiff <input checked="" type="checkbox"/> .au <input checked="" type="checkbox"/> .mp3 <input checked="" type="checkbox"/> .m4a <input checked="" type="checkbox"/> .m4p <input checked="" type="checkbox"/> .ogg <input checked="" type="checkbox"/> .ra <input checked="" type="checkbox"/> .ram <input checked="" type="checkbox"/> .vox <input checked="" type="checkbox"/> .wav <input checked="" type="checkbox"/> .wma
<b>Java</b> <input type="button" value="Select All"/> <input type="button" value="Clear All"/>	<input type="checkbox"/> .class <input type="checkbox"/> .jad <input type="checkbox"/> .jar <input type="checkbox"/> .jav <input type="checkbox"/> .java <input type="checkbox"/> .jcm <input type="checkbox"/> .js <input type="checkbox"/> .jse <input type="checkbox"/> .jsp <input type="checkbox"/> .jtk
<b>ActiveX</b> <input type="button" value="Select All"/> <input type="button" value="Clear All"/>	<input type="checkbox"/> .alx <input type="checkbox"/> .apb <input type="checkbox"/> .axs <input type="checkbox"/> .ocx <input type="checkbox"/> .olb <input type="checkbox"/> .ole <input type="checkbox"/> .tlb <input type="checkbox"/> .viv <input type="checkbox"/> .vrm
<b>Compression</b> <input type="button" value="Select All"/> <input type="button" value="Clear All"/>	<input type="checkbox"/> .ace <input type="checkbox"/> .arj <input type="checkbox"/> .bzip2 <input type="checkbox"/> .bz2 <input type="checkbox"/> .cab <input type="checkbox"/> .gz <input type="checkbox"/> .gzip <input type="checkbox"/> .rar <input type="checkbox"/> .sit <input type="checkbox"/> .zip
<b>Execution</b> <input type="button" value="Select All"/> <input type="button" value="Clear All"/>	<input type="checkbox"/> .bas <input type="checkbox"/> .bat <input type="checkbox"/> .com <input type="checkbox"/> .exe <input type="checkbox"/> .inf <input type="checkbox"/> .pif <input type="checkbox"/> .reg <input type="checkbox"/> .scr

**Profile Name**      Type a name for this profile.

Type a name for such profile and check all the items of file extension that will be processed in the router. Finally, click **OK** to save this profile.



### 3.4.8 IM Object

This page allows you to set 32 profiles for Instant Messenger. These profiles will be applied in **Firewall>>IM/P2P Filter Profile** for filtering.

Objects Setting >> CSM-IM Object Profile

CSM-IM Profile Table:

| [Set to Factory Default](#) |

Profile	Name	Profile	Name
<u>1.</u>		<u>17.</u>	
<u>2.</u>		<u>18.</u>	
<u>3.</u>		<u>19.</u>	
<u>4.</u>		<u>20.</u>	
<u>5.</u>		<u>21.</u>	
<u>6.</u>		<u>22.</u>	
<u>7.</u>		<u>23.</u>	
<u>8.</u>		<u>24.</u>	
<u>9.</u>		<u>25.</u>	
<u>10.</u>		<u>26.</u>	
<u>11.</u>		<u>27.</u>	
<u>12.</u>		<u>28.</u>	
<u>13.</u>		<u>29.</u>	
<u>14.</u>		<u>30.</u>	
<u>15.</u>		<u>31.</u>	
<u>16.</u>		<u>32.</u>	

**Set to Factory Default**      Clear all profiles.

Click the number under Profile column for configuration in details. There are several types of Instant Messenger (IM) provided here for you to choose to disallow people using. Simple check the box (es) and then click **OK**. Later, in the **CSM>>IM/P2P Filter Profile** page, you can use **IM Object** drop down list to choose the proper profile configured here as the standard for the host(s) to follow.

Objects Setting >> CSM-IM Object Profile

**Profile Index: 1**

Profile Name:

**Check for Disallow:**

Advanced Management				
Activity / Application	MSN	YahooIM	AIM(<=5.9)	ICQ
Login	<input type="checkbox"/>	<input type="checkbox"/>	<input type="checkbox"/>	<input type="checkbox"/>
Message	<input type="checkbox"/>	<input type="checkbox"/>	<input type="checkbox"/>	<input type="checkbox"/>
File Transfer	<input type="checkbox"/>	<input type="checkbox"/>	<input type="checkbox"/>	<input type="checkbox"/>
Game	<input type="checkbox"/>	<input type="checkbox"/>	<input type="checkbox"/>	<input type="checkbox"/>
Video	<input type="checkbox"/>	<input type="checkbox"/>	<input type="checkbox"/>	<input type="checkbox"/>
Voice	<input type="checkbox"/>	<input type="checkbox"/>	<input type="checkbox"/>	<input type="checkbox"/>
Conference	<input type="checkbox"/>	<input type="checkbox"/>	<input type="checkbox"/>	<input type="checkbox"/>
Other Activities	<input type="checkbox"/>	<input type="checkbox"/>	<input type="checkbox"/>	<input type="checkbox"/>

Other IM Application				VoIP
<input type="checkbox"/> AIM6	<input type="checkbox"/> QQ	<input type="checkbox"/> iChat	<input type="checkbox"/> Jabber/GoogleTalk	<input type="checkbox"/> Skype
<input type="checkbox"/> GoogleChat	<input type="checkbox"/> XFire	<input type="checkbox"/> GaduGadu	<input type="checkbox"/> Paltalk	<input type="checkbox"/> SIP
<input type="checkbox"/> Qnext	<input type="checkbox"/> Meetro	<input type="checkbox"/> POCO/PP365	<input type="checkbox"/> AresChat	

Web IM ( * = more than one address)					
<input type="checkbox"/> WebIM URLs	<b><u>eMessenger</u></b>	<b><u>WebMSN</u></b>	<b><u>meebo*</u></b>	<b><u>eBuddy</u></b>	<b><u>ILoveIM*</u></b>
	<b><u>ICQ Java*</u></b>	<b><u>ICQ Flash*</u></b>	<b><u>goowy*</u></b>	<b><u>IMhaha*</u></b>	<b><u>getMessenger</u></b>
	<b><u>IMUnitive*</u></b>	<b><u>WabJet*</u></b>	<b><u>mabber*</u></b>	<b><u>MSN2GO*</u></b>	<b><u>KoolIM</u></b>
	<b><u>MessengerFX*</u></b>	<b><u>MessengerAdictos</u></b>	<b><u>WebYahooIM</u></b>		

**Profile Name**                      Type a name for this profile.

Type a name for such profile and check all the items that not allowed to be used in the host. Finally, click **OK** to save this profile.

### 3.4.9 P2P Object

This page allows you to set 32 profiles for peer-to-peer application. These profiles will be applied in **Firewall>>IM/P2P Filter Profile** for filtering.

Objects Setting >> CSM-P2P Object Profile

CSM-P2P Profile Table: | [Set to Factory Default](#) |

Profile	Name	Profile	Name
<a href="#">1.</a>		<a href="#">17.</a>	
<a href="#">2.</a>		<a href="#">18.</a>	
<a href="#">3.</a>		<a href="#">19.</a>	
<a href="#">4.</a>		<a href="#">20.</a>	
<a href="#">5.</a>		<a href="#">21.</a>	
<a href="#">6.</a>		<a href="#">22.</a>	
<a href="#">7.</a>		<a href="#">23.</a>	
<a href="#">8.</a>		<a href="#">24.</a>	
<a href="#">9.</a>		<a href="#">25.</a>	
<a href="#">10.</a>		<a href="#">26.</a>	
<a href="#">11.</a>		<a href="#">27.</a>	
<a href="#">12.</a>		<a href="#">28.</a>	
<a href="#">13.</a>		<a href="#">29.</a>	
<a href="#">14.</a>		<a href="#">30.</a>	
<a href="#">15.</a>		<a href="#">31.</a>	
<a href="#">16.</a>		<a href="#">32.</a>	

**Set to Factory Default**      Clear all profiles.

Click the number under Profile column for configuration in details. There are several items for P2P protocols provided here for you to choose to disallow people using. Simple check the box (es) and then click **OK**. Later, in the **CSM>>IM/P2P Filter Profile** page, you can use **P2P Object** drop down list to choose the proper profile configured here as the standard for the host(s) to follow.

Objects Setting >> CSM-P2P Object Profile

---

**Profile Index: 1**

Profile Name:

**Check for Disallow:**

Protocol	Applications
<input type="checkbox"/> SoulSeek	SoulSeek
<input type="checkbox"/> eDonkey	eDonkey, eMule, Shareaza
<input type="checkbox"/> FastTrack	KazaA, iMesh
<input type="checkbox"/> OpenFT	KCeasy, FilePipe
<input type="checkbox"/> Gnutella	BearShare, Limewire, Shareaza, Foxy
<input type="checkbox"/> OpenNap	Lopster, Xnap, WinLop
<input type="checkbox"/> BitTorrent	BitTorrent, BitSpirit, BitComet
<input type="checkbox"/> Winny	Winny, WinMX, Share

Other P2P Applications			
<input type="checkbox"/> Xunlei	<input type="checkbox"/> Vagaa	<input type="checkbox"/> PP365	<input type="checkbox"/> POCO
<input type="checkbox"/> Clubbox	<input type="checkbox"/> Ares		

**Profile Name**                      Type a name for this profile.

Type a name for such profile and check all the protocols that not allowed to be used in the host. Finally, click **OK** to save this profile.

### 3.4.10 Misc Object

This page allows you to set 32 profiles for miscellaneous applications. These profiles will be applied in **Firewall>>IM/P2P Filter Profile** for filtering.

Objects Setting >> CSM-Misc Object Profile

CSM-Misc Profile Table: | [Set to Factory Default](#) |

Profile	Name	Profile	Name
<a href="#">1.</a>		<a href="#">17.</a>	
<a href="#">2.</a>		<a href="#">18.</a>	
<a href="#">3.</a>		<a href="#">19.</a>	
<a href="#">4.</a>		<a href="#">20.</a>	
<a href="#">5.</a>		<a href="#">21.</a>	
<a href="#">6.</a>		<a href="#">22.</a>	
<a href="#">7.</a>		<a href="#">23.</a>	
<a href="#">8.</a>		<a href="#">24.</a>	
<a href="#">9.</a>		<a href="#">25.</a>	
<a href="#">10.</a>		<a href="#">26.</a>	
<a href="#">11.</a>		<a href="#">27.</a>	
<a href="#">12.</a>		<a href="#">28.</a>	
<a href="#">13.</a>		<a href="#">29.</a>	
<a href="#">14.</a>		<a href="#">30.</a>	
<a href="#">15.</a>		<a href="#">31.</a>	
<a href="#">16.</a>		<a href="#">32.</a>	

**Set to Factory Default** Clear all profiles.

Click the number under Profile column for configuration in details. Applications for tunneling and streaming are listed in the page for you to choose to disallow people using. Simple check the box (es) and then click **OK**. Later, in the **CSM>>IM/P2P Filter Profile** page, you can use **Misc Object** drop down list to choose the proper profile configured here as the standard for the host(s) to follow.

Objects Setting >> CSM-Misc Object Profile

Profile Index: 1

Profile Name:

Check for Disallow:

Tunneling				
<input type="checkbox"/> Socks4/5	<input type="checkbox"/> PGPNet	<input type="checkbox"/> HTTP Proxy	<input type="checkbox"/> TOR	<input type="checkbox"/> VNN
<input type="checkbox"/> SoftEther	<input type="checkbox"/> FolderShare	<input type="checkbox"/> MS TEREDO	<input type="checkbox"/> Wujie/UltraSurf	<input type="checkbox"/> Hamachi
<input type="checkbox"/> HTTP Tunnel	<input type="checkbox"/> Ping Tunnel	<input type="checkbox"/> TinyVPN		

Streaming			
<input type="checkbox"/> MMS	<input type="checkbox"/> RTSP	<input type="checkbox"/> TVAnts	<input type="checkbox"/> PPStream
<input type="checkbox"/> PPlive	<input type="checkbox"/> FeiDian	<input type="checkbox"/> UUSee	<input type="checkbox"/> NSPlayer
<input type="checkbox"/> PCAST	<input type="checkbox"/> TVKoo	<input type="checkbox"/> SopCast	<input type="checkbox"/> UDLiveX
<input type="checkbox"/> TVUPlayer	<input type="checkbox"/> MySee	<input type="checkbox"/> Joost	<input type="checkbox"/> FlashVideo

**Profile Name** Type a name for this profile.

Type a name for such profile and check all the protocols that not allowed to be used in the host. Finally, click **OK** to save this profile.

## 3.5 CSM Profile

### **Content Security Management (CSM)**

**CSM** is an abbreviation of **Content Security Management** which is used to control IM/P2P usage, filter the web content and URL content to reach a goal of security management.

#### **IM/P2P Filter**

As the popularity of all kinds of instant messenger application arises, communication cannot become much easier. Nevertheless, while some industry may leverage this as a great tool to connect with their customers, some industry may take reserve attitude in order to reduce employee misuse during office hour or prevent unknown security leak. It is similar situation for corporation towards peer-to-peer applications since file-sharing can be convenient but insecure at the same time. To address these needs, we provide CSM functionality.

#### **URL Content Filter**

To provide an appropriate cyberspace to users, Vigor router equips with **URL Content Filter** not only to limit illegal traffic from/to the inappropriate web sites but also prohibit other web feature where malicious code may conceal.

Once a user type in or click on an URL with objectionable keywords, URL keyword blocking facility will decline the HTTP request to that web page thus can limit user's access to the website. You may imagine **URL Content Filter** as a well-trained convenience-store clerk who won't sell adult magazines to teenagers. At office, **URL Content Filter** can also provide a job-related only environment hence to increase the employee work efficiency. How can URL Content Filter work better than traditional firewall in the field of filtering? Because it checks the URL strings or some of HTTP data hiding in the payload of TCP packets while legacy firewall inspects packets based on the fields of TCP/IP headers only.

On the other hand, Vigor router can prevent user from accidentally downloading malicious codes from web pages. It's very common that malicious codes conceal in the executable objects, such as ActiveX, Java Applet, compressed files, and other executable files. Once downloading these types of files from websites, you may risk bringing threat to your system. For example, an ActiveX control object is usually used for providing interactive web feature. If malicious code hides inside, it may occupy user's system.

#### **Web Content Filter**

We all know that the content on the Internet just like other types of media may be inappropriate sometimes. As a responsible parent or employer, you should protect those in your trust against the hazards. With Web filtering service of the Vigor router, you can protect your business from common primary threats, such as productivity, legal liability, network and security threats. For parents, you can protect your children from viewing adult websites or chat rooms.

Once you have activated your Web Filtering service in Vigor router and chosen the categories of website you wish to restrict, each URL address requested (e.g. www.bbc.co.uk) will be checked against our server database. This database is updated as frequent as daily by a global team of Internet researchers. The server will look up the URL and return a category to your router. Your Vigor router will then decide whether to allow access to this site according to the categories you have selected. Please note that this action will not introduce any delay in your

Web surfing because each of multiple load balanced database servers can handle millions of requests for categorization.

**Note:** The priority of URL Content Filter is higher than Web Content Filter.

- CSM
- ▶ IM/P2P Filter Profile
- ▶ URL Content Filter Profile
- ▶ Web Content Filter Profile

### 3.5.1 IM/P2P Filter Profile

You can define policy profiles for different policy of IM (Instant Messenger)/P2P (Peer to Peer) application. CSM profile can be used in Filter Setup page.

CSM >> IM/P2P Filter Profile

IM/P2P Filter Profile Table: | [Set to Factory Default](#) |

Profile	Name	Profile	Name
<a href="#">1.</a>		<a href="#">17.</a>	
<a href="#">2.</a>		<a href="#">18.</a>	
<a href="#">3.</a>		<a href="#">19.</a>	
<a href="#">4.</a>		<a href="#">20.</a>	
<a href="#">5.</a>		<a href="#">21.</a>	
<a href="#">6.</a>		<a href="#">22.</a>	
<a href="#">7.</a>		<a href="#">23.</a>	
<a href="#">8.</a>		<a href="#">24.</a>	
<a href="#">9.</a>		<a href="#">25.</a>	
<a href="#">10.</a>		<a href="#">26.</a>	
<a href="#">11.</a>		<a href="#">27.</a>	
<a href="#">12.</a>		<a href="#">28.</a>	
<a href="#">13.</a>		<a href="#">29.</a>	
<a href="#">14.</a>		<a href="#">30.</a>	
<a href="#">15.</a>		<a href="#">31.</a>	
<a href="#">16.</a>		<a href="#">32.</a>	

**Set to Factory Default**      Clear all profiles.

Click the number under Index column for settings in detail.

CSM >> IM/P2P Filter Profile

Profile Index: 1

Profile Name:

<b>IM Object</b>	None ▾
<b>P2P Object</b>	None ▾
<b>Misc Object</b>	None ▾

**Profile Name**      Type a name for the CSM profile.

Each profile can contain three objects settings, IM Object, P2P Object and Misc Object. Such profile can be applied in the **Firewall>>General Setup** and **Firewall>>Filter Setup** pages as the standard for the host(s) to follow.

### 3.5.2 URL Content Filter Profile

Based on the list of user defined keywords, the **URL Content Filter** facility in Vigor router inspects the URL string in every outgoing HTTP request. No matter the URL string is found full or partial matched with a keyword, the Vigor router will block the associated HTTP connection.

For example, if you add key words such as “sex”, Vigor router will limit web access to web sites or web pages such as “www.sex.com”, ”www.backdoor.net/images/sex/p\_386.html”. Or you may simply specify the full or partial URL such as “www.sex.com” or “sex.com”.

Also the Vigor router will discard any request that tries to retrieve the malicious code.

Click **CSM** and click **URL Content Filter** to open the profile setting page.

CSM >> URL Content Filter Profile

URL Content Filter Profile Table: | [Set to Factory Default](#) |

Profile	Name	Profile	Name
<u>1.</u>		<u>5.</u>	
<u>2.</u>		<u>6.</u>	
<u>3.</u>		<u>7.</u>	
<u>4.</u>		<u>8.</u>	

**Administration Message** (Max 255 characters)

```
<body><center><br><p>The requested Web page has been blocked by URL Content Filter.<p>Please contact your system administrator for further information.</center></body>
```

OK

You can set eight profiles as URL content filter. Simply click the index number under Profile to open the following web page.

CSM >> URL Content Filter Profile

**Profile Index: 1**

**Profile Name:**

**Priority:**  **Log:**

**1.URL Access Control**

Enable URL Access Control       Prevent web access from IP address

Action:       Group/Object Selections:

**2.Web Feature**

Enable Restrict Web Feature

Action:      Cookie     Proxy    **File Extension Profile:**

**Profile Name**                      Type the name for such profile.



## Priority

It determines the action that this router will apply.

**Both: Pass** – The router will let all the packages that match with the conditions specified in URL Access Control and Web Feature below passing through. When you choose this setting, both configuration set in this page for URL Access Control and Web Feature will be inactive.

**Both:Block** –The router will block all the packages that match with the conditions specified in URL Access Control and Web Feature below. When you choose this setting, both configuration set in this page for URL Access Control and Web Feature will be inactive.

**Either: URL Access Control First** – When all the packages matching with the conditions specified in URL Access Control and Web Feature below, such function can determine the priority for the actions executed. For this one, the router will process the packages with the conditions set below for URL first, then Web feature second.

**Either: Web Feature First** –When all the packages matching with the conditions specified in URL Access Control and Web Feature below, such function can determine the priority for the actions executed. For this one, the router will process the packages with the conditions set below for web feature first, then URL second.

**Priority:**

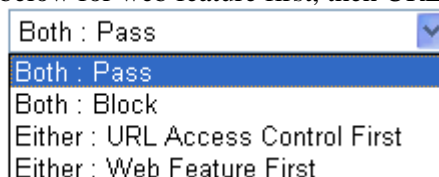

A screenshot of a web interface dropdown menu for the 'Priority' setting. The menu is open, showing five options: 'Both : Pass' (selected), 'Both : Block', 'Either : URL Access Control First', and 'Either : Web Feature First'. The selected option is highlighted in blue.

## Log

**None** – There is no log file will be recorded for this profile.

**Pass** – Only the log about Pass will be recorded in Syslog.

**Block** – Only the log about Block will be recorded in Syslog.

**All** – All the actions (Pass and Block) will be recorded in Syslog.

**Log:**

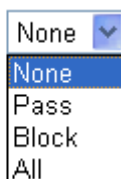

A screenshot of a web interface dropdown menu for the 'Log' setting. The menu is open, showing four options: 'None' (selected), 'Pass', 'Block', and 'All'. The selected option is highlighted in blue.

## URL Access Control

**Enable URL Access Control** - Check the box to activate URL Access Control. Note that the priority for **URL Access Control** is higher than **Restrict Web Feature**. If the web content match the setting set in URL Access Control, the router will execute the action specified in this field and ignore the action specified under Restrict Web Feature.

**Prevent web access from IP address** - Check the box to deny any web surfing activity using IP address, such as http://202.6.3.2. The reason for this is to prevent someone dodges the URL Access Control. You must clear your browser cache first so that the URL content filtering facility operates properly on a web page that you visited before.

**Action** – This setting is available only when **Either : URL Access Control First** or **Either : Web Feature First** is selected. **Pass** - Allow accessing into the corresponding webpage with the keywords listed on the box below.

**Block** - Restrict accessing into the corresponding webpage with the keywords listed on the box below.

If the web pages do not match with the keyword set here, it will be processed with reverse action.

Action:

Block
Pass
Block

**Group/Object Selections** – The Vigor router provides several frames for users to define keywords and each frame supports multiple keywords. The keyword could be a noun, a partial noun, or a complete URL string. Multiple keywords within a frame are separated by space, comma, or semicolon. In addition, the maximal length of each frame is 32-character long. After specifying keywords, the Vigor router will decline the connection request to the website whose URL string matched to any user-defined keyword. It should be noticed that the more simplified the blocking keyword list, the more efficiently the Vigor router perform.

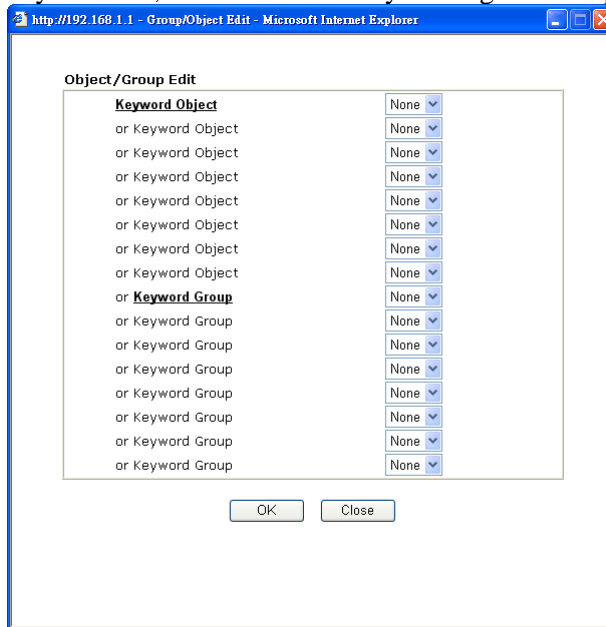

## Web Feature

**Enable Restrict Web Feature** - Check this box to make the keyword being blocked or passed.

**Action** - This setting is available only when **Either : URL Access Control First** or **Either : Web Feature Firs** is selected. **Pass** allows accessing into the corresponding webpage with the keywords listed on the box below.

**Pass** - Allow accessing into the corresponding webpage with the keywords listed on the box below.

**Block** - Restrict accessing into the corresponding webpage with the keywords listed on the box below.

If the web pages do not match with the specified feature set here, it will be processed with reverse action.

**Cookie** - Check the box to filter out the cookie transmission from

inside to outside world to protect the local user's privacy.

**Proxy** - Check the box to reject any proxy transmission. To control efficiently the limited-bandwidth usage, it will be of great value to provide the blocking mechanism that filters out the multimedia files downloading from web pages.

**File Extension Profile** – Choose one of the profiles that you configured in **Object Setting**>> **File Extension Objects** previously for passing or blocking the file downloading.

**File Extension Profile:**    

### 3.5.3 Web Content Filter Profile

Click **CSM** and click **Web Content Filter** to open the profile setting page.

CSM >> **Web Content Filter Profile**

---

**Web Content Filter Profile Table:** | [Set to Factory Default](#) |

Profile	Name	Profile	Name
<u>1.</u>		<u>5.</u>	
<u>2.</u>		<u>6.</u>	
<u>3.</u>		<u>7.</u>	
<u>4.</u>		<u>8.</u>	

**Web Content Filter Setup**

Select a server:  

**Test a site to verify whether it is categorized**

**Administration Message** (Max 255 characters)

```
<body><center><br><p><p>The requested Web page has been blocked by Web Content Filter.<p>Please contact your system administrator for further information.</center></body>
```

You can set eight profiles as Web content filter. Simply click the index number under Profile to open the following web page.

**Profile Index : 1**

Profile Name:

<b>Action :</b> <input type="button" value="Block"/>		<b>log :</b> <input type="button" value="Block"/>	
<b>Groups</b>	<b>Categories</b>		
Child Protection <input type="button" value="Select All"/> <input type="button" value="Clear All"/>	<input type="checkbox"/> Chat <input type="checkbox"/> Gambling <input type="checkbox"/> Sex	<input type="checkbox"/> Criminal <input type="checkbox"/> Hacking <input type="checkbox"/> Violence	<input type="checkbox"/> Drugs/Alcohol <input type="checkbox"/> Hate speech <input type="checkbox"/> Weapons
Leisure <input type="button" value="Select All"/> <input type="button" value="Clear All"/>	<input type="checkbox"/> Advertisements <input type="checkbox"/> Games <input type="checkbox"/> Hobbies <input type="checkbox"/> Personals <input type="checkbox"/> Sports	<input type="checkbox"/> Entertainment <input type="checkbox"/> Glamour <input type="checkbox"/> Lifestyle <input type="checkbox"/> Photo Searches <input type="checkbox"/> Streaming Media	<input type="checkbox"/> Food <input type="checkbox"/> Health <input type="checkbox"/> Motor Vehicles <input type="checkbox"/> Shopping <input type="checkbox"/> Travel
Business <input type="button" value="Select All"/> <input type="button" value="Clear All"/>	<input type="checkbox"/> Computing/Internet <input type="checkbox"/> Politics <input type="checkbox"/> Remote proxies	<input type="checkbox"/> Finance <input type="checkbox"/> Real Estate <input type="checkbox"/> Search Engine	<input type="checkbox"/> Job Search/Career <input type="checkbox"/> Reference <input type="checkbox"/> Web Mail
Others <input type="button" value="Select All"/> <input type="button" value="Clear All"/>	<input type="checkbox"/> Education <input type="checkbox"/> News <input type="checkbox"/> Usenet news	<input type="checkbox"/> Hosting sites <input type="checkbox"/> Religion <input type="checkbox"/> uncatagorised sites	<input type="checkbox"/> Kid Sites <input type="checkbox"/> Sex Education

**Action**

**Pass** - allow accessing into the corresponding webpage with the categories listed on the box below.

**Block** - restrict accessing into the corresponding webpage with the categories listed on the box below.

If the web pages do not match with the specified feature set here, it will be processed with reverse action.

**Log**

**None** – There is no log file will be recorded for this profile.

**Pass** – Only the log about Pass will be recorded in Syslog.

**Block** – Only the log about Block will be recorded in Syslog.

**All** – All the actions (Pass and Block) will be recorded in Syslog.

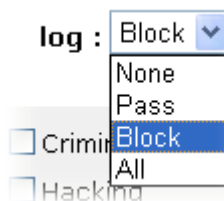

For this section, please refer to **Web Content Filter** user's guide.

## 3.6 Firewall

### 3.6.1 Basics for Firewall

While the broadband users demand more bandwidth for multimedia, interactive applications, or distance learning, security has been always the most concerned. The firewall of the Vigor router helps to protect your local network against attack from unauthorized outsiders. It also

restricts users in the local network from accessing the Internet. Furthermore, it can filter out specific packets that trigger the router to build an unwanted outgoing connection.

The most basic security concept is to set user name and password while you install your router. The administrator login will prevent unauthorized access to the router configuration from your router.

#### Quick Start Wizard

---

##### Enter login password

Please enter an alpha-numeric string as your **Password** (Max 23 characters).

New Password

Confirm Password

If you did not set password during installation; you can go to **System Maintenance** to set up your password.

#### System Maintenance >> Administrator Password Setup

---

##### Administrator Password

Old Password

New Password

Confirm Password

## Firewall Facilities

The users on the LAN are provided with secured protection by the following firewall facilities:

- User-configurable IP filter (Call Filter/ Data Filter).
- Stateful Packet Inspection (SPI): tracks packets and denies unsolicited incoming data
- Selectable Denial of Service (DoS) /Distributed DoS (DDoS) attacks protection
- URL Content Filter

## IP Filters

Depending on whether there is an existing Internet connection, or in other words “the WAN link status is up or down”, the IP filter architecture categorizes traffic into two: **Call Filter** and **Data Filter**.

- **Call Filter** - When there is no existing Internet connection, **Call Filter** is applied to all traffic, all of which should be outgoing. It will check packets according to the filter rules. If legal, the packet will pass. Then the router shall **“initiate a call”** to build the Internet connection and send the packet to Internet.
- **Data Filter** - When there is an existing Internet connection, **Data Filter** is applied to incoming and outgoing traffic. It will check packets according to the filter rules. If legal, the packet will pass the router.

The following illustrations are flow charts explaining how router will treat incoming traffic and outgoing traffic respectively.

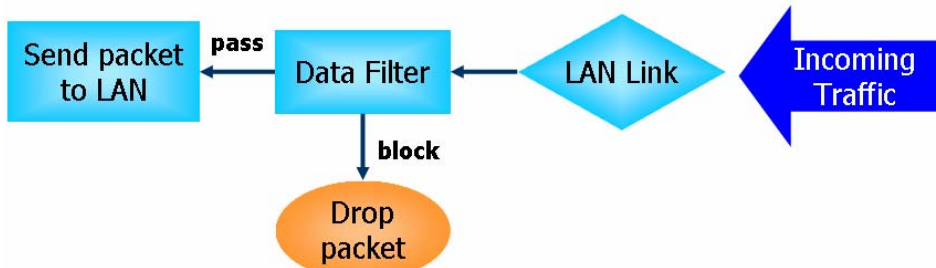
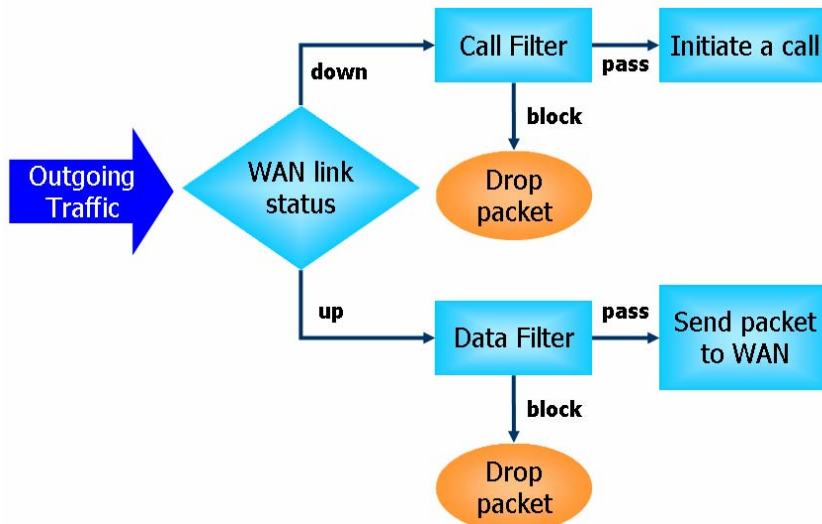

### Stateful Packet Inspection (SPI)

Stateful inspection is a firewall architecture that works at the network layer. Unlike legacy static packet filtering, which examines a packet based on the information in its header, stateful inspection builds up a state machine to track each connection traversing all interfaces of the firewall and makes sure they are valid. The stateful firewall of Vigor router not just examine the header information also monitor the state of the connection.

### Denial of Service (DoS) Defense

The **DoS Defense** functionality helps you to detect and mitigate the DoS attack. The attacks are usually categorized into two types, the flooding-type attacks and the vulnerability attacks. The flooding-type attacks will attempt to exhaust all your system's resource while the

vulnerability attacks will try to paralyze the system by offending the vulnerabilities of the protocol or operation system.

The **DoS Defense** function enables the Vigor router to inspect every incoming packet based on the attack signature database. Any malicious packet that might duplicate itself to paralyze the host in the secure LAN will be strictly blocked and a Syslog message will be sent as warning, if you set up Syslog server.

Also the Vigor router monitors the traffic. Any abnormal traffic flow violating the pre-defined parameter, such as the number of thresholds, is identified as an attack and the Vigor router will activate its defense mechanism to mitigate in a real-time manner.

The below shows the attack types that DoS/DDoS defense function can detect:

1. SYN flood attack
2. UDP flood attack
3. ICMP flood attack
4. TCP Flag scan
5. Trace route
6. IP options
7. Unknown protocol
8. Land attack
9. Smurf attack
10. SYN fragment
11. ICMP fragment
12. Tear drop attack
13. Fraggle attack
14. Ping of Death attack
15. TCP/UDP port scan

## Anti-Virus and Anti-Intrusion

Users might have much more confidence about the security in the network for data transmission if the functions of anti-virus and anti-intrusion are activated. The VigorPro router offers the mechanism of anti-virus and anti-intrusion. What you have to do is to set the proper profiles and invoke them. The anti-virus profile and anti-intrusion configuration can be set in Anti-Virus menu (refer to section 3.7) and Anti-Intrusion menu (refer to section 3.6). However, the mechanism must be enabled either in **Firewall>>General Setup** or **Firewall>>Filter Setup** web page. After you choose proper Anti-Virus profile and check Anti-Intrusion box, the Anti-Virus and Anti-Intrusion LEDs on the front panel will light up.

Below shows the menu items for Firewall.

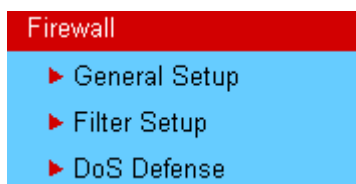

### 3.6.2 General Setup

General Setup allows you to adjust settings of IP Filter and common options. Here you can enable or disable the **Call Filter** or **Data Filter**. Under some circumstance, your filter set can be linked to work in a serial manner. So here you assign the **Start Filter Set** only. Also you can configure the **Log Flag** settings, **Apply IP filter to VPN incoming packets**, and **Accept incoming fragmented UDP packets**.

**Important:** When some packet does not fit the rule configured in **Filter Setup** web page, the filtering action configured in general setup web page will apply to that packet.

Click **Firewall** and click **General Setup** to open the general setup page.

**General Setup**

**Call Filter**  Enable  Disable Start Filter Set Set#1 ▼

**Data Filter**  Enable  Disable Start Filter Set Set#2 ▼

---

**Actions for default rule:**

Application	Action/Profile	Syslog
<b>Filter</b>	<span>Pass</span> ▼	<input type="checkbox"/>
<b>IM/P2P Filter</b>	<span>None</span> ▼	<input type="checkbox"/>
<b>URL Content Filter</b>	<span>None</span> ▼	<input type="checkbox"/>
<b>Web Content Filter</b>	<span>None</span> ▼	<input type="checkbox"/>
<b>Anti-Virus</b>	<span>None</span> ▼	<input type="checkbox"/>
<b>Anti-Intrusion</b>	<input type="checkbox"/> Enable	<input type="checkbox"/>
<b>Anti-Spam</b>	<span>None</span> ▼	<input type="checkbox"/>

---

Advance Setting Edit

---

Apply IP filter to VPN incoming packets

Accept large incoming fragmented UDP or ICMP packets ( for some games, ex. CS )

Enable Transparent mode

[Strict Security Checking](#)

Anti-Virus  Anti-Spam  In-Sequence

OK Cancel

**Call Filter** Check **Enable** to activate the Call Filter function. Assign a start filter set for the Call Filter.

**Data Filter** Check **Enable** to activate the Data Filter function. Assign a start filter set for the Data Filter.

**Filter** Select **Pass** or **Block** for the packets that do not match with the filter rules.

Filter Pass ▼

Pass

Block

**IM/P2P Filter** Select a CSM profile for global IM/P2P application blocking. All the hosts in LAN must follow the standard configured in the CSM profile selected here. For detailed information, refer to the section of CSM profile setup. For troubleshooting needs, you can specify to record information for IM/P2P by checking the Log box. It will be sent to Syslog server. Please refer to section 3.14.4 **Syslog/Mail Alert** for more detailed information.

**URL Content Filter** Select one of the **URL Content Filter** profile settings (created in **CSM>> URL Content Filter**) for applying with this router. Please set at least one profile for choosing in **CSM>> URL Content Filter** web page first. For troubleshooting needs, you can specify to record information for **URL Content Filter** by checking the Log box. It will be sent to Syslog server. Please refer to section 3.14.4 **Syslog/Mail Alert** for more detailed information.



<b>Web Content Filter</b>	Select one of the <b>Web Content Filter</b> profile settings (created in <b>CSM&gt;&gt; Web Content Filter</b> ) for applying with this router. Please set at least one profile for anti-virus in <b>CSM&gt;&gt; Web Content Filter</b> web page first. For troubleshooting needs, you can specify to record information for <b>Web Content Filter</b> by checking the Log box. It will be sent to Syslog server. Please refer to section 3.14.4 <b>Syslog/Mail Alert</b> for more detailed information.
<b>Anti-Virus</b>	Select one of the anti-virus profile settings (created in <b>Anti-Virus&gt;&gt;Profile Setting</b> ) for applying with this router. Please set at least one profile for anti-virus in <b>Anti-Virus-&gt; Profile Setting</b> web page first. For troubleshooting needs, you can specify to record information for <b>Anti-Virus</b> by checking the Log box. It will be sent to Syslog server. Please refer to section 3.14.4 <b>Syslog/Mail Alert</b> for more detailed information.
<b>Anti-Intrusion</b>	Check the <b>Enable</b> box to invoke anti-intrusion filter function. For troubleshooting needs, you can specify to record information for <b>Anti-Intrusion</b> by checking the Log box. It will be sent to Syslog server. Please refer to section 3.14.4 <b>Syslog/Mail Alert</b> for more detailed information.
<b>Anti-Spam</b>	Select one of the anti-spam profile settings (created in <b>Anti-Spam&gt;&gt;Profile Setting</b> ) for applying with this router. Please set at least one profile for anti-spam in <b>Anti-Spam&gt;&gt;Profile Setting</b> web page first. For troubleshooting needs, you can specify to record information for <b>Anti-Spam</b> by checking the Log box. It will be sent to Syslog server. Please refer to section 3.14.4 <b>Syslog/Mail Alert</b> for more detailed information.
<b>Apply IP filter to VPN incoming packets</b>	Check this box to enable the function.
<b>Accept large incoming...</b>	Some on-line games (for example: Half Life) will use lots of fragmented UDP packets to transfer game data. Instinctively as a secure firewall, Vigor router will reject these fragmented packets to prevent attack unless you enable “ <b>Accept large incoming fragmented UDP or ICMP Packets</b> ”. By checking this box, you can play these kinds of on-line games. If security concern is in higher priority, you cannot enable “ <b>Accept large incoming fragmented UDP or ICMP Packets</b> ”.
<b>Enable Transparent Mode</b>	Check this box to enable transparent function for such router. It is not necessary for users to re-organize the network or configure the subnet settings for each PC connected under such router. However, the configured Anti-Virus, Anti-Intrusion and Anti-Spam profiles can be applied to PCs connected behind vigor router to have the best security. The following picture explains the basic structure for using transparent mode for vigor router.

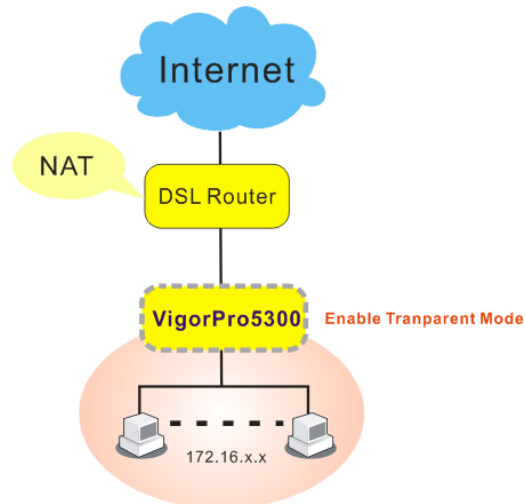

PCs with subnet “172.16.x.x” connected under VigorPro 5300 will be protected by security settings enabled and configured on the web pages of Vigor router. When the transparent mode has been checked, hackers from Internet do not sense the existence of vigor router, therefore they cannot attack the router.

### Advance Setting

Click **Edit** to open the following window. However, it is **strongly recommended** to use the default settings here.

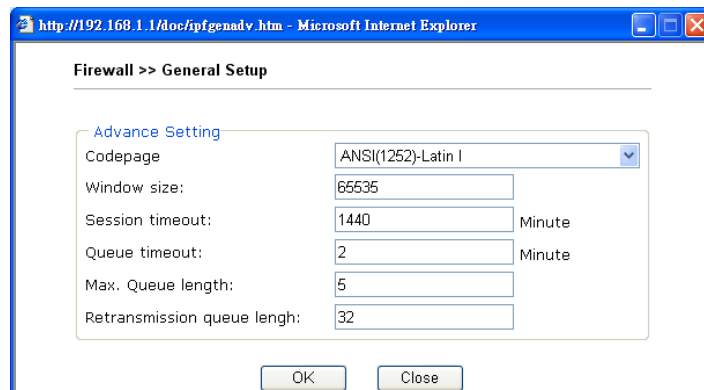

**Codepage** - This function is used to compare the characters among different languages. Choose correct codepage can help the system obtaining correct ASCII after decoding data from URL and enhance the correctness of URL Content Filter. The default value for this setting is ANSI 1252 Latin I. If you do not choose any codepage, no decoding job of URL will be processed. Please use the drop-down list to choose a codepage. If you do not have any idea of choosing suitable codepage, please open Syslog. From Codepage Information of Setup dialog, you will see the recommended codepage listed on the dialog box.

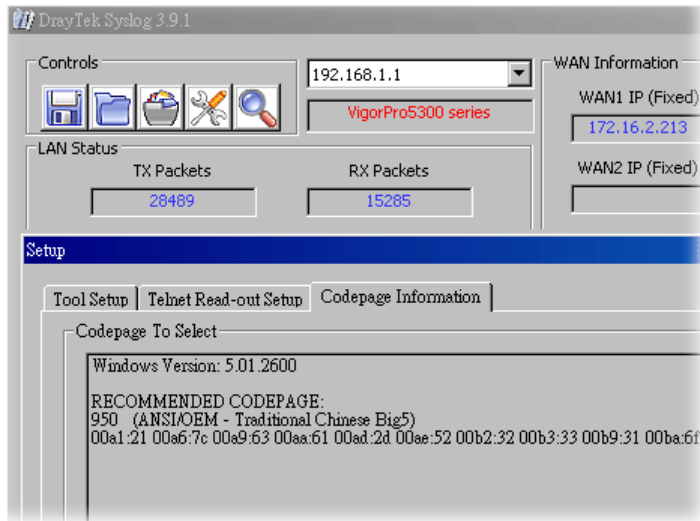

**Window size** – It determines the size of TCP protocol (0~65535). The more the value is, the better the performance will be. However, if the network is not stable, small value will be proper.

**Session timeout /Queue timeout**–Setting timeout for sessions can make the best utilization of network resources. However, Queue timeout is configured for TCP protocol only; session timeout is configured for the data flow which matched with the firewall rule.

**Max. Queue length** - When the network connection is not stable, you can set large number for this setting to get better performance. Yet large value will consume large resource.

**Retransmission queue length** – Type the number here as a base for the router to verify if the retransmitted data is the same as the old one.

## Strict Security Checking

For the sake of security, you might want the router executing strict security checking for data transmission. The router performance will be affected if you invoke strict security checking.

**Anti-Virus** – Check this box to execute the critical checking for virus.

**Anti-Spam** – Check this box to execute the critical checking for e-mails.

**In sequence** – Check this box to execute the critical checking for all the files in sequence.

### 3.6.3 Filter Setup

Click **Firewall** and click **Filter Setup** to open the setup page.

Firewall >> Filter Setup

Filter Setup		<a href="#">Set to Factory Default</a>	
Set	Comments	Set	Comments
<a href="#">1.</a>	Default Call Filter	<a href="#">7.</a>	
<a href="#">2.</a>	Default Data Filter	<a href="#">8.</a>	
<a href="#">3.</a>		<a href="#">9.</a>	
<a href="#">4.</a>		<a href="#">10.</a>	
<a href="#">5.</a>		<a href="#">11.</a>	
<a href="#">6.</a>		<a href="#">12.</a>	

To edit or add a filter, click on the set number to edit the individual set. The following page will be shown. Each filter set contains up to 7 rules. Click on the rule number button to edit each rule. Check **Active** to enable the rule.

Firewall >> Filter Setup >> Edit Filter Set

**Filter Set 1**  
 Comments :

Filter Rule	Active	Comments	Move Up	Move Down
<input type="button" value="1"/>	<input checked="" type="checkbox"/>	Block NetBios		<a href="#">Down</a>
<input type="button" value="2"/>	<input type="checkbox"/>		<a href="#">UP</a>	<a href="#">Down</a>
<input type="button" value="3"/>	<input type="checkbox"/>		<a href="#">UP</a>	<a href="#">Down</a>
<input type="button" value="4"/>	<input type="checkbox"/>		<a href="#">UP</a>	<a href="#">Down</a>
<input type="button" value="5"/>	<input type="checkbox"/>		<a href="#">UP</a>	<a href="#">Down</a>
<input type="button" value="6"/>	<input type="checkbox"/>		<a href="#">UP</a>	<a href="#">Down</a>
<input type="button" value="7"/>	<input type="checkbox"/>		<a href="#">UP</a>	

Next Filter Set

**Filter Rule** Click a button numbered (1 ~ 7) to edit the filter rule. Click the button will open Edit Filter Rule web page. For the detailed information, refer to the following page.

**Active** Enable or disable the filter rule.

**Comment** Enter filter set comments/description. Maximum length is 23-character long.

**Move Up/Down** Use **Up** or **Down** link to move the order of the filter rules.

**Next Filter Set** Set the link to the next filter set to be executed after the current filter run. Do not make a loop with many filter sets.

To edit **Filter Rule**, click the **Filter Rule** index button to enter the **Filter Rule** setup page.

Filter Set 1 Rule 1

Check to enable the Filter Rule

Comments:

Index(1-15) in **Schedule** Setup:  ,  ,  ,

---

Direction:

Source IP:

Destination IP:

Service Type:

Fragments:

---

Application	Action/Profile	Syslog
Filter:	<input type="text" value="Block Immediately"/>	<input type="checkbox"/>
Branch to Other Filter Set:	<input type="text" value="None"/>	
<b>IM/P2P Filter:</b>	<input type="text" value="None"/>	<input type="checkbox"/>
<b>URL Content Filter</b>	<input type="text" value="None"/>	<input type="checkbox"/>
<b>Web Content Filter</b>	<input type="text" value="None"/>	<input type="checkbox"/>
<b>Anti-Virus:</b>	<input type="text" value="None"/>	<input type="checkbox"/>
<b>Anti-Intrusion:</b>	<input type="checkbox"/> Enable	<input type="checkbox"/>
<b>Anti-Spam:</b>	<input type="text" value="None"/>	<input type="checkbox"/>

---

Advance Setting

**Check to enable the Filter Rule**

Check this box to enable the filter rule.

**Comments**

Enter filter set comments/description. Maximum length is 14-character long.

**Index (1-15)**

Set PCs on LAN to work at certain time interval only. You may choose up to 4 schedules out of the 15 schedules pre-defined in **Applications >> Schedule** setup. The default setting of this field is blank and the function will always work.

**Direction**

Set the direction of packet flow (LAN->WAN/WAN->LAN). It is for **Data Filter** only. For the **Call Filter**, this setting is not available since **Call Filter** is only applied to outgoing traffic.

**Source/Destination IP**

Click **Edit** to access into the following dialog to choose the source/destination IP or IP ranges.

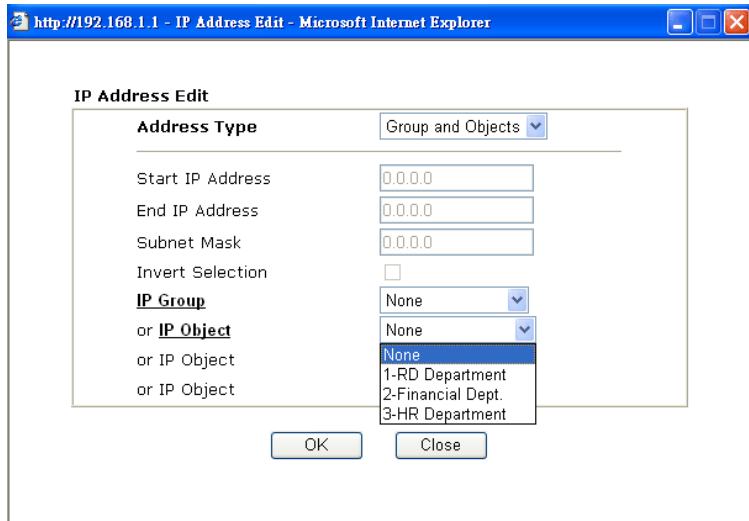

To set the IP address manually, please choose **Any Address/Single Address/Range Address/Subnet Address** as the Address Type and type them in this dialog. In addition, if you want to use the IP range from defined groups or objects, please choose **Group and Objects** as the Address Type.

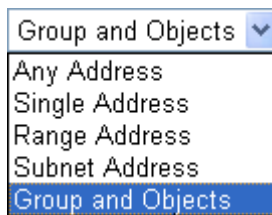

From the **IP Group** drop down list, choose the one that you want to apply. Or use the **IP Object** drop down list to choose the object that you want.

## Service Type

Click **Edit** to access into the following dialog to choose a suitable service type.

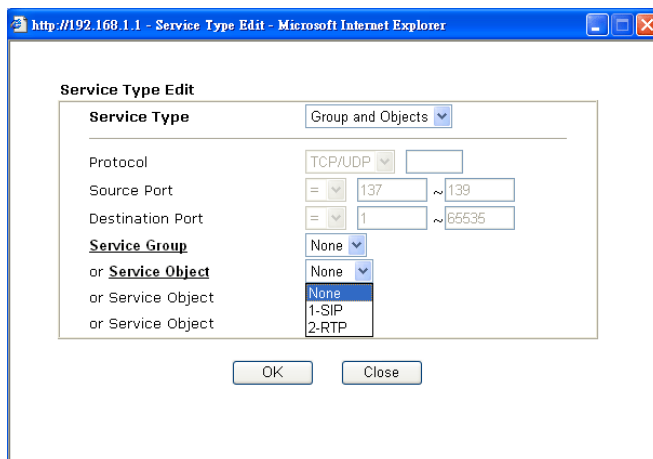

To set the service type manually, please choose **User defined** as the Service Type and type them in this dialog. In addition, if you want to use the service type from defined groups or objects, please

choose **Group and Objects** as the Service Type.

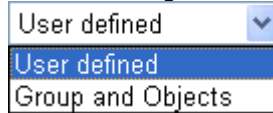

**Protocol** - Specify the protocol(s) which this filter rule will apply to.  
**Source/Destination Port** -

(=) – when the first and last value are the same, it indicates one port; when the first and last values are different, it indicates a range for the port and available for this service type.

(!=) – when the first and last value are the same, it indicates all the ports except the port defined here; when the first and last values are different, it indicates that all the ports except the range defined here are available for this service type.

(>) – the port number greater than this value is available.

(<) – the port number less than this value is available for this profile.

**Service Group/Object** - Use the drop down list to choose the one that you want.

#### **Fragments**

Specify the action for fragmented packets. And it is used for **Data Filter** only.

**Don't care** -No action will be taken towards fragmented packets.

**Unfragmented** -Apply the rule to unfragmented packets.

**Fragmented** - Apply the rule to fragmented packets.

**Too Short** - Apply the rule only to packets that are too short to contain a complete header.

#### **Filter**

Specifies the action to be taken when packets match the rule.

**Block Immediately** - Packets matching the rule will be dropped immediately.

**Pass Immediately** - Packets matching the rule will be passed immediately.

**Block If No Further Match** - A packet matching the rule, and that does not match further rules, will be dropped.

**Pass If No Further Match** - A packet matching the rule, and that does not match further rules, will be passed through.

#### **Branch to other Filter Set**

If the packet matches the filter rule, the next filter rule will branch to the specified filter set. Select next filter rule to branch from the drop-down menu. Be aware that the router will apply the specified filter rule for ever and will not return to previous filter rule any more.

#### **IM/P2P Filter**

Select a CSM profile for global IM/P2P application blocking. All the hosts in LAN must follow the standard configured in the CSM profile selected here. For detailed information, refer to the section of CSM profile setup. For troubleshooting needs, you can specify to record information for IM/P2P by checking the Log box. It will be sent to Syslog server. Please refer to section 3.14.4 **Syslog/Mail Alert** for more detailed information.

#### **URL Content Filter**

Select one of the **URL Content Filter** profile settings (created in **CSM>> URL Content Filter Profile**) for applying with this router. Please set at least one profile for choosing in **CSM>> URL Content Filter Profile** web page first. For troubleshooting needs, you can specify to record information for **URL Content Filter** by

checking the Log box. It will be sent to Syslog server. Please refer to section 3.14.4 **Syslog/Mail Alert** for more detailed information.

### Web Content Filter

Select one of the **Web Content Filter** profile settings (created in **CSM>> Web Content Filter Profile**) for applying with this router. Please set at least one profile for anti-virus in **CSM>> Web Content Filter Profile** web page first. For troubleshooting needs, you can specify to record information for **Web Content Filter** by checking the Log box. It will be sent to Syslog server. Please refer to section 3.14.4 **Syslog/Mail Alert** for more detailed information.

### Anti-Virus

Select one of the anti-virus profile settings (created in **Defense Configuration>>Anti-Virus>>Profile Setting**) for applying with this router. Please set at least one profile for anti-virus in **Defense Configuration>>Anti-Virus-> Profile Setting** web page first. For troubleshooting needs, you can specify to record information for **Anti-Virus** by checking the Log box. It will be sent to Syslog server. Please refer to section 3.14.4 **Syslog/Mail Alert** for more detailed information.

### Anti-Intrusion

Check the **Enable** box to invoke anti-intrusion filter function. For troubleshooting needs, you can specify to record information for **Anti-Intrusion** by checking the Log box. It will be sent to Syslog server. Please refer to section 3.14.4 **Syslog/Mail Alert** for more detailed information.

### Anti-Spam

Select one of the anti-spam profile settings (created in **Defense Configuration>>Anti-Spam>>Profile Setting**) for applying with this router. Please set at least one profile for anti-spam in **Defense Configuration>>Anti-Spam>>Profile Setting** web page first. For troubleshooting needs, you can specify to record information for **Anti-Spam** by checking the Log box. It will be sent to Syslog server. Please refer to section 3.14.4 **Syslog/Mail Alert** for more detailed information.

### Advance Setting

Click **Edit** to open the following window. Click **Edit** to open the following window. However, it is **strongly recommended** to use the default settings here.

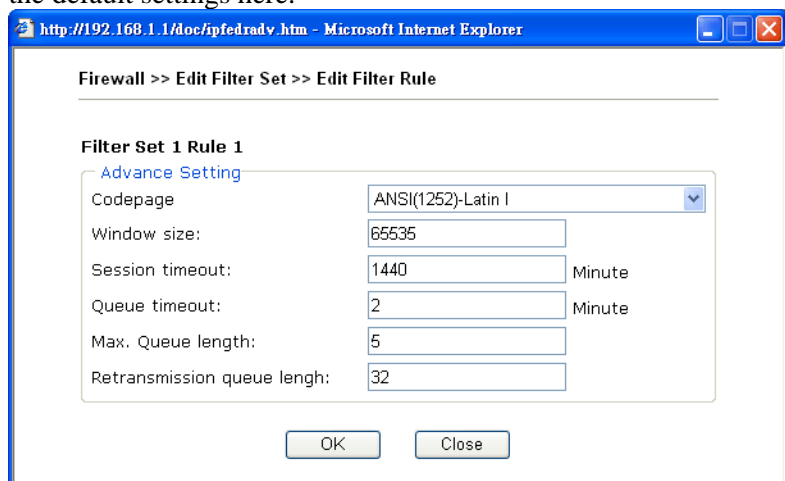

**Codepage** - This function is used to compare the characters among different languages. Choose correct codepage can help the system obtaining correct ASCII after decoding from URL and enhance the correctness of URL Content Filter. The default value for this setting is ANSI 1252 Latin I. If you do not choose any



codepage, no decoding job of URL will be processed. Please use the drop-down list to choose a codepage.

If you do not have any idea of choosing suitable codepage, please open Syslog. From Codepage Information of Setup dialog, you will see the recommended codepage listed on the dialog box.

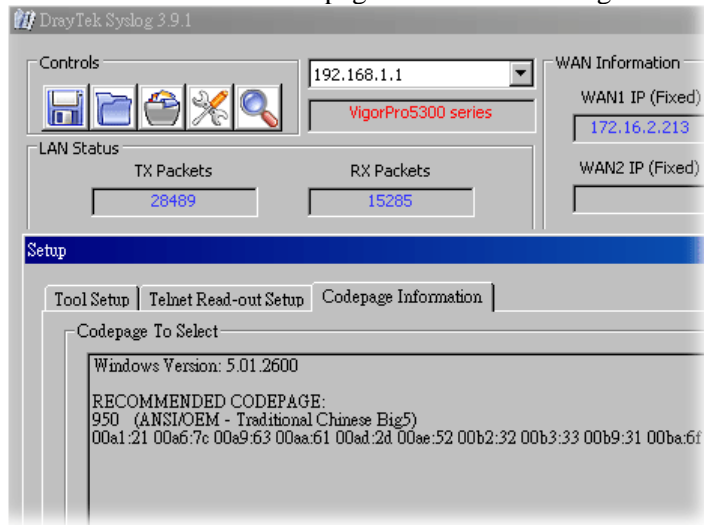

**Window size** – It determines the size of TCP protocol (0~65535). The more the value is, the better the performance will be. However, if the network is not stable, small value will be proper.

**Session timeout /Queue timeout**–Setting timeout for sessions can make the best utilization of network resources. However, Queue timeout is configured for TCP protocol only; session timeout is configured for the data flow which matched with the firewall rule.

**Max. Queue length** - When the network connection is not stable, you can set large number for this setting to get better performance. Yet large value will consume large resource.

**Retransmission queue length** – Type the number here as a base for the router to verify if the retransmitted data is the same as the old one.

## Example

As stated before, all the traffic will be separated and arbitrated using on of two IP filters: call filter or data filter. You may preset 12 call filters and data filters in **Filter Setup** and even link them in a serial manner. Each filter set is composed by 7 filter rules, which can be further defined. After that, in **General Setup** you may specify one set for call filter and one set for data filter to execute first.

**General Setup**

Call Filter  Enable  Disable Start Filter Set: Set#1

Data Filter  Enable  Disable Start Filter Set: Set#2

**Actions for default rule:**

Application	Action/Profile	Syslog
Filter	Pass	<input type="checkbox"/>
Codepage	None	<input type="checkbox"/>
IM/P2P	None	<input type="checkbox"/>
URL Content Filter	None	<input type="checkbox"/>
Web Content Filter	None	<input type="checkbox"/>
Anti-Virus	None	<input type="checkbox"/>
Anti-Intrusion	<input type="checkbox"/> Enable	<input type="checkbox"/>
Anti-Spam	None	<input type="checkbox"/>

Accept large incoming fragmented UDP or ICMP packets ( for some games, s...  
 Enable Transparent mode

OK Cancel

**Filter Setup** | Set to Factory Default

Set	Comments	Set	Comments
1.	Default Call Filter	7.	
2.	Default Data Filter	8.	
3.		9.	
4.		10.	
5.		11.	
6.		12.	

**Filter Set 1**

Comments: Default Call Filter

Filter Rule	Active	Comments	Move Up
1	<input checked="" type="checkbox"/>	Block NetBios	UP
2	<input type="checkbox"/>		UP
3	<input type="checkbox"/>		UP
4	<input type="checkbox"/>		UP
5	<input type="checkbox"/>		UP
6	<input type="checkbox"/>		UP
7	<input type="checkbox"/>		UP

Next Filter

OK Clear Cancel

**Filter Set 1 Rule 1**

Check to enable the Filter Rule

Comments: Block NetBios

Index(1-15) in Schedule Setup: [ ] [ ] [ ] [ ]

Direction: LAN -> WAN

Source IP: Any [Edit]

Destination IP: Any [Edit]

Service Type: TCP/UDP, Port: from 137-139 to undefined [Edit]

Fragments: Don't Care

Application	Action/Profile	Syslog
Filter	Block Immediately	<input type="checkbox"/>
Branch to Other Filter Set:	None	<input type="checkbox"/>
IM/P2P Filter:	None	<input type="checkbox"/>
URL Content Filter	None	<input type="checkbox"/>
Web Content Filter	None	<input type="checkbox"/>
Anti-Virus:	None	<input type="checkbox"/>
Anti-Intrusion:	<input type="checkbox"/> Enable	<input type="checkbox"/>
Anti-Spam:	None	<input type="checkbox"/>

Advance Setting [Edit]

OK Clear Cancel

### 3.6.4 DoS Defense

As a sub-functionality of IP Filter/Firewall, there are 15 types of detect/defense function in the **DoS Defense** setup. The DoS Defense functionality is disabled for default.

Click **Firewall** and click **DoS Defense** to open the setup page.

#### Enable Dos Defense

Check the box to activate the DoS Defense Functionality.

#### Enable SYN flood defense

Check the box to activate the SYN flood defense function. Once detecting the Threshold of the TCP SYN packets from the Internet has exceeded the defined value, the Vigor router will start to randomly discard the subsequent TCP SYN packets for a period defined in Timeout. The goal for this is prevent the TCP SYN packets' attempt to exhaust the limited-resource of Vigor router. By default, the threshold and timeout values are set to 50 packets per second and 10 seconds, respectively.

#### Enable UDP flood defense

Check the box to activate the UDP flood defense function. Once detecting the Threshold of the UDP packets from the Internet has exceeded the defined value, the Vigor router will start to randomly discard the subsequent UDP packets for a period defined in Timeout. The default setting for threshold and timeout are 150 packets per second and 10 seconds, respectively.

#### Enable ICMP flood defense

Check the box to activate the ICMP flood defense function. Similar to the UDP flood defense function, once if the Threshold of ICMP packets from Internet has exceeded the defined value, the router will discard the ICMP echo requests coming from the Internet. The default setting for threshold and timeout are 50 packets per second and 10 seconds, respectively.

#### Enable PortScan detection

Port Scan attacks the Vigor router by sending lots of packets to many ports in an attempt to find ignorant services would respond. Check the box to activate the Port Scan detection. Whenever detecting this malicious exploration behavior by monitoring the port-scanning Threshold rate, the Vigor router will send out a warning. By default, the Vigor router sets the threshold as 150

packets per second.

- Block IP options** Check the box to activate the Block IP options function. The Vigor router will ignore any IP packets with IP option field in the datagram header. The reason for limitation is IP option appears to be a vulnerability of the security for the LAN because it will carry significant information, such as security, TCC (closed user group) parameters, a series of Internet addresses, routing messages...etc. An eavesdropper outside might learn the details of your private networks.
- Block Land** Check the box to enforce the Vigor router to defense the Land attacks. The Land attack combines the SYN attack technology with IP spoofing. A Land attack occurs when an attacker sends spoofed SYN packets with the identical source and destination addresses, as well as the port number to victims.
- Block Smurf** Check the box to activate the Block Smurf function. The Vigor router will ignore any broadcasting ICMP echo request.
- Block trace router** Check the box to enforce the Vigor router not to forward any trace route packets.
- Block SYN fragment** Check the box to activate the Block SYN fragment function. The Vigor router will drop any packets having SYN flag and more fragment bit set.
- Block Fraggle Attack** Check the box to activate the Block fraggle Attack function. Any broadcast UDP packets received from the Internet is blocked. Activating the DoS/DDoS defense functionality might block some legal packets. For example, when you activate the fraggle attack defense, all broadcast UDP packets coming from the Internet are blocked. Therefore, the RIP packets from the Internet might be dropped.
- Block TCP flag scan** Check the box to activate the Block TCP flag scan function. Any TCP packet with anomaly flag setting is dropped. Those scanning activities include *no flag scan*, *FIN without ACK scan*, *SYN FINscan*, *Xmas scan* and *full Xmas scan*.
- Block Tear Drop** Check the box to activate the Block Tear Drop function. Many machines may crash when receiving ICMP datagrams (packets) that exceed the maximum length. To avoid this type of attack, the Vigor router is designed to be capable of discarding any fragmented ICMP packets with a length greater than 1024 octets.
- Block Ping of Death** Check the box to activate the Block Ping of Death function. This attack involves the perpetrator sending overlapping packets to the target hosts so that those target hosts will hang once they re-construct the packets. The Vigor routers will block any packets realizing this attacking activity.
- Block ICMP Fragment** Check the box to activate the Block ICMP fragment function. Any ICMP packets with more fragment bit set are dropped.
- Block Unknown Protocol** Check the box to activate the Block Unknown Protocol function. Individual IP packet has a protocol field in the datagram header to indicate the protocol type running over the upper layer. However, the protocol types greater than 100 are reserved and undefined at this time. Therefore, the router should have ability to detect and

## Warning Messages

reject this kind of packets.

We provide Syslog function for user to retrieve message from Vigor router. The user, as a Syslog Server, shall receive the report sending from Vigor router which is a Syslog Client.

All the warning messages related to **DoS defense** will be sent to user and user can review it through Syslog daemon. Look for the keyword **DoS** in the message, followed by a name to indicate what kind of attacks is detected.

System Maintenance >> SysLog / Mail Alert Setup

### SysLog / Mail Alert Setup

SysLog Access Setup		Mail Alert Setup	
<input checked="" type="checkbox"/> Enable		<input type="checkbox"/> Enable	<input type="button" value="Send a test e-mail"/>
Router Name	<input type="text"/>	SMTP Server	<input type="text"/>
Server IP Address	<input type="text"/>	Mail To	<input type="text"/>
Destination Port	<input type="text" value="514"/>	Return-Path	<input type="text"/>
Enable syslog message:		<input type="checkbox"/> Authentication	
<input checked="" type="checkbox"/> Firewall Log		User Name	<input type="text"/>
<input checked="" type="checkbox"/> VPN Log		Password	<input type="text"/>
<input checked="" type="checkbox"/> User Access Log		Enable E-Mail Alert:	
<input checked="" type="checkbox"/> Call Log		<input checked="" type="checkbox"/> DoS Attack	
<input checked="" type="checkbox"/> WAN Log		<input checked="" type="checkbox"/> IM-P2P	
<input checked="" type="checkbox"/> Router/DSL information		<input checked="" type="checkbox"/> Anti-Intrusion	
		<input checked="" type="checkbox"/> Anti-Virus	

The screenshot shows the DrayTek Syslog application window. At the top, it displays the IP address 192.168.1.1 and the device model VigorPro5300 series. Below this, there are sections for LAN Status (TX Packets: 931, RX Packets: 1182) and WAN Status (Gateway IP, WAN IP, TX Packets, RX Rate, TX Rate). A central log window shows entries for DoS attacks, including 'DoS syn\_flood Block(10s)' and 'DoS icmp\_flood Block(10s)'. At the bottom, there is an ADSL Status section with fields for Mode (T1.413), State (HANDSHAKE), Up Speed (0), Down Speed (0), SNR Margin (0.0), and Loop Att (0.0).

## 3.7 Defense Configuration

This menu allows you to set profiles for, activate, and upgrade the service of Anti-Intrusion/Anti-Virus/Anti-Spam in your system.

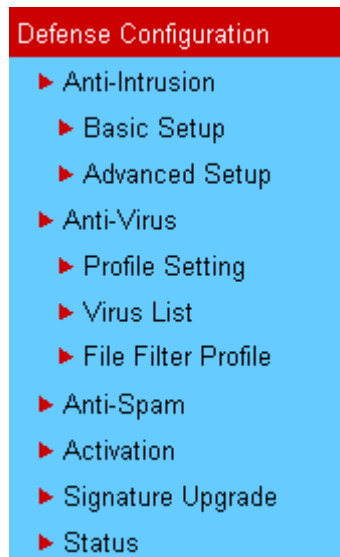

### 3.7.1 Anti-Intrusion

Anti-Intrusion allows you to prevent the intrusion from hackers while accessing into Internet. It can detect the intrusion and execute basic defense.

There are more than 200 basic rules for anti-intrusion and anti-virus for this router. To acquire more rules for anti-intrusion, it is suggested for you to register your router by entering [www.vigorpro.com](http://www.vigorpro.com). When you finished the registration, you can get and activate a wide range of anti-intrusion rules from the website. In addition, you will be allowed to download/update new rules (if they are released) from the websites lately (during the valid time of the license key you purchased) after completing the registration.

You are allowed to use trial version with anti-intrusion and anti-virus features for 30 days after you register for the router. And you will be noticed with an e-mail while it is going to expire.

#### 3.7.1.1 Basic Setup

**Basic Setup** page lets you to enable the anti-intrusion service and choose the suitable level for the detection.

**Anti-Intrusion Control Setup** [ Signature Version : **basic** ]

Enable Anti-Intrusion Service: Intrusion detection of the hacker is made effective

Sensitiveness of intrusion detection:

High Security: Matching all rules

Medium Security: Matching high and medium severity rules

Low Security: Matching high severity rules

Action's "default" processing at time of intrusion detection:

Enable Pass processing

Enable Disallow processing

Enable Reset processing

Note : If you want to email alert or syslog, please setup on the [SysLog/Mail Alert Setup](#) page. If you need more information, please enter [Advanced Setup](#)

**Anti-Intrusion Control Setup**

This field will display the signature version of this router. The default signature version is “**basic**”. In this version, you can modify the settings for Anti-Intrusion rules in **Defense Configuration>>Anti-Intrusion >>Advanced Setup** page. However, if you restart/reset the router, all the modified configurations for the rules will not be available and return to the default settings. Except “**basic**”, the modified configurations for other signature versions are available all the time after you saved them in **Defense Configuration>>Anti-Intrusion >>Advanced Setup** page.

**Enable Anti-Intrusion Service**

Check this box to enable the anti-intrusion function.

**High Security**

Click this radio button to activate the anti-intrusion service with overall detecting conditions. That is, the router will detect and block the incoming/outgoing packets which match all the severity rules, including high, medium and low. The degree of severity for each rule is defined in Advance Setup.

**Medium Security**

Click this radio button to activate the anti-intrusion service with medium detecting conditions. That is, the router will detect and block the incoming/outgoing packets which match the highest and medium severity rules. The degree of severity for each rule is defined in Advance Setup.

**Low Security**

Click this radio button to activate the anti-intrusion service with minimum detecting conditions. That is, the router will detect and block the incoming/outgoing packets which match the highest severity rules. The degree of severity for each rule is defined in **Advanced Setup**.

**Enable Pass processing**

Click this radio button to detect if there is any intrusion occurrence for your reference. The system will not do any advanced action for such condition.

**Enable Disallow processing**

Click this radio button to block the incoming/outgoing packets with possible intrusion actions transmitting through the router.

**Enable Reset procession** Click this radio button to break down the communication between your computer and specific link which might have intrusion actions.

### 3.7.1.2 Advanced Setup

This page lists all the available types and allows you to adjust the rule setting for each type. The rules will be applied by the options chosen in the page of **Defense Configuration>>Anti-Intrusion>>Basic Setup** for Anti-Intrusion.

Defense Configuration >> Anti-Intrusion >> Advanced Setup

Anti-Intrusion Type Setup		SID/NAME: <input type="text"/>	<input type="button" value="Search"/>
<a href="#">BO</a> (2)	<a href="#">Web-CGI</a> (3)		
<a href="#">DDoS/DoS</a> (4)	<a href="#">Web-Client</a> (1)		
<a href="#">Exploit</a> (47)	<a href="#">Web-IIS</a> (6)		
<a href="#">ICMP</a> (12)	<a href="#">Web-Misc</a> (5)		
<a href="#">I-Worm</a> (16)	<a href="#">Web-PHP</a> (0)		
<a href="#">IRC</a> (0)	<a href="#">Latest</a> (0)		
<a href="#">Malware</a> (41)			
<a href="#">Misc</a> (3)			
<a href="#">RPC</a> (5)			
<a href="#">Scan</a> (5)			
<a href="#">SQL-Inject</a> (0)			
<a href="#">Tunnel</a> (0)			

**SID/Name** To find the specific type of anti-intrusion, you can type its SID number or name in this field if you know, and then click **Search**. The system will locate that type for you.

**Search** It can help the user to find out specific anti-intrusion rule quickly.

**Type links** Click any anti-intrusion type link to access into next page for configuring the rules settings. Here we provide several rules for each type. The factory types and rules for anti-intrusion are shown in this page. If you want to acquire more types and rules, please go to [www.vigorpro.com](http://www.vigorpro.com) and finish the registration work. Later, the wide range of anti-intrusion types will be added into this page.

After you click any one of type links, you can access into the rules setup page for activating rules. We take the type of BO as an example. Below is the rules setup page for BO type.

For the detailed information about the full name, meaning of each rule and/or type, you can click the name link list on the Anti-Intrusion Rules Setup page to connect VigorPro webpage for viewing.



Anti-Intrusion Rules Setup Page: 1 / 1

Enable	Name	SID	Severity	Log	Action			
					Pass	Disallow	Reset	Default
<input checked="" type="checkbox"/>	<a href="#">Format String %n%n%n%n</a>	1336	M	<input checked="" type="checkbox"/>	<input type="radio"/>	<input type="radio"/>	<input type="radio"/>	<input checked="" type="radio"/>
<input checked="" type="checkbox"/>	<a href="#">SHELLCODE MIPS Ultrix NOOP</a>	1467	L	<input checked="" type="checkbox"/>	<input type="radio"/>	<input type="radio"/>	<input type="radio"/>	<input checked="" type="radio"/>
<input type="checkbox"/>		0		<input type="checkbox"/>	<input type="radio"/>	<input type="radio"/>	<input type="radio"/>	<input type="radio"/>
<input type="checkbox"/>		0		<input type="checkbox"/>	<input type="radio"/>	<input type="radio"/>	<input type="radio"/>	<input type="radio"/>
<input type="checkbox"/>		0		<input type="checkbox"/>	<input type="radio"/>	<input type="radio"/>	<input type="radio"/>	<input type="radio"/>
<input type="checkbox"/>		0		<input type="checkbox"/>	<input type="radio"/>	<input type="radio"/>	<input type="radio"/>	<input type="radio"/>
<input type="checkbox"/>		0		<input type="checkbox"/>	<input type="radio"/>	<input type="radio"/>	<input type="radio"/>	<input type="radio"/>
<input type="checkbox"/>		0		<input type="checkbox"/>	<input type="radio"/>	<input type="radio"/>	<input type="radio"/>	<input type="radio"/>
<input type="checkbox"/>		0		<input type="checkbox"/>	<input type="radio"/>	<input type="radio"/>	<input type="radio"/>	<input type="radio"/>
<input type="checkbox"/>		0		<input type="checkbox"/>	<input type="radio"/>	<input type="radio"/>	<input type="radio"/>	<input type="radio"/>

- Enable** Check to enable this rule. If you uncheck this box, the corresponding settings for the rule will not be executed.
- SID** The number for each anti-intrusion rule is displayed in this field.
- Name** A brief description name for the anti-intrusion rule is shown in this field. Click the name link to access into VigorPro website for checking the detailed information for the specified anti-intrusion.
- Severity** It means the degree of the influence for this type to the computer, machine, network and environment.  
 H: representing that this type will cause severest affection which must crash/destroy your computer.  
 M: representing that this type will cause severer affection which might crash your computer.  
 L: representing that this type will cause small affection which might not crash your computer.
- Log** In order to show the detection log with such rule on the window of Draytek Syslog, you have to check the log box here and enable the **SysLog Access Setup** from **System Maintenance >> Syslog/Mail Alert**.
- Action**
  - Pass** - Click this radio button to detect if there is any intrusion occurrence for your reference. The system will not do any advanced action for such condition.
  - Disallow** - Click this radio button to block the incoming/outgoing packets with possible intrusion actions transmitting through the router.
  - Reset** - Click this radio button to break down the communication between your computer and specific link which might have intrusion actions.
  - Default** - Click this radio button to execute the anti-intrusion detection according to the setting that you set in Basic Setup.
- Page** Type the page number in this field (if there is more than one page of anti-virus detail view displayed on this page). Then

click **Go** to the specified page. Or you can click **/>**, **>>**, **<<** or **>/** button on the right side of the **Go** button to access to the home/previous/next/end page.

## 3.7.2 Anti-Virus

Vigor router can offer basic virus scanning, destroying and cut off the connection between questionable link and your computer for the files transmitted through specified protocol. In addition, several types of compressed file formats such as .zip, .gzip, .bzip2 are supported and can be scanned with this router. There is no limitation in the file size for the transmitted (incoming or outgoing) file. With this feature, all the files processed with the protocol specified in Anti-Virus web page will be scanned for finding out virus while passing through the router.

**Note:** Files with three-layer compression (the files are compressed with six times) also can be scanned by this router.

### 3.7.2.1 Profile Setting

This page allows you to set eight profiles for anti-virus scanning. These profiles can be invoked through firewall configuration. It is recommended to build one profile at least. Thus you will have selectable anti-virus profile settings in **Firewall>>General Setup**.

Defense Configuration >> Anti-Virus >> Profile Setting

Anti-Virus Profile Table [Signature Version: **basic**] | **Set to Factory Default** |

Profile	Name	Profile	Name
<a href="#">1.</a>		<a href="#">5.</a>	
<a href="#">2.</a>		<a href="#">6.</a>	
<a href="#">3.</a>		<a href="#">7.</a>	
<a href="#">4.</a>		<a href="#">8.</a>	

Administration Message (Max 255 characters)

Email scanned by DrayTek VigorPro UTM.

**Note:** If you want to use email alert or syslog, please configure the **SysLog/Mail Alert Setup** page. For more information, please visit the **Virus List** page.

OK

The Administration Message box allows you to fill in important notification directly for SMTP and POP3 protocols. It will be saved as a file. While receiving an e-mail, the user will receive an attached file with the content listed in this box.

To edit a profile setting, please click the number link under Profile. You can see the following screen. You can check the boxes listed below for different operation respectively. If you uncheck this box, the corresponding settings for the protocol will not be performed.

Defense Configuration >> Anti-Virus >> Profile Setting

Profile Index : 1      Profile Name:

Operation/Protocol	SMTP	POP3	IMAP	HTTP	FTP
Action	Pass <input type="button" value="v"/>	Pass <input type="button" value="v"/>	Pass <input type="button" value="v"/>	Pass <input type="button" value="v"/>	Pass <input type="button" value="v"/>
Enable Virus Scan	<input checked="" type="checkbox"/>	<input type="checkbox"/>	<input type="checkbox"/>	<input type="checkbox"/>	<input type="checkbox"/>
Enable Log	<input checked="" type="checkbox"/>	<input checked="" type="checkbox"/>	<input checked="" type="checkbox"/>	<input checked="" type="checkbox"/>	<input checked="" type="checkbox"/>
Detect Macro Attachment	<input type="checkbox"/>	<input type="checkbox"/>	<input type="checkbox"/>	<input type="checkbox"/>	<input type="checkbox"/>
Detect Encrypted Zipped Files	<input type="checkbox"/>	<input type="checkbox"/>	<input type="checkbox"/>	<input type="checkbox"/>	<input type="checkbox"/>
Detect Suspicious Compression	<input type="checkbox"/>	<input type="checkbox"/>	<input type="checkbox"/>	<input type="checkbox"/>	<input type="checkbox"/>
Append Message	<input type="checkbox"/>	<input type="checkbox"/>			
<b>File Filter</b>	1-default <input type="button" value="v"/>	1-default <input type="button" value="v"/>	1-default <input type="button" value="v"/>	1-default <input type="button" value="v"/>	1-default <input type="button" value="v"/>
Block Fragmented Mail	<input type="checkbox"/>	<input type="checkbox"/>	<input type="checkbox"/>		
Block Multiple Sessions Download				<input type="checkbox"/>	

**Note:** If the document file is generated by Microsoft Office 2007 or earlier version, we advise you to enable **Detect Macro Attachment** function.

**Profile Name**

Type a name for the profile.

**Protocol**

Currently, only the files transmitted through the protocols listed in this page including **SMTP**, **POP3**, **IMAP**, **HTTP** and **FTP** will be scanned by this router.

**Action**

Choose the action that you want to apply to the protocols of each operation.

Action	Pass <input type="button" value="v"/>
	<div style="border: 1px solid black; padding: 2px;">             Pass              Destroy              Reset           </div>

**Pass** - Detect if there is any virus for your reference. The system will not do any advanced action for such condition.  
**Destroy**- Destroy the infected file found by the router system.  
**Reset** - Break down the communication between your computer and specific link which might have virus included.

**Enable Virus Scan**

Check this box to enable the general virus scan procedure for different protocols.

**Enable Log**

In order to show the virus detection log on the window of Draytek Syslog, you have to check the log box here and enable the **SysLog Access Setup** from **System Maintenance >> Syslog/Mail Alert**.

**SysLog / Mail Alert Setup**

**SysLog Access Setup**

Enable

Server IP Address

Destination Port

Enable syslog message:

- Firewall Log
- VPN Log
- User Access Log
- Call Log
- WAN Log
- Router/DSL information

**Detect Macro Attachment** The file with macro attachment will be passed/destroyed/reset under different protocols. The system will detect it automatically if you set corresponding configuration here.

**Detect Encrypted Zipped Files** The file zipped with encryption will be detected and then be passed/destroyed/reset according to the configuration set here.

**Detect Suspicious Compression** The file with suspicious or non-support compression format will be detected and then be passed/destroyed/reset according to the configuration set here.

**Append Message** This function is available for SMTP and POP3 protocols. If you check it, the message typed under the box of Administration Message will be sent out with e-mail.

**File Filter** Click this link to open **Defense Configuration>>Anti-Virus >>File Pattern List** for viewing current settings.

**Block Fragmented Mail** The file with fragmentations will be passed/destroyed/reset under different protocols. The router cannot execute the scanning job for some mail fragmentation if you check the boxes here.

**Block Multiple Sessions Download** The file with multiple sessions which are created by **HTTP** will be detected and then be passed/destroyed/reset according to the configuration set here.

### 3.7.2.2 Virus List

This page displays the virus list ordered by digits (0-9) and letters (A-Z). Each number after the letter link indicates the total types of the virus collected.

[Defense Configuration >> Anti-Virus >> Virus List](#)

Anti-Virus List Overview

SID/NAME:

<a href="#">0 - 9</a> (0)	<a href="#">M - N</a> (31)
<a href="#">A - B</a> (16)	<a href="#">O - P</a> (2)
<a href="#">C - D</a> (1)	<a href="#">Q - R</a> (2)
<a href="#">E - F</a> (2)	<a href="#">S - T</a> (21)
<a href="#">G - H</a> (0)	<a href="#">U - V</a> (0)
<a href="#">I - J</a> (2)	<a href="#">W - X</a> (0)
<a href="#">K - L</a> (4)	<a href="#">Y - Z</a> (1)

## SID/NAME

To find the specific type of anti-virus, you can type its SID number or name in this field if you know, and then click **Search**. The system will locate that rule for you.

## Search

Click this button to find out all the virus rules related to the SID/NAME that you entered. The page of the searching result will be shown as the following picture.

Defense Configuration >> Anti-Virus >> Virus List

Anti-Virus Search Result |< << >> >|

Name	SID
<a href="#">Baqla.AC</a>	21593
<a href="#">Baqla.AF</a>	22361
<a href="#">Baqla.AG</a>	22417
<a href="#">Baqla.BL</a>	34196
<a href="#">Baqla.BY-2</a>	35493
<a href="#">Baqla.BZ-1</a>	35496
<a href="#">Baqla.BZ-2</a>	35497
<a href="#">Baqla.CB</a>	35682
<a href="#">Baqla.CD-1</a>	35686
<a href="#">Baqla.CD-2</a>	35687

Click each name link to check the detailed information of the anti-virus rule.

## Detailed View for Anti-Virus

From the fourteen types of anti-virus list, click any one of them to access into next page. The detailed view list for anti-virus rule will be shown as below.

Defense Configuration >> Anti-Virus >> Virus List

Anti-Virus Detail View Page: 1 / 1  |< << >> >|

NAME	SID	NAME	SID
<a href="#">Baqla.AC</a>	21593	<a href="#">Baqla.Gen-9</a>	35683
<a href="#">Baqla.AF</a>	22361	<a href="#">Baqla.Z</a>	21339
<a href="#">Baqla.AG</a>	22417	<a href="#">Blaster.A</a>	18056
<a href="#">Baqla.BL</a>	34196	<a href="#">BugBear.B</a>	18078
<a href="#">Baqla.BY-2</a>	35493		0
<a href="#">Baqla.BZ-1</a>	35496		0
<a href="#">Baqla.BZ-2</a>	35497		0
<a href="#">Baqla.CB</a>	35682		0
<a href="#">Baqla.CD-1</a>	35686		0
<a href="#">Baqla.CD-2</a>	35687		0
<a href="#">Baqla.Gen-2</a>	22985		0
<a href="#">Baqla.Gen-7</a>	35505		0

## NAME

A brief description name for the anti-virus rule is shown in this field. Click the name link to access into VigorPro website for checking the detailed information for the specified anti-virus.

## SID

The number for each anti-virus rule is displayed in this field.

## Page

Type the page number in this field (if there is more than one page of anti-virus detail view displayed on this page). Then click **Go** to the specified page. Or you can click **/>**, **>>**, **<<** or **>/** button on the right side of the Go button to access to the home/previous/next/end page.

### 3.7.2.3 File Filter Profile

To avoid confidential file being leaked out by someone else through network and cause severe consequence, you can specify the file name in this page and determine to destroy or scan or pass it while the file passes through the router.

Before activating the File Filter Profile, you have to set one Anti-Virus profile on **Defense Configuration>>Anti-Virus>>Profile Setting**. Also you can specify file names without virus appended to be ignored by anti-virus server to improve the performance.

This page allows you to set 32 entries (rules) of file names to be filtered by the router. In such case, the file format is ignored. The router will destroy, scan or non-scan the specified filename according to the configuration that you set here.

**Defense Configuration >> Anti-Virus >> File Filter Profile**

File Filter Profile Table				<a href="#">Set to Factory Default</a>
Profile	Name	Profile	Name	
<a href="#">1.</a>	default	<a href="#">5.</a>		
<a href="#">2.</a>		<a href="#">6.</a>		
<a href="#">3.</a>		<a href="#">7.</a>		
<a href="#">4.</a>		<a href="#">8.</a>		

Click any number link to open the configuration page. Below is the page of **File Filter Profile**. The priority of each entry is determined by the index number. That is, the entry of Index 1 has the highest priority in file name filtering; the entry of Index 32 has the lowest priority in filtering.

**Defense Configuration >> Anti-Virus >> File Filter Profile >> Profile Setting**

**Profile Index: 1**      Profile Name:

Priority:       Default Action:

**Keyword**

Action	Group/Object Selections	
1. <input type="button" value="Scan"/>	<input type="text"/>	<input type="button" value="Edit"/>
2. <input type="button" value="Scan"/>	<input type="text"/>	<input type="button" value="Edit"/>
3. <input type="button" value="Scan"/>	<input type="text"/>	<input type="button" value="Edit"/>

**File Extension**

Action:       **Profile:**

Destroy the file if the file name is over length (Max 76 characters).

Syslog/Mail Alert:

#### Profile Name

Type a name for such profile.

#### Priority

Such item determines which profile will be executed first. If you choose File Extension First, Vigor router will filter the virus based on the file extension profile selected first, next filter the virus based on the keyword later; vice versa.

Priority:

File Extension First

Keyword First

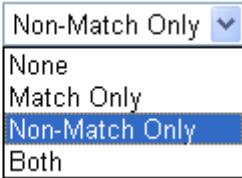
<b>Default Action</b>	Choose one of the actions (Scan, Non-Scan, Destroy) as the default action if the file does not meet the conditions configured below.
<b>Keyword</b>	<p>You can set three sets of keywords for this profile.</p> <p><b>Action -</b> Choose the action that you want to apply to the selected keyword.</p> <p><b>Destroy-</b> Destroy the file with name specified here which is found by the router system.</p> <p><b>Non-Scan</b> –The file will not be scanned and will not be processed by using general rules set in Anti-Virus profile.</p> <p><b>Scan</b> – Just scan the file with name specified here which is found by the router system, and be processed by using general rules set in Anti-Virus profile.</p> <p><b>Group/Object Selections -</b> Click <b>Edit</b> to choose the preset keyword groups and/or objects.</p>
<b>File Extension</b>	<p>Determine the filtering condition for downloading files.</p> <p><b>Action -</b> Choose the action that you want to apply to the selected file extension profile.</p> <p><b>Destroy-</b> Destroy the file with name specified here which is found by the router system.</p> <p><b>Non-Scan</b> –The file will not be scanned and will not be processed by using general rules set in Anti-Virus profile.</p> <p><b>Scan</b> – Just scan the file with name specified here which is found by the router system, and be processed by using general rules set in Anti-Virus profile.</p> <p><b>Profile</b> – Use the drop down list to specify one profile to be executed as filtering condition.</p>
<b>Destroy the file if the file name is over length</b>	Check this box to destroy the file with filename over 76 characters.
<b>Syslog/Mail Alert</b>	<p>Specify the condition for the system to send Syslog/Mail Alert for the default action.</p> <p>Syslog/Mail Alert: </p> <p><b>None</b> – No action will be recorded in Syslog.</p> <p><b>Match Only-</b> Only the log that matching with the above condition will be recorded in Syslog.</p> <p><b>No-Match Only</b> – Only the log that not matching with the above condition will be recorded in Syslog.</p> <p><b>Both</b> – All the actions will be recorded in Syslog.</p>

Click **OK** to finish the page configuration.

### 3.7.3 Anti-Spam

Many people suffer with unwanted mails coming from everywhere. Such device offers a mechanism, named Anti-Spam, to do basic scanning for filtering unnecessary mails and sorting the mails.

To activate function of Anti-Spam, you **have to configure profile(s) for your computer first**. Please open **Defense Configuration>>Anti- Spam** menu to access into the following page. There are sixteen profiles provided by this system for you to define.

Defense Configuration >> Anti-Spam >> Profile Setting

Anti-Spam Profile Table				<a href="#">Set to Factory Default</a>
Profile	Name	Profile	Name	
<a href="#">1.</a>		<a href="#">9.</a>		
<a href="#">2.</a>		<a href="#">10.</a>		
<a href="#">3.</a>		<a href="#">11.</a>		
<a href="#">4.</a>		<a href="#">12.</a>		
<a href="#">5.</a>		<a href="#">13.</a>		
<a href="#">6.</a>		<a href="#">14.</a>		
<a href="#">7.</a>		<a href="#">15.</a>		
<a href="#">8.</a>		<a href="#">16.</a>		

### Profile (1 ~16)

There are sixteen profiles provided for you to define. Simply click the number link under Profile, the setting page for that number will be open for you to configure.

### Name

List the name for the profile setting.

### 3.7.3.1 Profile Setting

Simply click number under Profile item. The detailed page will be shown right away. The following graphic is the web page for the profile marked with number 1.

Defense Configuration >> Anti-Spam >> Profile Setting

Profile Index : 1      Profile Name:

**Choose Protocol to Scan Spam**       Log All Mail Events

SMTP     POP3

**Select an Action for Each Category**

Category	Action	Log	Message(Max 30 characters)
Spam	Tag <input type="button" value="v"/>	<input checked="" type="checkbox"/>	***VigorPro SPAM*** <input type="text"/>
Bulk	Tag <input type="button" value="v"/>	<input checked="" type="checkbox"/>	***VigorPro BULK*** <input type="text"/>

**Enable Black/White List**       Log Matched Events

Priority Selection

Destroy Tag Message(Max 30 characters)

Action	Group/Object Selections	
Sender	Pass <input type="button" value="v"/>	<input type="text"/> <input type="button" value="Edit"/>
Receiver	Pass <input type="button" value="v"/>	<input type="text"/> <input type="button" value="Edit"/>
Subject	Pass <input type="button" value="v"/>	<input type="text"/> <input type="button" value="Edit"/>

**Choose Action for System Timeout or Network Problem**

Action	Log	Message(Max 30 characters)
System Fail	Pass <input type="button" value="v"/>	<input type="checkbox"/> <input type="text"/>



**Profile Name**

Type a name for such profile setting.

**Choose Protocol to Scan Spam**

Spam files usually come with protocol of SMTP or POP3. Please check the box that you want to avoid. It would be better to check both protocols. In addition, you can check **Log All Mail Events** to send record of all mail events to syslog.

**Select an Action for Each Category**

Mails would be judged and categorized into Spam, Bulk or normal mails. For the one that is confirmed as spam will be processed with the rule of **Spam**; and the one that is probably spam will be processed with the rule of **Bulk**. Please set different process action for Spam and Bulk respectively.

**Pass** - Choose this action to make all mails passing through.

**Tag** - Choose this action to make all mails be tagged with certain words for you to identify easily. For example, type "SPAM" on the box of **Message**. If the subject of some mail is "license page" and it is judged as spam, then it will be shown as "\*\*\*SPAM\*\*\* license page" in your mail box. Such tag can help users to identify which mail is useful or useless quickly.

**Reset** - Choose this action to disconnect the network. It is mainly applied on SMTP server.

Tag	▼
Pass	
Tag	
Reset	

**Enable Black and White List**

Check this box to enable black and white list settings.

**Priority Selection** - Choose **Pass First** for passing the mails matching with **Black and White List** first, or choose **Destroy First** for destroying the content of mail matching with **Black and White List** first.

Priority Selection	Destroy First ▼
	Pass First
	Destroy First

**Log Matched Events** - Check this box to record all the matched events of mails on Syslog.

**Destroy Tag Message (Max 30 characters)** - Type the character(s) as a tag for destroying.

**Action** - Determines the action (**Pass** or **Destroy**) for the emails coming from the sender, or for the emails sending out from the receiver, or for the subject with the keyword selected here.

Action	
Sender	Destroy ▼
Receiver	Pass Destroy
Subject	Pass ▼

**Group/Object Selections** - Choose a suitable group or object for passing or blocking. Click **Edit** to open the

following dialog. The keyword/group that you have set on **Object Settings>>Keyword Object/ Object Settings>>Keyword Group** will be displayed here for you to choose.



### Choose Action for System Timeout or Network Problem

When the system fails due to system timeout or network problem, you can specify specific action (Pass or Tag) for the system to execute immediately.

**Pass** - Choose this action to make all mails passing through.

**Tag** - Choose this action to make all mails be tagged with certain words for you to identify easily. For example, type “timeout” on the box of **Message**. Then all the mails sending to your e-mail box at system timeout will be marked with “\*\*\*timeout\*\*\*” before the subjects of the mails. Later, these mails can be identified easily and categorized manually.

#### Action

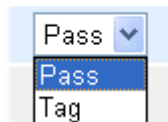

**Log** - Check the box to have the process record stated on Syslog.

**Message** - Type words which will be placed before the subject of mail and help you to identify.

### Clear

Delete the settings configured above and reset to default settings.

### Cancel

Delete the settings configured above and return to previous page.

Click **OK** to finish the page configuration.

## 3.7.4 Activation Anti-Intrusion/Anti-Virus/Anti-Spam Service

After you have finished the profile settings, it is the time to activate the mechanism for your computer. Click **Defense Configuration>>Activation** to open the following page for accessing [www.vigorpro.com](http://www.vigorpro.com).

Defense Configuration >> Activation

**Anti-Intrusion/Anti-Virus License**

[Activate](#)

[Status:DT-DT] [Start Date:2006-07-27 Expire Date:2009-07-27]

**Anti-Spam License**

[Activate](#)

[Status:Not Activated]

Authentication Message

```
Anti-Spam, service not activate 2000-01-01 00:15:14
AV/AI, Activation authenticate fail, contact with support@draytek.com, 2000-01-01
00:15:14
```

**Note:** If you want to use email alert or syslog, please configure the [SysLog/Mail Alert Setup](#) page.

**Activate**

The **Activate** link brings you accessing into [www.vigorpro.com](http://www.vigorpro.com) to finish the activation of the account and the router.

**Authentication Message**

As for authentication information of **Anti-Intrusion/Anti-Virus/Anti-Spam**, the process of authenticating will be displayed on this field for your reference.

### 3.7.5 Signature Upgrade

You can get the most updated signature from DrayTek's server if the license key of anti-virus/anti-intrusion for the VigorPro5300 is not expired. Before you upgrade the signature, please check the validation information either from WEB user interface of VigorPro5300 or account information from [www.vigorpro.com](http://www.vigorpro.com).

Defense Configuration >> Signature Upgrade

**Signature Upgrade Setting**

Signature Version : **basic**

Signature Build Date : **Tue Aug 29 09:16:25.00 2006**

<b>Setup download server</b>	<input type="text" value="auto-selected"/>	<a href="#">find more</a>
<b>Setup query server</b>	<input type="text" value="auto-selected"/>	<a href="#">find more</a>
Signature authentication/download message:		
<input type="text"/>		

**Upgrade Manually**

**Upgrade Automatically**

Scheduled Update

<input checked="" type="radio"/> Every:	<input type="text" value="1"/> (hour)	<input type="text" value="00"/> (minutes after the hour)
<input type="radio"/> Daily:	<input type="text" value="0"/> (hour)	<input type="text" value="00"/> (minute)
<input type="radio"/> Weekly:	<input type="text" value="Sunday"/> (day)	<input type="text" value="0"/> (hour) <input type="text" value="00"/> (minute)

### Signature Upgrade Setting

It displays the signature version for your reference. There are three levels for the signature:

**basic** – If you did not register and activate your account, you can just own the default 200 (or more) anti-intrusion and anti-virus rules for your router.

**DT-DT/DT-KL\_XXXXXX** – If you have registered and activated your AI/AV account, and downloaded the newest rules from [www.vigorpro.com](http://www.vigorpro.com), you can see DT-DT/DT-KL in this field that means you have obtained the latest signature information.

### Setup download server/Setup query server

The default setting is auto-selected. You can change the setting if it is required to be. Click the **find more** link to get more information.

Please choose a download server / query server of the continent that your router is located.

Zone Name	Download Server	Query Server
Africa	<a href="http://www.vigorpro.com">www.vigorpro.com</a>	<a href="http://www.vigorpro.com">www.vigorpro.com</a>
America	<a href="http://www.vigorpro.com">www.vigorpro.com</a>	<a href="http://www.vigorpro.com">www.vigorpro.com</a>
Asia	<a href="http://www.vigorpro.com">www.vigorpro.com</a>	<a href="http://www.vigorpro.com">www.vigorpro.com</a>
Europe	<a href="http://www.vigorpro.com">www.vigorpro.com</a>	<a href="http://www.vigorpro.com">www.vigorpro.com</a>
Oceania	<a href="http://www.vigorpro.com">www.vigorpro.com</a>	<a href="http://www.vigorpro.com">www.vigorpro.com</a>
The Antarctic	<a href="http://www.vigorpro.com">www.vigorpro.com</a>	<a href="http://www.vigorpro.com">www.vigorpro.com</a>

### Signature authentication/download message

It displays the message of signature authentication or download procedure.

### Upgrade Manually

The buttons in this field are only available when you finished the registration and activation for new account and your router. If not, these buttons do not have any effect even if you click them.

**Import** – You can import a saved file to manually upgrade the signature. Click **Browse** to choose the right file with **.sig** file format. Next, click **Upgrade**.

System Maintenance >> Signature Upgrade

Signature Upgrade Manually [ Signature Version : basic ]

**Upgrade Signature**

Select a signature file.

Click Upgrade to upload the file.

**Backup** - You can backup current signature information with the filename vigorpro.sig.

**Download Now!!!** – This button will download newly update anti-intrusion and anti-virus from VigorPro website. While downloading the file, a progress bar will be shown as follows.

### Signature Upgrade Setting

Signature Version : **basic**  
Signature Build Date : **Tue Aug 29 09:16:25.00 2006**

<b>Setup download server</b>	auto-selected	<a href="#">find more</a>
<b>Setup query server</b>	auto-selected	<a href="#">find more</a>
Signature download progress: <b>24%</b> 		
Signature authentication/download message: <div style="border: 1px solid gray; height: 40px;"></div>		
<b>Upgrade Manually</b> <input type="button" value="Import"/> <input type="button" value="Backup"/> <input type="button" value="Download Now !!!"/>		

After downloading is finished, the signature version will be upgraded and displayed on the web page.

### Signature Upgrade Setting

Signature Version : **DT-DT\_1\_61\_5\_4**  
Signature Build Date : **Tue Aug 29 09:16:25.00 2006**

<b>Setup download server</b>	auto-selected	<a href="#">find more</a>
<b>Setup query server</b>	auto-selected	<a href="#">find more</a>
Signature authentication/download message: <div style="border: 1px solid gray; padding: 2px;">Load signature successful, 2007-06-06 07:13:43</div>		
<b>Upgrade Manually</b> <input type="button" value="Import"/> <input type="button" value="Backup"/> <input type="button" value="Download Now !!!"/>		

### Upgrade Automatically

Specify certain time for executing the upgrade automatically. Remember to check the **Schedule Update** box to activate the time settings.

**Every** – It means the downloading procedure will be executed automatically whenever passing through the time (hours and minutes) that you set here.

**Daily** - It means the downloading procedure will be automatically executed every day at the time (hours and minutes) that you set here.

**Weekly** - It means the downloading procedure will be automatically executed at the time (hours and minutes) that you set here every week.

<b>Upgrade Automatically</b>			
<input checked="" type="checkbox"/> Scheduled Update			
<input checked="" type="radio"/> Every:	1	(hour)	00 (minutes after the hour)
<input type="radio"/> Daily:	0	(hour)	00 (minute)
<input type="radio"/> Weekly:	Sunday	(day)	0 (hour) 00 (minute)
<input type="button" value="OK"/> <input type="button" value="Cancel"/>			

### 3.7.6 Status

This field will show the status for the license, start date and expire date for Anti-Intrusion/Anti-Virus and Anti-Spam services. If your account or router is still not activated, the word **Not Activated** will be displayed here to inform you. Below is a sample page with valid license.

#### Anti-Intrusion/Anti-Virus License

[Status: **Not Activated**]

Signature Version	: basic	Signature Build Date	: Tue Aug 29 09:16:25.00 2006
Current Download Server	: auto-selected	Current Query Server	: auto-selected
Signature Authentication/Download Message for Anti-Intrusion/Anti-Virus:			
<input type="text"/>			

#### Anti-Spam License

[Status: **Not Activated**]

Authentication Message for Anti-Spam	
<input type="text" value="AntiSpam service not activate 2000-01-01 00:00:23"/>	

## 3.8 Bandwidth Management

Below shows the menu items for Bandwidth Management.

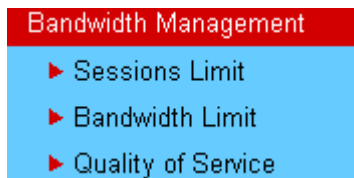

### 3.8.1 Sessions Limit

A PC with private IP address can access to the Internet via NAT router. The router will generate the records of NAT sessions for such connection. The P2P (Peer to Peer) applications (e.g., BitTorrent) always need many sessions for procession and also they will occupy over resources which might result in important accesses impacted. To solve the problem, you can use limit session to limit the session procession for specified Hosts.

In the **Bandwidth Management** menu, click **Sessions Limit** to open the web page.

**Sessions Limit**

Enable
  Disable

Default Max Sessions:

**Limitation List**

Index	Start IP	End IP	Max Sessions

**Specific Limitation**

Start IP:  End IP:

Maximum Sessions:

---

**Time Schedule**

Index(1-15) in **Schedule** Setup: , , ,

**Note:** Action and Idle Timeout settings will be ignored.

To activate the function of limit session, simply click **Enable** and set the default session limit.

- Enable** Click this button to activate the function of limit session.
- Disable** Click this button to close the function of limit session.
- Default session limit** Defines the default session number used for each computer in LAN.
- Limitation List** Displays a list of specific limitations that you set on this web page.
- Start IP** Defines the start IP address for limit session.
- End IP** Defines the end IP address for limit session.
- Maximum Number** Defines the available session number for each host in the specific range of IP addresses. If you do not set the session number in this field, the system will use the default session limit for the specific limitation you set for each index.
- Add** Adds the specific session limitation onto the list above.
- Edit** Allows you to edit the settings for the selected limitation.
- Delete** Delete the selected settings existing on the limitation list.
- Index (1-15) in Schedule Setup** You can type in four sets of time schedule for your request. All the schedules can be set previously in **Application – Schedule** web page and you can use the number that you have set in that web page.

### 3.8.2 Bandwidth Limit

The downstream or upstream from FTP, HTTP or some P2P applications will occupy large of bandwidth and affect the applications for other programs. Please use Limit Bandwidth to make the bandwidth usage more efficient.

In the **Bandwidth Management** menu, click **Bandwidth Limit** to open the web page.

Bandwidth Management >> Bandwidth Limit

**Bandwidth Limit**

Enable    Disable

Default TX Limit:  Kbps    Default RX Limit:  Kbps

**Limitation List**

Index	Start IP	End IP	TX limit	RX limit

**Specific Limitation**

Start IP:     End IP:   
 TX Limit:  Kbps    RX Limit:  Kbps

---

**Time Schedule**

Index(1-15) in **Schedule** Setup: , , ,

**Note:** Action and Idle Timeout settings will be ignored.

To activate the function of limit bandwidth, simply click **Enable** and set the default upstream and downstream limit.

- Enable**                                      Click this button to activate the function of limit bandwidth.
- Disable**                                    Click this button to close the function of limit bandwidth.
- Default TX limit**                        Define the default speed of the upstream for each computer in LAN.
- Default RX limit**                        Define the default speed of the downstream for each computer in LAN.
- Limitation List**                         Display a list of specific limitations that you set on this web page.
- Start IP**                                    Define the start IP address for limit bandwidth.
- End IP**                                      Define the end IP address for limit bandwidth.
- TX limit**                                    Define the limitation for the speed of the upstream. If you do not set the limit in this field, the system will use the default speed for the specific limitation you set for each index.
- RX limit**                                    Define the limitation for the speed of the downstream. If you do not set the limit in this field, the system will use the default speed for the specific limitation you set for each index.
- Add**                                        Add the specific speed limitation onto the list above.
- Edit**                                         Allows you to edit the settings for the selected limitation.
- Delete**                                      Delete the selected settings existing on the limitation list.
- Index (1-15) in Schedule Setup**      You can type in four sets of time schedule for your request. All the schedules can be set previously in **Application – Schedule** web page and you can use the number that you



have set in that web page.

### 3.8.3 Quality of Service

Deploying QoS (Quality of Service) management to guarantee that all applications receive the service levels required and sufficient bandwidth to meet performance expectations is indeed one important aspect of modern enterprise network.

One reason for QoS is that numerous TCP-based applications tend to continually increase their transmission rate and consume all available bandwidth, which is called TCP slow start. If other applications are not protected by QoS, it will detract much from their performance in the overcrowded network. This is especially essential to those are low tolerant of loss, delay or jitter (delay variation).

Another reason is due to congestions at network intersections where speeds of interconnected circuits mismatch or traffic aggregates, packets will queue up and traffic can be throttled back to a lower speed. If there's no defined priority to specify which packets should be discarded (or in another term "dropped") from an overflowing queue, packets of sensitive applications mentioned above might be the ones to drop off. How this will affect application performance?

There are two components within Primary configuration of QoS deployment:

- **Classification:** Identifying low-latency or crucial applications and marking them for high-priority service level enforcement throughout the network.
- **Scheduling:** Based on classification of service level to assign packets to queues and associated service types

The basic QoS implementation in Vigor routers is to classify and schedule packets based on the service type information in the IP header. For instance, to ensure the connection with the headquarter, a teleworker may enforce an index of QoS Control to reserve bandwidth for HTTPS connection while using lots of application at the same time.

One more larger-scale implementation of QoS network is to apply DSCP (Differentiated Service Code Point) and IP Precedence disciplines at Layer 3. Compared with legacy IP Precedence that uses Type of Service (ToS) field in the IP header to define 8 service classes, DSCP is a successor creating 64 classes possible with backward IP Precedence compatibility. In a QoS-enabled network, or Differentiated Service (DiffServ or DS) framework, a DS domain owner should sign a Service License Agreement (SLA) with other DS domain owners to define the service level provided toward traffic from different domains. Then each DS node in these domains will perform the priority treatment. This is called per-hop-behavior (PHB). The definition of PHB includes Expedited Forwarding (EF), Assured Forwarding (AF), and Best Effort (BE). AF defines the four classes of delivery (or forwarding) classes and three levels of drop precedence in each class.

Vigor routers as edge routers of DS domain shall check the marked DSCP value in the IP header of bypassing traffic, thus to allocate certain amount of resource execute appropriate policing, classification or scheduling. The core routers in the backbone will do the same checking before executing treatments in order to ensure service-level consistency throughout the whole QoS-enabled network.

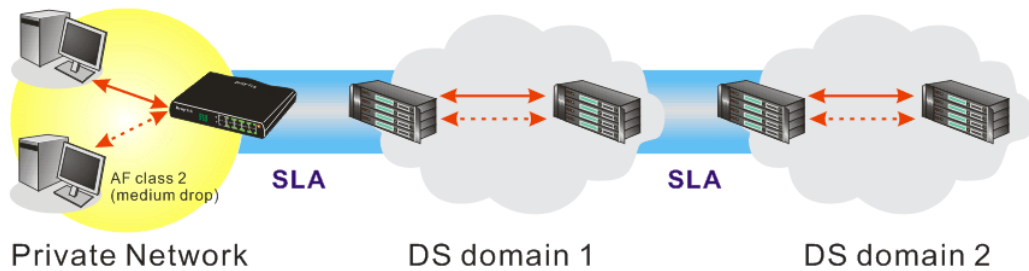

However, each node may take different attitude toward packets with high priority marking since it may bind with the business deal of SLA among different DS domain owners. It's not easy to achieve deterministic and consistent high-priority QoS traffic throughout the whole network with merely Vigor router's effort.

In the **Bandwidth Management** menu, click **Quality of Service** to open the web page.

**Bandwidth Management >> Quality of Service**

#### General Setup

Index	Status	Bandwidth	Directon	Class 1	Class 2	Class 3	Others	UDP Bandwidth Control	
WAN1	Disable	10000Kbps/10000Kbps		25%	25%	25%	25%	Inactive	<a href="#">Setup</a>
WAN2	Disable	10000Kbps/10000Kbps		25%	25%	25%	25%	Inactive	<a href="#">Setup</a>

#### Class Rule

Index	Name	Rule	Service Type
Class 1		<a href="#">Edit</a>	<a href="#">Edit</a>
Class 2		<a href="#">Edit</a>	
Class 3		<a href="#">Edit</a>	

This page displays the QoS settings result of the WAN interface. Click the **Setup** link to access into next page for the general setup of WAN (1/2) interface. As to class rule, simply click the **Edit** link to access into next for configuration.

You can configure general setup for the WAN interface, edit the Class Rule, and edit the Service Type for the Class Rule for your request.

### General Setup for WAN Interface

When you click **Setup**, you can configure the bandwidth ratio for QoS of the WAN interface. There are four queues allowed for QoS control. The first three (Class 1 to Class 3) class rules can be adjusted for your necessity. Yet, the last one is reserved for the packets which are not suitable for the user-defined class rules.

WAN1 General Setup

Enable the QoS Control OUT

WAN Inbound Bandwidth  Kbps

WAN Outbound Bandwidth  Kbps

Index	Class Name	Reserved_bandwidth Ratio
Class 1		<input type="text" value="25"/> %
Class 2		<input type="text" value="25"/> %
Class 3		<input type="text" value="25"/> %
	Others	<input type="text" value="25"/> %

Enable UDP Bandwidth Control Limited\_bandwidth Ratio  %

Outbound TCP ACK Prioritize

**Enable the QoS Control** The factory default for this setting is checked. Please also define which traffic the QoS Control settings will apply to.  
**IN-** apply to incoming traffic only.  
**OUT-** apply to outgoing traffic only.  
**BOTH-** apply to both incoming and outgoing traffic.  
 Check this box and click **OK**, then click **Setup** link again. You will see the **Online Statistics** link appearing on this page.

**WAN Inbound Bandwidth** It allows you to set the connecting rate of data input for WAN. For example, if your ADSL supports 1M of downstream and 256K upstream, please set 10000kbps for this box. The default value is 10000kbps.

**WAN Outbound Bandwidth** It allows you to set the connecting rate of data output for WAN. For example, if your ADSL supports 1M of downstream and 256K upstream, please set 256kbps for this box. The default value is 10000kbps.

**Reserved Bandwidth Ratio** It is reserved for the group index in the form of ratio of **reserved bandwidth to upstream speed** and **reserved bandwidth to downstream speed**.

**Enable UDP Bandwidth Control** Check this and set the limited bandwidth ratio on the right field. This is a protection of TCP application traffic since UDP application traffic such as streaming video will exhaust lots of bandwidth.

**Outbound TCP ACK Prioritize** The difference in bandwidth between download and upload are great in ADSL2+ environment. For the download speed might be impacted by the uploading TCP ACK, you can check this box to push ACK of upload more faster to speed the network traffic.

**Limited\_bandwidth Ratio** The ratio typed here is reserved for limited bandwidth of UDP application.

**Online Statistics** Display an online statistics for quality of service for your reference. This link will be seen only if you click **OK** in WAN1/WAN2 General Setup web page and click Setup again

(for WAN1/WAN2) on the **Bandwidth Management >> Quality of Service**.

Bandwidth Management >> Quality of Service

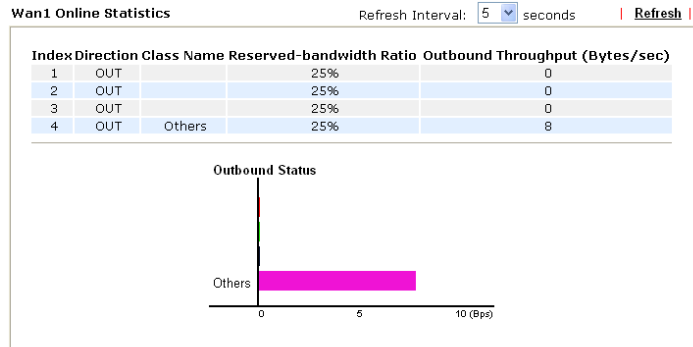

### Edit the Class Rule for QoS

The first three (Class 1 to Class 3) class rules can be adjusted for your necessity. To add, edit or delete the class rule, please click the **Edit** link of that one.

Bandwidth Management >> Quality of Service

#### General Setup

Index	Status	Bandwidth	Directon	Class 1	Class 2	Class 3	Others	UDP Bandwidth Control	
WAN1	Disable	10000Kbps/10000Kbps		25%	25%	25%	25%	Inactive	<a href="#">Setup</a>
WAN2	Disable	10000Kbps/10000Kbps		25%	25%	25%	25%	Inactive	<a href="#">Setup</a>

#### Class Rule

Index	Name	Rule	Service Type
Class 1		<a href="#">Edit</a>	<a href="#">Edit</a>
Class 2		<a href="#">Edit</a>	
Class 3		<a href="#">Edit</a>	

After you click the **Edit** link, you will see the following page. Now you can define the name for that Class. In this case, "Test" is used as the name of Class Index #1.

Bandwidth Management >> Quality of Service

#### Class Index #1

Name

NO	Status	Local Address	Remote Address	DiffServ CodePoint	Service Type
1	Empty	-	-	-	-

For adding a new rule, click **Add** to open the following page.

**Bandwidth Management >> Quality of Service**

**Rule Edit**

ACT

Local Address

Remote Address

DiffServ CodePoint

Service Type

**Note:** Please choose/setup the **Service Type** first.

**ACT**

Check this box to invoke these settings.

**Local Address**

Click the **Edit** button to set the local IP address (on LAN) for the rule.

**Remote Address**

Click the **Edit** button to set the remote IP address (on Lan/WAN) for the rule.

**Edit**

It allows you to edit source address information.

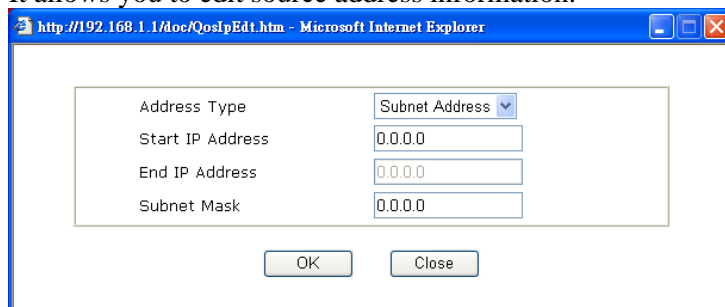

**Address Type** – Determine the address type for the source address.

For **Single Address**, you have to fill in Start IP address.

For **Range Address**, you have to fill in Start IP address and End IP address.

For **Subnet Address**, you have to fill in Start IP address and Subnet Mask.

**DiffServ CodePoint**

All the packets of data will be divided with different levels and will be processed according to the level type by the system. Please assign one of the level of the data for processing with QoS control.

**Service Type**

It determines the service type of the data for processing with QoS control. It can also be edited. You can choose the predefined service type from the Service Type drop down list. Those types are predefined in factory. Simply choose the one that you want for using by current QoS.

By the way, you can set up to 20 rules for one Class. If you want to edit an existed rule, please select the radio button of that one and click **Edit** to open the rule edit page for modification.

**Class Index # 1**

Name

NO	Status	Local Address	Remote Address	DiffServ CodePoint	Service Type
1 <input type="radio"/>	Active	Any	Any	IP precedence 2	ANY
2 <input type="radio"/>	Active	192.168.1.66	Any	ANY	TFTP(UDP:69)

### Edit the Service Type for Class Rule

To add a new service type, edit or delete an existed service type, please click the Edit link under Service Type field.

**General Setup**

Index	Status	Bandwidth	Directon	Class 1	Class 2	Class 3	Others	UDP Bandwidth Control	
WAN1	Disable	10000Kbps/10000Kbps		25%	25%	25%	25%	Inactive	<a href="#">Setup</a>
WAN2	Disable	10000Kbps/10000Kbps		25%	25%	25%	25%	Inactive	<a href="#">Setup</a>

**Class Rule**

Index	Name	Rule	Service Type
Class 1		<a href="#">Edit</a>	<a href="#">Edit</a>
Class 2		<a href="#">Edit</a>	
Class 3		<a href="#">Edit</a>	

After you click the **Edit** link, you will see the following page.

**User Defined Service Type**

NO	Name	Protocol	Port
1	Empty	-	-

For adding a new service type, click **Add** to open the following page.

**Service Type Edit**

Service Name	<input type="text" value="Game"/>
Service Type	<input type="text" value="TCP"/> <input type="text" value="6"/>
Port Configuration	
Type	<input checked="" type="radio"/> Single <input type="radio"/> Range
Port Number	<input type="text" value="88"/> - <input type="text" value="0"/>

**Service Name**

Type in a new service for your request.

**Service Type**

Choose the type (TCP, UDP or TCP/UDP) for the new service.

**Port Configuration**

Click **Single** or **Range**. If you select Range, you have to type in the starting port number and the end porting number on the boxes below.

**Port Number** – Type in the starting port number and the end porting number here if you choose Range as the type.

By the way, you can set up to 40 service types. If you want to edit/delete an existed service type, please select the radio button of that one and click **Edit/Edit** for modification.

## 3.9 Applications

Below shows the menu items for Applications.

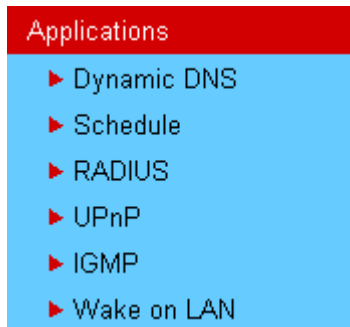

### 3.9.1 Dynamic DNS

The ISP often provides you with a dynamic IP address when you connect to the Internet via your ISP. It means that the public IP address assigned to your router changes each time you access the Internet. The Dynamic DNS feature lets you assign a domain name to a dynamic WAN IP address. It allows the router to update its online WAN IP address mappings on the specified Dynamic DNS server. Once the router is online, you will be able to use the registered domain name to access the router or internal virtual servers from the Internet. It is particularly helpful if you host a web server, FTP server, or other server behind the router.

Before you use the Dynamic DNS feature, you have to apply for free DDNS service to the DDNS service providers. The router provides up to three accounts from three different DDNS service providers. Basically, Vigor routers are compatible with the DDNS services supplied by most popular DDNS service providers such as [www.dyndns.org](http://www.dyndns.org), [www.no-ip.com](http://www.no-ip.com), [www.dtdns.com](http://www.dtdns.com), [www.changeip.com](http://www.changeip.com), [www.dynamic-nameserver.com](http://www.dynamic-nameserver.com). You should visit their websites to register your own domain name for the router.

#### Enable the Function and Add a Dynamic DNS Account

1. Assume you have a registered domain name from the DDNS provider, say *hostname.dyndns.org*, and an account with username: *test* and password: *test*.
2. In the DDNS setup menu, check **Enable Dynamic DNS Setup**.

Applications >> Dynamic DNS Setup

The screenshot shows the 'Dynamic DNS Setup' configuration page. At the top right, there is a link 'Set to Factory Default'. Below this, there is a checkbox labeled 'Enable Dynamic DNS Setup' which is checked. To the right of the checkbox are two buttons: 'View Log' and 'Force Update'. Below the checkbox is a section titled 'Accounts :'. This section contains a table with four columns: 'Index', 'WAN Interface', 'Domain Name', and 'Active'. There are three rows in the table, each with an underlined index (1, 2, 3), 'WAN1 First' in the WAN Interface column, a period '.' in the Domain Name column, and an 'x' in the Active column.

Index	WAN Interface	Domain Name	Active
<u>1.</u>	WAN1 First	.	x
<u>2.</u>	WAN1 First	.	x
<u>3.</u>	WAN1 First	.	x

OK Clear All

**Set to Factory Default** Clear all profiles and recover to factory settings.

**Enable Dynamic DNS Setup** Check this box to enable DDNS function.

**Index** Click the number below Index to access into the setting page of DDNS setup to set account(s).



<b>WAN Interface</b>	Display current WAN interface used for accessing Internet.
<b>Domain Name</b>	Display the domain name that you set on the setting page of DDNS setup.
<b>Active</b>	Display if this account is active or inactive.
<b>View Log</b>	Display DDNS log status.
<b>Force Update</b>	Force the router updates its information to DDNS server.

3. Select Index number 1 to add an account for the router. Check **Enable Dynamic DNS Account**, and choose correct Service Provider: dyndns.org, type the registered hostname: *hostname* and domain name suffix: dyndns.org in the **Domain Name** block. The following two blocks should be typed your account Login Name: *test* and Password: *test*.

Applications >> Dynamic DNS Setup >> Dynamic DNS Account Setup

**Index : 1**

Enable Dynamic DNS Account

WAN Interface:

Service Provider:

Service Type:

Domain Name:  .

Login Name:  (max. 23 characters)

Password:  (max. 23 characters)

Wildcards

Backup MX

Mail Extender:

<b>Enable Dynamic DNS Account</b>	Check this box to enable the current account. If you did check the box, you will see a check mark appeared on the Active column of the previous web page in step 2).
<b>WAN Interface</b>	Select the WAN interface order to apply settings here.
<b>Service Provider</b>	Select the service provider for the DDNS account.
<b>Service Type</b>	Select a service type (Dynamic, Custom, Static). If you choose Custom, you can modify the domain that is chosen in the Domain Name field.
<b>Domain Name</b>	Type in the domain name that you applied previously. Use the drop down list to choose the desired domain.
<b>Login Name</b>	Type in the login name that you set for applying domain.
<b>Password</b>	Type in the password that you set for applying domain.
<b>Wildcards</b>	It is not supported for all Dynamic DNS providers. Please get more detailed information from its website.
<b>Backup MX</b>	It is not supported for all Dynamic DNS providers. Please get more detailed information from its website.
<b>Mail Extender</b>	It allows you to control the delivery of mails for a given <i>domain</i> or <i>subdomain</i> . The entry you type here can be specified as a secondary mail exchanger. It means that

delivery will be attempted to your host first, and then to the host you specify here if that fails.

4. Click **OK** button to activate the settings. You will see your setting has been saved.

The Wildcard and Backup MX features are not supported for all Dynamic DNS providers. You could get more detailed information from their websites.

### Disable the Function and Clear all Dynamic DNS Accounts

In the DDNS setup menu, uncheck **Enable Dynamic DNS Setup**, and push **Clear All** button to disable the function and clear all accounts from the router.

### Delete a Dynamic DNS Account

In the DDNS setup menu, click the **Index** number you want to delete and then push **Clear All** button to delete the account.

## 3.9.2 Schedule

The Vigor router has a built-in real time clock which can update itself manually or automatically by means of Network Time Protocols (NTP). As a result, you can not only schedule the router to dialup to the Internet at a specified time, but also restrict Internet access to certain hours so that users can connect to the Internet only during certain hours, say, business hours. The schedule is also applicable to other functions.

You have to set your time before set schedule. In **System Maintenance>> Time and Date** menu, press **Inquire Time** button to set the Vigor router's clock to current time of your PC. The clock will reset once if you power down or reset the router. There is another way to set up time. You can inquiry an NTP server (a time server) on the Internet to synchronize the router's clock. This method can only be applied when the WAN connection has been built up.

Applications >> Schedule

Schedule: | [Set to Factory Default](#) |

Index	Status	Index	Status
<a href="#">1.</a>	x	<a href="#">9.</a>	x
<a href="#">2.</a>	x	<a href="#">10.</a>	x
<a href="#">3.</a>	x	<a href="#">11.</a>	x
<a href="#">4.</a>	x	<a href="#">12.</a>	x
<a href="#">5.</a>	x	<a href="#">13.</a>	x
<a href="#">6.</a>	x	<a href="#">14.</a>	x
<a href="#">7.</a>	x	<a href="#">15.</a>	x
<a href="#">8.</a>	x		

Status: v --- Active, x --- Inactive

### Set to Factory Default

Clear all profiles and recover to factory settings.

### Index

Click the number below Index to access into the setting page of schedule.

### Status

Display if this schedule setting is active or inactive.

You can set up to 15 schedules. Then you can apply them to your **Internet Access** or **VPN and Remote Access >> LAN-to-LAN** settings.

To add a schedule, please click any index, say Index No. 1. The detailed settings of the call schedule with index 1 are shown below.

**Index No. 1**

Enable Schedule Setup

Start Date (yyyy-mm-dd)    2000 - 1 - 1

Start Time (hh:mm)        0 : 0

Duration Time (hh:mm)    0 : 0

Action                      Force On

Idle Timeout                0 minute(s).(max. 255, 0 for default)

---

How Often

Once

Weekdays



Sun    Mon    Tue    Wed    Thu    Fri    Sat

OK    Clear    Cancel

- Enable Schedule Setup**        Check to enable the schedule.
- Start Date (yyyy-mm-dd)**    Specify the starting date of the schedule.
- Start Time (hh:mm)**            Specify the starting time of the schedule.
- Duration Time (hh:mm)**        Specify the duration (or period) for the schedule.
- Action**                            Specify which action Call Schedule should apply during the period of the schedule.  
**Force On** -Force the connection to be always on.  
**Force Down** -Force the connection to be always down.  
**Enable Dial-On-Demand** -Specify the connection to be dial-on-demand and the value of idle timeout should be specified in **Idle Timeout** field.  
**Disable Dial-On-Demand** -Specify the connection to be up when it has traffic on the line. Once there is no traffic over idle timeout, the connection will be down and never up again during the schedule.
- Idle Timeout**                    Specify the duration (or period) for the schedule.  
**How often** -Specify how often the schedule will be applied  
**Once** -The schedule will be applied just once  
**Weekdays** -Specify which days in one week should perform the schedule.

**Example**

Suppose you want to control the PPPoE Internet access connection to be always on (Force On) from 9:00 to 18:00 for whole week. Other time the Internet access connection should be disconnected (Force Down).

**Office Hour:**                          **9:00 am**    to        **6:00 pm**

**(Force On)**                      **Mon - Sun**

1. Make sure the PPPoE connection and **Time Setup** is working properly.
2. Configure the PPPoE always on from 9:00 to 18:00 for whole week.

3. Configure the **Force Down** from 18:00 to next day 9:00 for whole week.
4. Assign these two profiles to the PPPoE Internet access profile. Now, the PPPoE Internet connection will follow the schedule order to perform **Force On** or **Force Down** action according to the time plan that has been pre-defined in the schedule profiles.

### 3.9.3 RADIUS

Remote Authentication Dial-In User Service (RADIUS) is a security authentication client/server protocol that supports authentication, authorization and accounting, which is widely used by Internet service providers. It is the most common method of authenticating and authorizing dial-up and tunneled network users.

The built-in RADIUS client feature enables the router to assist the remote dial-in user or a wireless station and the RADIUS server in performing mutual authentication. It enables centralized remote access authentication for network management.

Applications >> RADIUS

#### RADIUS Setup

<input checked="" type="checkbox"/> Enable	
Server IP Address	<input type="text"/>
Destination Port	<input type="text" value="1812"/>
Shared Secret	<input type="text"/>
Confirm Shared Secret	<input type="text"/>

<b>Enable</b>	Check to enable RADIUS client feature
<b>Server IP Address</b>	Enter the IP address of RADIUS server
<b>Destination Port</b>	The UDP port number that the RADIUS server is using. The default value is 1812, based on RFC 2138.
<b>Shared Secret</b>	The RADIUS server and client share a secret that is used to authenticate the messages sent between them. Both sides must be configured to use the same shared secret.
<b>Confirm Shared Secret</b>	Re-type the Shared Secret for confirmation.

### 3.9.4 UPnP

The **UPnP** (Universal Plug and Play) protocol is supported to bring to network connected devices the ease of installation and configuration which is already available for directly connected PC peripherals with the existing Windows 'Plug and Play' system. For NAT routers, the major feature of UPnP on the router is "NAT Traversal". This enables applications inside the firewall to automatically open the ports that they need to pass through a router. It is more reliable than requiring a router to work out by itself which ports need to be opened. Further, the user does not have to manually set up port mappings or a DMZ. **UPnP is available on Windows XP** and the router provides the associated support for MSN Messenger to allow full use of the voice, video and messaging features.

Applications >> UPnP

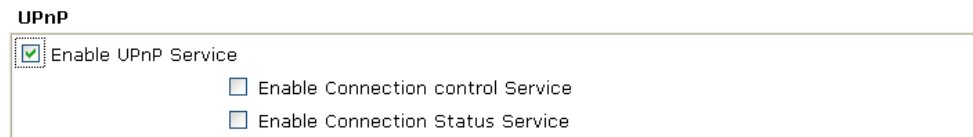

**Note:** If you intend running UPnP service inside your LAN, you should check the appropriate service above to allow control, as well as the appropriate UPnP settings.

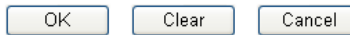

**Enable UPnP Service** Accordingly, you can enable either the **Connection Control Service** or **Connection Status Service**.

After setting **Enable UPnP Service** setting, an icon of **IP Broadband Connection on Router** on Windows XP/Network Connections will appear. The connection status and control status will be able to be activated. The NAT Traversal of UPnP enables the multimedia features of your applications to operate. This has to manually set up port mappings or use other similar methods. The screenshots below show examples of this facility.

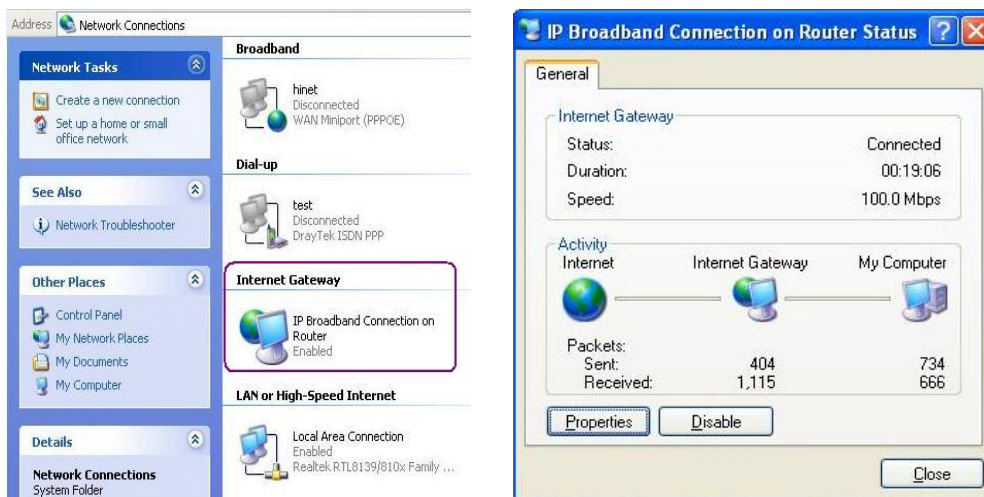

The UPnP facility on the router enables UPnP aware applications such as MSN Messenger to discover what are behind a NAT router. The application will also learn the external IP address and configure port mappings on the router. Subsequently, such a facility forwards packets from the external ports of the router to the internal ports used by the application.

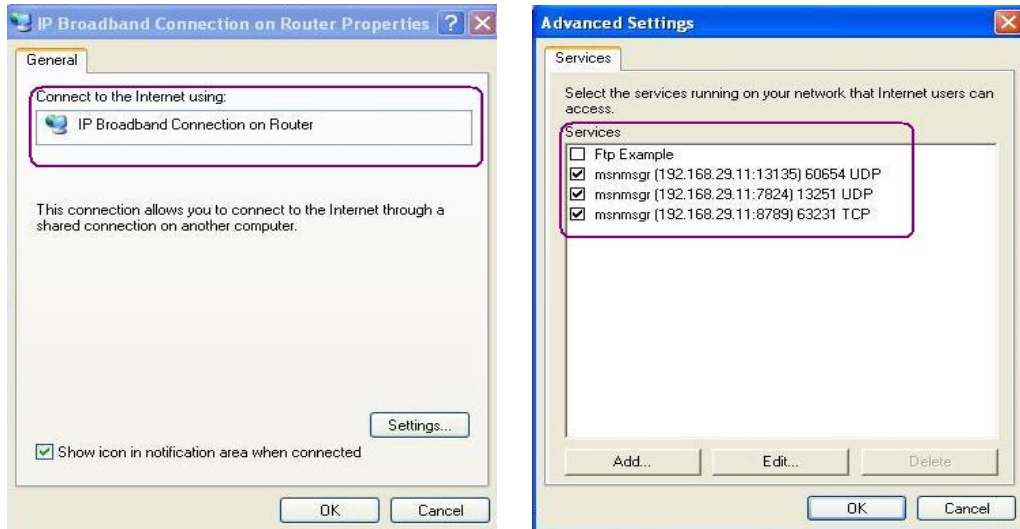

The reminder as regards concern about Firewall and UPnP

### **Can't work with Firewall Software**

Enabling firewall applications on your PC may cause the UPnP function not working properly. This is because these applications will block the accessing ability of some network ports.

### **Security Considerations**

Activating the UPnP function on your network may incur some security threats. You should consider carefully these risks before activating the UPnP function.

- Some Microsoft operating systems have found out the UPnP weaknesses and hence you need to ensure that you have applied the latest service packs and patches.
- Non-privileged users can control some router functions, including removing and adding port mappings.

The UPnP function dynamically adds port mappings on behalf of some UPnP-aware applications. When the applications terminate abnormally, these mappings may not be removed.

### 3.9.5 IGMP

IGMP is the abbreviation of *Internet Group Management Protocol*. It is a communication protocol which is mainly used for managing the membership of Internet Protocol multicast groups. For invoking IGMP Snooping function, you have to check the Enable IGMP Proxy box first for activating the IGMP proxy function.

Applications >> IGMP

**IGMP**

**Enable IGMP Proxy**  
 IGMP Proxy is to act as a multicast proxy for hosts on the LAN side. Enable IGMP Proxy, if you will access any multicast group. But this function **take no affect when Bridge Mode is enabled**.

| [Refresh](#) |

Working Multicast Groups					
Index	Group ID	P1	P2	P3	P4

**Enable IGMP Proxy** Check this box to enable this function. The application of multicast will be executed through WAN port.

**Enable IGMP Snooping** Check this box to enable this function. The application of multicast will be executed for the clients in LAN.

**Group ID** This field displays the ID port for the multicast group. The available range for IGMP starts from 224.0.0.0 to 239.255.255.254.

**P1 to P4** It indicates the LAN port used for the multicast group.

**Refresh** Click this link to renew the working multicast group status.

If you check Enable IGMP Proxy, you will get the following page. All the multicast groups will be listed and all the LAN ports (P1 to P4) are available for use.

Applications >> IGMP

**IGMP**

**Enable IGMP Proxy**  
 IGMP Proxy is to act as a multicast proxy for hosts on the LAN side. Enable IGMP Proxy, if you will access any multicast group. But this function **take no affect when Bridge Mode is enabled**.

| [Refresh](#) |

Working Multicast Groups					
Index	Group ID	P1	P2	P3	P4
1.	224.0.0.9	v	v	v	v

### 3.9.6 Wake on LAN

A PC client on LAN can be woken up by the router it connects. When a user wants to wake up a specified PC through the router, he/she must type correct MAC address of the specified PC on this web page of **Wake on LAN** of this router.

In addition, such PC must have installed a network card supporting WOL function. By the way, WOL function must be set as “Enable” on the BIOS setting.

Application >> Wake on LAN

Wake on LAN

**Note:** Wake on LAN integrates with **Bind IP to MAC** function, only binded PCs can wake up through IP.

Wake by:

IP Address:

MAC Address:  :  :  :  :  :

**Result**

**Wake by**

Two types provide for you to wake up the binded IP. If you choose Wake by MAC Address, you have to type the correct MAC address of the host in MAC Address boxes. If you choose Wake by IP Address, you have to choose the correct IP address.

Wake by:

**IP Address**

The IP addresses that have been configured in LAN>>Bind IP to MAC will be shown in this drop down list. Choose the IP address from the drop down list that you want to wake up.

**MAC Address**

Type any one of the MAC address of the binded PCs.

**Wake Up**

Click this button to wake up the selected IP. See the following figure. The result will be shown on the box.

Application >> Wake on LAN

Wake on LAN

**Note:** Wake on LAN integrates with **Bind IP to MAC** function, only binded PCs can wake up through IP.

Wake by:

IP Address:

MAC Address:  :  :  :  :  :

**Result**

Send command to client done.



## 3.10 VPN and Remote Access

A Virtual Private Network (VPN) is the extension of a private network that encompasses links across shared or public networks like the Internet. In short, by VPN technology, you can send data between two computers across a shared or public network in a manner that emulates the properties of a point-to-point private link.

Below shows the menu items for VPN and Remote Access.



### 3.10.1 Remote Access Control

Enable the necessary VPN service as you need. If you intend to run a VPN server inside your LAN, you should disable the VPN service of Vigor Router to allow VPN tunnel pass through, as well as the appropriate NAT settings, such as DMZ or open port.

VPN and Remote Access >> Remote Access Control Setup

#### Remote Access Control Setup

<input checked="" type="checkbox"/>	Enable PPTP VPN Service
<input checked="" type="checkbox"/>	Enable IPSec VPN Service
<input checked="" type="checkbox"/>	Enable L2TP VPN Service
<input type="checkbox"/>	Enable ISDN Dial-In

**Note:** If you intend running a VPN server inside your LAN, you should uncheck the appropriate protocol above to allow pass-through, as well as the appropriate NAT settings.

OK Clear Cancel

The Vigor router will not accept the ISDN dial-in connection if the box of **Enable ISDN Dial-in** is not checked.

### 3.10.2 PPP General Setup

This submenu only applies to PPP-related VPN connections, such as PPTP, L2TP, L2TP over IPSec.

VPN and Remote Access >> PPP General Setup

**PPP General Setup**

<b>PPP/MP Protocol</b>		<b>IP Address Assignment for Dial-In Users</b>	
Dial-In PPP Authentication	<input type="text" value="PAP or CHAP"/>	Start IP Address	<input type="text" value="192.168.1.200"/>
Dial-In PPP Encryption (MPPE)	<input type="text" value="Optional MPPE"/>		
Mutual Authentication (PAP)	<input type="radio"/> Yes <input checked="" type="radio"/> No		
Username	<input type="text"/>		
Password	<input type="text"/>		

#### Dial-In PPP Authentication PAP Only

Select this option to force the router to authenticate dial-in users with the PAP protocol.

#### PAP or CHAP

Selecting this option means the router will attempt to authenticate dial-in users with the CHAP protocol first. If the dial-in user does not support this protocol, it will fall back to use the PAP protocol for authentication.

#### Dial-In PPP Encryption (MPPE Optional MPPE)

This option represents that the MPPE encryption method will be optionally employed in the router for the remote dial-in user. If the remote dial-in user does not support the MPPE encryption algorithm, the router will transmit “no MPPE encrypted packets”. Otherwise, the MPPE encryption scheme will be used to encrypt the data.

**Require MPPE (40/128bits)** - Selecting this option will force the router to encrypt packets by using the MPPE encryption algorithm. In addition, the remote dial-in user will use 40-bit to perform encryption prior to using 128-bit for encryption. In other words, if 128-bit MPPE encryption method is not available, then 40-bit encryption scheme will be applied to encrypt the data.

**Maximum MPPE** - This option indicates that the router will use the MPPE encryption scheme with maximum bits (128-bit) to encrypt the data.

#### Mutual Authentication (PAP)

The Mutual Authentication function is mainly used to communicate with other routers or clients who need bi-directional authentication in order to provide stronger security, for example, Cisco routers. So you should enable this function when your peer router requires mutual authentication. You should further specify the **User Name** and **Password** of the mutual authentication peer.

#### Start IP Address

Enter a start IP address for the dial-in PPP connection. You should choose an IP address from the local private network.

For example, if the local private network is 192.168.1.0/255.255.255.0, you could choose 192.168.1.200 as the Start IP Address. But, you have to notice that the first two IP addresses of 192.168.1.200 and 192.168.1.201 are reserved for ISDN remote dial-in user.

### 3.10.3 IPSec General Setup

In **IPSec General Setup**, there are two major parts of configuration.

There are two phases of IPSec.

- Phase 1: negotiation of IKE parameters including encryption, hash, Diffie-Hellman parameter values, and lifetime to protect the following IKE exchange, authentication of both peers using either a Pre-Shared Key or Digital Signature (x.509). The peer that starts the negotiation proposes all its policies to the remote peer and then remote peer tries to find a highest-priority match with its policies. Eventually to set up a secure tunnel for IKE Phase 2.
- Phase 2: negotiation IPSec security methods including Authentication Header (AH) or Encapsulating Security Payload (ESP) for the following IKE exchange and mutual examination of the secure tunnel establishment.

There are two encapsulation methods used in IPSec, **Transport** and **Tunnel**. The **Transport** mode will add the AH/ESP payload and use original IP header to encapsulate the data payload only. It can just apply to local packet, e.g., L2TP over IPSec. The **Tunnel** mode will not only add the AH/ESP payload but also use a new IP header (Tunneled IP header) to encapsulate the whole original IP packet.

Authentication Header (AH) provides data authentication and integrity for IP packets passed between VPN peers. This is achieved by a keyed one-way hash function to the packet to create a message digest. This digest will be put in the AH and transmitted along with packets. On the receiving side, the peer will perform the same one-way hash on the packet and compare the value with the one in the AH it receives.

Encapsulating Security Payload (ESP) is a security protocol that provides data confidentiality and protection with optional authentication and replay detection service.

#### VPN and Remote Access >> IPSec General Setup

##### VPN IKE/IPSec General Setup

Dial-in Set up for Remote Dial-in users and Dynamic IP Client (LAN to LAN).

**IKE Authentication Method**

Pre-Shared Key

Confirm Pre-Shared Key

**IPSec Security Method**

Medium (AH)  
Data will be authentic, but will not be encrypted.

High (ESP)     DES     3DES     AES  
Data will be encrypted and authentic.

**IKE Authentication Method** This usually applies to those are remote dial-in user or node (LAN-to-LAN) which uses dynamic IP address and IPSec-related VPN connections such as L2TP over IPSec and IPSec tunnel.

**Pre-Shared Key** -Currently only support Pre-Shared Key authentication.

**Pre-Shared Key-** Specify a key for IKE authentication  
**Confirm Pre-Shared Key-** Confirm the pre-shared key.

**IPSec Security Method**

**Medium** - Authentication Header (AH) means data will be authenticated, but not be encrypted. By default, this option is active.

**High** - Encapsulating Security Payload (ESP) means payload (data) will be encrypted and authenticated. You may select encryption algorithm from Data Encryption Standard (DES), Triple DES (3DES), and AES.

**3.10.4 IPSec Peer Identity**

To use digital certificate for peer authentication in either LAN-to-LAN connection or Remote User Dial-In connection, here you may edit a table of peer certificate for selection. As shown below, the router provides **100** entries of digital certificates for peer dial-in users.

VPN and Remote Access >> IPSec Peer Identity

X509 Peer ID Accounts:

[Set to Factory Default](#)

Index	Name	Status	Index	Name	Status
<a href="#">1.</a>	???	×	<a href="#">17.</a>	???	×
<a href="#">2.</a>	???	×	<a href="#">18.</a>	???	×
<a href="#">3.</a>	???	×	<a href="#">19.</a>	???	×
<a href="#">4.</a>	???	×	<a href="#">20.</a>	???	×
<a href="#">5.</a>	???	×	<a href="#">21.</a>	???	×
<a href="#">6.</a>	???	×	<a href="#">22.</a>	???	×
<a href="#">7.</a>	???	×	<a href="#">23.</a>	???	×
<a href="#">8.</a>	???	×	<a href="#">24.</a>	???	×
<a href="#">9.</a>	???	×	<a href="#">25.</a>	???	×
<a href="#">10.</a>	???	×	<a href="#">26.</a>	???	×
<a href="#">11.</a>	???	×	<a href="#">27.</a>	???	×
<a href="#">12.</a>	???	×	<a href="#">28.</a>	???	×
<a href="#">13.</a>	???	×	<a href="#">29.</a>	???	×
<a href="#">14.</a>	???	×	<a href="#">30.</a>	???	×
<a href="#">15.</a>	???	×	<a href="#">31.</a>	???	×
<a href="#">16.</a>	???	×	<a href="#">32.</a>	???	×

<< [1-32](#) | [33-64](#) | [65-96](#) | [97-100](#) >>

[Next](#) >>

**Set to Factory Default**

Click it to clear all indexes.

**Index**

Click the number below Index to access into the setting page of IPSec Peer Identity.

**Name**

Display the profile name of that index.

Click each index to edit one peer digital certificate. There are three security levels of digital signature authentication: Fill each necessary field to authenticate the remote peer. The following explanation will guide you to fill all the necessary fields.

**Profile Index : 1**

**Profile Name**

Enable this account

---

**Accept Any Peer ID**

---

**Accept Subject Alternative Name**

Type

IP

---

**Accept Subject Name**

Country (C)

State (ST)

Location (L)

Organization (O)

Organization Unit (OU)

Common Name (CN)

Email (E)

- Profile Name** Type in a name in this file.
- Accept Any Peer ID** Click to accept any peer regardless of its identity.
- Accept Subject Alternative Name** Click to check one specific field of digital signature to accept the peer with matching value. The field can be **IP Address**, **Domain**, or **E-mail** address. The box under the Type will appear according to the type you select and ask you to fill in corresponding setting.
- Accept Subject Name** Click to check the specific fields of digital signature to accept the peer with matching value. The field includes **Country (C)**, **State (ST)**, **Location (L)**, **Organization (O)**, **Organization Unit (OU)**, **Common Name (CN)**, and **Email (E)**.

### 3.10.5 Remote Dial-in User

You can manage remote access by maintaining a table of remote user profile, so that users can be authenticated to dial-in via ISDN or build the VPN connection. You may set parameters including specified connection peer ID, connection type (VPN connection - including PPTP, IPsec Tunnel, and L2TP by itself or over IPsec) and corresponding security methods, etc.

The router provides **100** access accounts for dial-in users. Besides, you can extend the user accounts to the RADIUS server through the built-in RADIUS client function. The following figure shows the summary table.

VPN and Remote Access >> Remote Dial-in User

Remote Access User Accounts: | [Set to Factory Default](#) |

Index	User	Status	Index	User	Status
<a href="#">1.</a>	???	X	<a href="#">17.</a>	???	X
<a href="#">2.</a>	???	X	<a href="#">18.</a>	???	X
<a href="#">3.</a>	???	X	<a href="#">19.</a>	???	X
<a href="#">4.</a>	???	X	<a href="#">20.</a>	???	X
<a href="#">5.</a>	???	X	<a href="#">21.</a>	???	X
<a href="#">6.</a>	???	X	<a href="#">22.</a>	???	X
<a href="#">7.</a>	???	X	<a href="#">23.</a>	???	X
<a href="#">8.</a>	???	X	<a href="#">24.</a>	???	X
<a href="#">9.</a>	???	X	<a href="#">25.</a>	???	X
<a href="#">10.</a>	???	X	<a href="#">26.</a>	???	X
<a href="#">11.</a>	???	X	<a href="#">27.</a>	???	X
<a href="#">12.</a>	???	X	<a href="#">28.</a>	???	X
<a href="#">13.</a>	???	X	<a href="#">29.</a>	???	X
<a href="#">14.</a>	???	X	<a href="#">30.</a>	???	X
<a href="#">15.</a>	???	X	<a href="#">31.</a>	???	X
<a href="#">16.</a>	???	X	<a href="#">32.</a>	???	X

<< [1-32](#) | [33-64](#) | [65-96](#) | [97-100](#) >> [Next](#) >>

**Set to Factory Default**

Click to clear all indexes.

**Index**

Click the number below Index to access into the setting page of Remote Dial-in User.

**User**

Display the username for the specific dial-in user of the LAN-to-LAN profile. The symbol ??? represents that the profile is empty.

**Status**

Display the access state of the specific dial-in user. The symbol V and X represent the specific dial-in user to be active and inactive, respectively.

Click each index to edit one remote user profile. **Each Dial-In Type requires you to fill the different corresponding fields on the right.** If the fields gray out, it means you may leave it untouched. The following explanation will guide you to fill all the necessary fields.

Index No. 1

<p><b>User account and Authentication</b></p> <p><input type="checkbox"/> Enable this account</p> <p>Idle Timeout <input type="text" value="300"/> second(s)</p>		<p>Username <input style="width: 100px;" type="text" value="???"/></p> <p>Password <input style="width: 100px;" type="password"/></p>
<p><b>Allowed Dial-In Type</b></p> <p><input checked="" type="checkbox"/> ISDN</p> <p><input checked="" type="checkbox"/> PPTP</p> <p><input checked="" type="checkbox"/> IPsec Tunnel</p> <p><input checked="" type="checkbox"/> L2TP with IPsec Policy <input style="width: 50px;" type="text" value="None"/></p> <p><input checked="" type="checkbox"/> SSL Tunnel</p> <p><input type="checkbox"/> Specify Remote Node</p> <p>Remote Client IP or Peer ISDN Number <input style="width: 100px;" type="text"/></p> <p>or Peer ID <input style="width: 100px;" type="text"/></p> <p>Netbios Naming Packet <input checked="" type="radio"/> Pass <input type="radio"/> Block</p>		<p><b>IKE Authentication Method</b></p> <p><input checked="" type="checkbox"/> Pre-Shared Key</p> <p>IKE Pre-Shared Key <input style="width: 100px;" type="text"/></p> <p><input type="checkbox"/> Digital Signature (X.509)</p> <p><input style="width: 50px;" type="text" value="None"/></p>
<p><b>SSL VPN</b></p> <p><b>Set SSL Web Proxy</b></p>		<p><b>IPsec Security Method</b></p> <p><input checked="" type="checkbox"/> Medium (AH)</p> <p>High (ESP)</p> <p><input checked="" type="checkbox"/> DES <input checked="" type="checkbox"/> 3DES <input checked="" type="checkbox"/> AES</p> <p>Local ID <input style="width: 100px;" type="text"/> (optional)</p>
		<p><b>Callback Function</b></p> <p><input type="checkbox"/> Check to enable Callback function</p> <p><input type="checkbox"/> Specify the callback number</p> <p>Callback Number <input style="width: 100px;" type="text"/></p> <p><input checked="" type="checkbox"/> Check to enable Callback Budget Control</p> <p>Callback Budget <input type="text" value="30"/> minute(s)</p>

**Enable this account**

Check the box to enable this function.

**Idle Timeout-** If the dial-in user is idle over the limitation of the timer, the router will drop this connection. By default, the Idle Timeout is set to 300 seconds.

**ISDN**

Allow the remote ISDN dial-in connection. You can further set up Callback function below. You should set the User Name and Password of remote dial-in user below. This feature is for *i* model only.

**PPTP**

Allow the remote dial-in user to make a PPTP VPN connection through the Internet. You should set the User Name and Password of remote dial-in user below

**IPsec Tunnel**

Allow the remote dial-in user to make an IPsec VPN connection through Internet.

**L2TP**

Allow the remote dial-in user to make a L2TP VPN connection through the Internet. You can select to use L2TP alone or with IPsec. Select from below:

**None** - Do not apply the IPsec policy. Accordingly, the VPN connection employed the L2TP without IPsec policy can be viewed as one pure L2TP connection.

**Nice to Have** - Apply the IPsec policy first, if it is applicable during negotiation. Otherwise, the dial-in VPN connection becomes one pure L2TP connection.

**Must** -Specify the IPsec policy to be definitely applied on the L2TP connection.

## SSL Tunnel

It allows the remote dial-in user to make an SSL VPN Tunnel connection through Internet, suitable for the application through network accessing (e.g., PPTP/L2TP/IPSec)

If you check this box, the function of SSL Tunnel for this account will be activated immediately.

VPN and Remote Access >> Remote Dial-in User

Index No. 1

<b>User account and Authentication</b> <input type="checkbox"/> Enable this account Idle Timeout: <input type="text" value="300"/> second(s)	Username: <input type="text" value="???"/> Password: <input type="password"/>
<b>Allowed Dial-In Type</b> <input checked="" type="checkbox"/> ISDN <input checked="" type="checkbox"/> PPTP <input checked="" type="checkbox"/> IPsec Tunnel <input checked="" type="checkbox"/> L2TP with IPsec Policy: <input type="text" value="None"/> <input checked="" type="checkbox"/> <b>SSL Tunnel</b> <input type="checkbox"/> Specify Remote Node Remote Client IP or Peer ISDN Number: <input type="text"/> or Peer ID: <input type="text"/>	<b>IKE Authentication Method</b> <input checked="" type="checkbox"/> Pre-Shared Key IKE Pre-Shared Key: <input type="text"/> <input type="checkbox"/> Digital Signature (X.509) None <b>IPsec Security Method</b> <input checked="" type="checkbox"/> Medium (AH) High (ESP) <input checked="" type="checkbox"/> DES <input checked="" type="checkbox"/> 3DES <input checked="" type="checkbox"/> AES Local ID: <input type="text"/> (optional)

Netbios Naming Packet:  Pass  Block

To check if SSL Tunnel is activated or not, please open Draytek SSL VPN portal interface. From the web page, you will see the message to indicate the SSL Tunnel is activated.

**DrayTek**

Provide SSL VPN

Home **SSL Tunnel** [logout]

Use SSL Tunnel:

Warning: Keep your browser open to maintain the connection. If you reload your browser, Vigor SSL Tunnel will disconnect.

Change default route to the remote gateway

Connect

## Specify Remote Node

**Check the checkbox**-You can specify the IP address of the remote dial-in user, ISDN number or peer ID (used in IKE aggressive mode).

**Uncheck the checkbox**-This means the connection type you select above will apply the authentication methods and security methods in the **general settings**.

## Netbios Naming Packet

**Pass** – click it to have an inquiry for data transmission between the hosts located on both sides of VPN Tunnel while connecting.

**Block** – When there is conflict occurred between the hosts on both sides of VPN Tunnel in connecting, such function can block data transmission of Netbios Naming Packet inside the tunnel.

## SSL VPN

It allows the remote dial-in user to access internal web over SSL VPN, suitable for the application through web only (e.g., HTTP). Click **Set SSL Web Proxy** to set profiles.

If you have set several profiles beforehand, you can check SSL Web Proxy and choose the one(s) you need as SSL VPN.



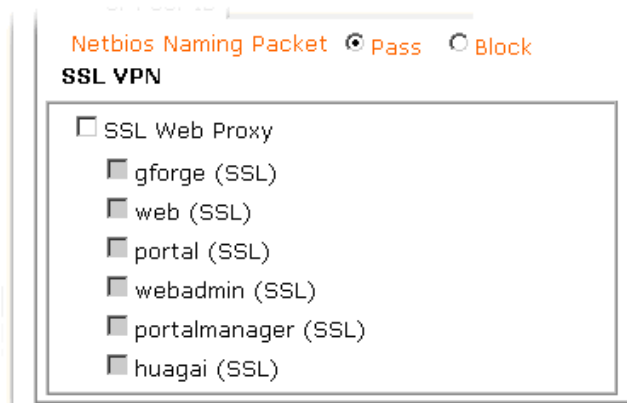

To check if SSL Web Proxy is activated or not, please open Draytek SSL VPN portal interface. From the web page, you will see the message to indicate that you have the privilege for the SSL Web Proxy.



**Set SSL Web Proxy** – If you haven't set any SSL VPN web proxy profiles, you will a link here. Click this link to access into the configuration page of SSL VPN.

**Note:** SSL VPN can be applied in browser (e.g., IE) which supports ActivateX only.

**User Name** This field is applicable when you select ISDN, PPTP or L2TP with or without IPSec policy above.

**Password** This field is applicable when you select ISDN, PPTP or L2TP with or without IPSec policy above.

**IKE Authentication Method** This group of fields is applicable for IPSec Tunnels and L2TP with IPSec Policy when you specify the IP address of the remote node. The only exception is Digital Signature (X.509) can be set when you select IPSec tunnel either with or without specify the IP address of the remote node.

**Pre-Shared Key** - Check the box of Pre-Shared Key to invoke this function and type in the required characters (1-63) as the pre-shared key.

**Digital Signature (X.509)** – Check the box of Digital Signature to invoke this function and Select one predefined Profiles set in the **VPN and Remote Access >>IPSec Peer Identity**.

**IPSec Security Method** This group of fields is a must for IPSec Tunnels and L2TP with IPSec Policy when you specify the remote node. Check the Medium, DES, 3DES or AES box as the security method.

**Medium-Authentication Header (AH)** means data will be authenticated, but not be encrypted. By default, this option is invoked. You can uncheck it to disable it.

**High-Encapsulating Security Payload (ESP)** means payload (data) will be encrypted and authenticated. You may select encryption algorithm from Data Encryption Standard (DES), Triple DES (3DES), and AES.

**Local ID** - Specify a local ID to be used for Dial-in setting in the LAN-to-LAN Profile setup. This item is optional and can be used only in IKE aggressive mode.

### Callback Function

The callback function provides a callback service only for the ISDN dial-in user (for *i* model only). The remote user will be charged the connection fee by the telecom.

**Check to enable Callback function**-Enables the callback function.

**Specify the callback number**-The option is for extra security. Once enabled, the router will ONLY call back to the specified Callback Number.

**Check to enable callback budget control**-By default, the callback function has a time restriction. Once the callback budget has been exhausted, the callback mechanism will be disabled automatically.

**Callback Budget (Unit: minutes)**- Specify the time budget for the dial-in user. The budget will be decreased automatically per callback connection.

### 3.10.6 LAN to LAN

Here you can manage LAN-to-LAN connections by maintaining a table of connection profiles. You may set parameters including specified connection direction (dial-in or dial-out), connection peer ID, connection type (VPN connection - including PPTP, IPsec Tunnel, and L2TP by itself or over IPsec) and corresponding security methods, etc.

The router provides up to **100** profiles, which also means supporting **100** VPN tunnels simultaneously. The following figure shows the summary table.

VPN and Remote Access >> LAN to LAN

LAN-to-LAN Profiles:

[Set to Factory Default](#)

Index	Name	Status	Index	Name	Status
<a href="#">1.</a>	???	×	<a href="#">17.</a>	???	×
<a href="#">2.</a>	???	×	<a href="#">18.</a>	???	×
<a href="#">3.</a>	???	×	<a href="#">19.</a>	???	×
<a href="#">4.</a>	???	×	<a href="#">20.</a>	???	×
<a href="#">5.</a>	???	×	<a href="#">21.</a>	???	×
<a href="#">6.</a>	???	×	<a href="#">22.</a>	???	×
<a href="#">7.</a>	???	×	<a href="#">23.</a>	???	×
<a href="#">8.</a>	???	×	<a href="#">24.</a>	???	×
<a href="#">9.</a>	???	×	<a href="#">25.</a>	???	×
<a href="#">10.</a>	???	×	<a href="#">26.</a>	???	×
<a href="#">11.</a>	???	×	<a href="#">27.</a>	???	×
<a href="#">12.</a>	???	×	<a href="#">28.</a>	???	×
<a href="#">13.</a>	???	×	<a href="#">29.</a>	???	×
<a href="#">14.</a>	???	×	<a href="#">30.</a>	???	×
<a href="#">15.</a>	???	×	<a href="#">31.</a>	???	×
<a href="#">16.</a>	???	×	<a href="#">32.</a>	???	×

<< [1-32](#) | [33-64](#) | [65-96](#) | [97-100](#) >>

[Next](#) >>

## Set to Factory Default

Click to clear all indexes.

## Name

Indicate the name of the LAN-to-LAN profile. The symbol ??? represents that the profile is empty.

## Status

Indicate the status of individual profiles. The symbol V and X represent the profile to be active and inactive, respectively.

Click each index to edit each profile and you will get the following page. Each LAN-to-LAN profile includes 4 subgroups. If the fields gray out, it means you may leave it untouched. The following explanations will guide you to fill all the necessary fields.

For the web page is too long, we divide the page into several sections for explanation.

VPN and Remote Access >> LAN to LAN

Profile Index : 1

### 1. Common Settings

Profile Name <input type="text" value="???"/>	Call Direction <input checked="" type="radio"/> Both <input type="radio"/> Dial-Out <input type="radio"/> Dial-In
<input type="checkbox"/> Enable this profile	<input type="checkbox"/> Always on
VPN Connection Through: <input type="text" value="WAN1 First"/>	Idle Timeout <input type="text" value="300"/> second(s)
Netbios Naming Packet <input checked="" type="radio"/> Pass <input type="radio"/> Block	<input type="checkbox"/> Enable PING to keep alive
	PING to the IP <input type="text"/>

### 2. Dial-Out Settings

<b>Type of Server I am calling</b> <input checked="" type="radio"/> ISDN <input type="radio"/> PPTP <input type="radio"/> IPSec Tunnel <input type="radio"/> L2TP with IPSec Policy <input type="text" value="None"/>	Link Type <input type="text" value="64k bps"/> Username <input type="text" value="???"/> Password <input type="text"/> PPP Authentication <input type="text" value="PAP/CHAP"/> VJ Compression <input checked="" type="radio"/> On <input type="radio"/> Off
Dial Number for ISDN or Server IP/Host Name for VPN. (such as 5551234, draytek.com or 123.45.67.89) <input type="text"/>	<b>IKE Authentication Method</b> <input checked="" type="radio"/> Pre-Shared Key IKE Pre-Shared Key <input type="text"/> <input type="radio"/> Digital Signature(X.509) <input type="text" value="None"/>
	<b>IPSec Security Method</b> <input checked="" type="radio"/> Medium(AH) <input type="radio"/> High(ESP) <input type="text" value="DES without Authentication"/> <input type="button" value="Advanced"/>
	Index(1-15) in <b>Schedule</b> Setup: <input type="text"/> , <input type="text"/> , <input type="text"/> , <input type="text"/>
	<b>Callback Function (CBCP)</b> <input type="checkbox"/> Require Remote to Callback <input type="checkbox"/> Provide ISDN Number to Remote

## Profile Name

Specify a name for the profile of the LAN-to-LAN connection.

## Enable this profile

Check here to activate this profile.

## VPN Connection Through

Use the drop down menu to choose a proper WAN interface for this profile. This setting is useful for dial-out only.

VPN Connection Through:

- WAN1 First
- WAN1 Only
- WAN2 First
- WAN2 Only

**WAN1 First** - While connecting, the router will use WAN1 as the first channel for VPN connection. If WAN1 fails, the router will use another WAN interface instead.

**WAN1 Only** - While connecting, the router will use WAN1 as the only channel for VPN connection.

**WAN2 First** - While connecting, the router will use WAN2 as the first channel for VPN connection. If WAN2 fails, the router will use another WAN interface instead.

**WAN2 Only** - While connecting, the router will use WAN2 as the only channel for VPN connection.

**Netbios Naming Packet**

**Pass** – click it to have an inquiry for data transmission between the hosts located on both sides of VPN Tunnel while connecting.

**Block** – When there is conflict occurred between the hosts on both sides of VPN Tunnel in connecting, such function can block data transmission of Netbios Naming Packet inside the tunnel.

**Call Direction**

Specify the allowed call direction of this LAN-to-LAN profile.

**Both**:-initiator/responder

**Dial-Out**- initiator only

**Dial-In**- responder only.

**Always On or Idle Timeout**

**Always On**-Check to enable router always keep VPN connection.

**Idle Timeout**: The default value is 300 seconds. If the connection has been idled over the value, the router will drop the connection.

**Enable PING to keep alive**

This function is to help the router to determine the status of IPSec VPN connection, especially useful in the case of abnormal VPN IPSec tunnel disruption. For details, please refer to the note below. Check to enable the transmission of PING packets to a specified IP address.

**PING to the IP**

Enter the IP address of the remote host that located at the other-end of the VPN tunnel.

**Enable PING to Keep Alive** is used to handle abnormal IPSec VPN connection disruption. It will help to provide the state of a VPN connection for router's judgment of redial.

Normally, if any one of VPN peers wants to disconnect the connection, it should follow a serial of packet exchange procedure to inform each other. However, if the remote peer disconnect without notice, Vigor router will by no where to know this situation. To resolve this dilemma, by continuously sending PING packets to the remote host, the Vigor router can know the true existence of this VPN connection and react accordingly. This is independent of DPD (dead peer detection).

**ISDN**

Build ISDN LAN-to-LAN connection to remote network. You should set up Link Type and identity like User Name and Password for the authentication of remote server. You can further set up Callback (CBCP) function below. This feature is useful for *i* model only.

<b>PPTP</b>	Build a PPTP VPN connection to the server through the Internet. You should set the identity like User Name and Password below for the authentication of remote server.
<b>IPSec Tunnel</b>	Build an IPSec VPN connection to the server through Internet.
<b>L2TP with ...</b>	Build a L2TP VPN connection through the Internet. You can select to use L2TP alone or with IPSec. Select from below: <b>None:</b> Do not apply the IPSec policy. Accordingly, the VPN connection employed the L2TP without IPSec policy can be viewed as one pure L2TP connection. <b>Nice to Have:</b> Apply the IPSec policy first, if it is applicable during negotiation. Otherwise, the dial-out VPN connection becomes one pure L2TP connection. <b>Must:</b> Specify the IPSec policy to be definitely applied on the L2TP connection.
<b>Server IP/Host Name for..</b>	You can specify the IP address of the remote dial-out user.
<b>User Name</b>	This field is applicable when you select ISDN, PPTP or L2TP with or without IPSec policy above.
<b>Password</b>	This field is applicable when you select ISDN, PPTP or L2TP with or without IPSec policy above.
<b>PPP Authentication</b>	This field is applicable when you select ISDN, PPTP or L2TP with or without IPSec policy above. PAP/CHAP is the most common selection due to wild compatibility.
<b>VJ compression</b>	This field is applicable when you select ISDN, PPTP or L2TP with or without IPSec policy above. VJ Compression is used for TCP/IP protocol header compression. Normally set to <b>Yes</b> to improve bandwidth utilization.
<b>IKE Authentication Method</b>	This group of fields is applicable for IPSec Tunnels and L2TP with IPSec Policy. <b>Pre-Shared Key</b> -Input 1-63 characters as pre-shared key. <b>Digital Signature (X.509)</b> - Select one predefined Profiles set in the <b>VPN and Remote Access &gt;&gt;IPSec Peer Identity</b> .
<b>IPSec Security Method</b>	This group of fields is a must for IPSec Tunnels and L2TP with IPSec Policy. <b>Medium (AH - Authentication Header)</b> means data will be authenticated, but not be encrypted. By default, this option is active. <b>High (ESP-Encapsulating Security Payload)-</b> means payload (data) will be encrypted and authenticated. Select from below: <b>DES without Authentication</b> -Use DES encryption algorithm and not apply any authentication scheme. <b>DES with Authentication</b> -Use DES encryption algorithm and apply MD5 or SHA-1 authentication algorithm. <b>3DES without Authentication</b> -Use triple DES encryption algorithm and not apply any authentication scheme. <b>3DES with Authentication</b> -Use triple DES encryption algorithm and apply MD5 or SHA-1 authentication algorithm. <b>AES without Authentication</b> -Use AES encryption algorithm and not apply any authentication scheme.

**AES with Authentication**-Use AES encryption algorithm and apply MD5 or SHA-1 authentication algorithm.

## Advanced

Specify mode, proposal and key life of each IKE phase, Gateway etc.

The window of advance setup is shown as below:

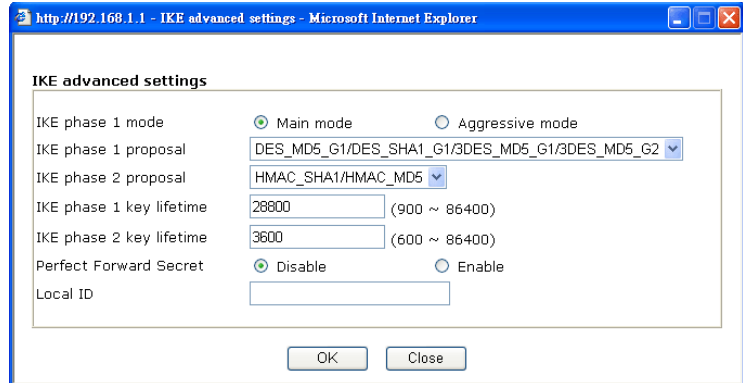

**IKE phase 1 mode** -Select from **Main** mode and **Aggressive** mode. The ultimate outcome is to exchange security proposals to create a protected secure channel. **Main** mode is more secure than **Aggressive** mode since more exchanges are done in a secure channel to set up the IPSec session. However, the **Aggressive** mode is faster. The default value in Vigor router is Main mode.

**IKE phase 1 proposal**-To propose the local available authentication schemes and encryption algorithms to the VPN peers, and get its feedback to find a match. Two combinations are available for Aggressive mode and nine for **Main** mode. We suggest you select the combination that covers the most schemes.

**IKE phase 2 proposal**-To propose the local available algorithms to the VPN peers, and get its feedback to find a match. Three combinations are available for both modes. We suggest you select the combination that covers the most algorithms.

**IKE phase 1 key lifetime**-For security reason, the lifetime of key should be defined. The default value is 28800 seconds.

You may specify a value in between 900 and 86400 seconds.

**IKE phase 2 key lifetime**-For security reason, the lifetime of key should be defined. The default value is 3600 seconds.

You may specify a value in between 600 and 86400 seconds.

**Perfect Forward Secret (PFS)**-The IKE Phase 1 key will be reused to avoid the computation complexity in phase 2. The default value is inactive this function.

**Local ID**-In **Aggressive** mode, Local ID is on behalf of the IP address while identity authenticating with remote VPN server. The length of the ID is limited to 47 characters.

## Callback Function (for *i* models only)

The callback function provides a callback service as a part of PPP suite only for the ISDN dial-in user. The router owner will be charged the connection fee by the telecom.

**Require Remote to Callback**-Enable this to let the router to require the remote peer to callback for the connection afterwards.

**Provide ISDN Number to Remote**-In the case that the

remote peer requires the Vigor router to callback, the local ISDN number will be provided to the remote peer. Check here to allow the Vigor router to send the ISDN number to the remote router. This feature is useful for *i* model only.

### 3. Dial-In Settings

<b>Allowed Dial-In Type</b> <input checked="" type="checkbox"/> ISDN <input checked="" type="checkbox"/> PPTP <input checked="" type="checkbox"/> IPsec Tunnel <input checked="" type="checkbox"/> L2TP with IPsec Policy <span>None</span>		Username <input type="text" value="???"/> Password <input type="text"/> VJ Compression <input checked="" type="radio"/> On <input type="radio"/> Off
<input type="checkbox"/> Specify ISDN CLID or Remote VPN Gateway Peer ISDN Number or Peer VPN Server IP <input type="text"/> or Peer ID <input type="text"/>		<b>IKE Authentication Method</b> <input checked="" type="checkbox"/> Pre-Shared Key IKE Pre-Shared Key <input type="text"/> <input type="checkbox"/> Digital Signature(X.509) <span>None</span>
		<b>IPsec Security Method</b> <input checked="" type="checkbox"/> Medium (AH) High (ESP) <input checked="" type="checkbox"/> DES <input checked="" type="checkbox"/> 3DES <input checked="" type="checkbox"/> AES
		<b>Callback Function (CBCP)</b> <input type="checkbox"/> Enable Callback Function <input type="checkbox"/> Use the Following Number to Callback Callback Number <input type="text"/> Callback Budget <input type="text" value="0"/> minute(s)

### 4. TCP/IP Network Settings

My WAN IP <input type="text" value="0.0.0.0"/> Remote Gateway IP <input type="text" value="0.0.0.0"/> Remote Network IP <input type="text" value="0.0.0.0"/> Remote Network Mask <input type="text" value="255.255.255.0"/> <input type="button" value="More"/>	RIP Direction <span>Disable</span> From first subnet to remote network, you have to do <input type="button" value="Route"/> <input type="checkbox"/> Change default route to this VPN tunnel ( Only single WAN supports this )
---	---

#### Allowed Dial-In Type

Determine the dial-in connection with different types.

#### ISDN

Allow the remote ISDN LAN-to-LAN connection. You should set the User Name and Password of remote dial-in user below. This feature is useful for *i* model only. In addition, you can further set up Callback function below.

#### PPTP

Allow the remote dial-in user to make a PPTP VPN connection through the Internet. You should set the User Name and Password of remote dial-in user below.

#### IPsec Tunnel

Allow the remote dial-in user to trigger an IPsec VPN connection through Internet.

#### L2TP

Allow the remote dial-in user to make a L2TP VPN connection through the Internet. You can select to use L2TP alone or with IPsec. Select from below:

**None-** Do not apply the IPSec policy. Accordingly, the VPN connection employed the L2TP without IPSec policy can be viewed as one pure L2TP connection.

**Nice to Have-** Apply the IPSec policy first, if it is applicable during negotiation. Otherwise, the dial-in VPN connection becomes one pure L2TP connection.

**Must-** Specify the IPSec policy to be definitely applied on the L2TP connection.

**Specify CLID or Remote VPN Gateway**

You can specify the IP address of the remote dial-in user or peer ID (should be the same with the ID setting in dial-in type) by checking the box. Enter Peer ISDN number if you select ISDN above (This feature is useful for *i* model only.). Also, you should further specify the corresponding security methods on the right side.

If you uncheck the checkbox, the connection type you select above will apply the authentication methods and security methods in the general settings.

**User Name**

This field is applicable when you select ISDN, PPTP or L2TP with or without IPSec policy above.

**Password**

This field is applicable when you select ISDN, PPTP or L2TP with or without IPSec policy above.

**VJ Compression**

VJ Compression is used for TCP/IP protocol header compression. This field is applicable when you select ISDN, PPTP or L2TP with or without IPSec policy above.

**IKE Authentication Method**

This group of fields is applicable for IPSec Tunnels and L2TP with IPSec Policy when you specify the IP address of the remote node. The only exception is Digital Signature (X.509) can be set when you select IPSec tunnel either with or without specify the IP address of the remote node.

**Pre-Shared Key** - Check the box of Pre-Shared Key to invoke this function and type in the required characters (1-63) as the pre-shared key.

**Digital Signature (X.509)** – Check the box of Digital Signature to invoke this function and select one predefined Profiles set in the **VPN and Remote Access >>IPSec Peer Identity**.

**IPSec Security Method**

This group of fields is a must for IPSec Tunnels and L2TP with IPSec Policy when you specify the remote node.

**Medium-** Authentication Header (AH) means data will be authenticated, but not be encrypted. By default, this option is active.

**High-** Encapsulating Security Payload (ESP) means payload (data) will be encrypted and authenticated. You may select encryption algorithm from Data Encryption Standard (DES), Triple DES (3DES), and AES.

**Callback Function**

The callback function provides a callback service only for the ISDN LAN-to-LAN connection (this feature is useful for *i* model only). The remote user will be charged the connection fee by the telecom.

**Check to enable Callback function**-Enables the callback function.



**Callback number**-The option is for extra security. Once enabled, the router will ONLY call back to the specified Callback Number.

**Callback budget**- By default, the callback function has limitation of callback period. Once the callback budget is exhausted, the function will be disabled automatically.

**Callback Budget (Unit: minutes)**- Specify the time budget for the dial-in user. The budget will be decreased automatically per callback connection. The default value 0 means no limitation of callback period.

**My WAN IP**

This field is only applicable when you select ISDN, PPTP or L2TP with or without IPSec policy above. The default value is 0.0.0.0, which means the Vigor router will get a PPP IP address from the remote router during the IPCP negotiation phase. If the PPP IP address is fixed by remote side, specify the fixed IP address here. Do not change the default value if you do not select ISDN, PPTP or L2TP.

**Remote Gateway IP**

This field is only applicable when you select ISDN, PPTP or L2TP with or without IPSec policy above. The default value is 0.0.0.0, which means the Vigor router will get a remote Gateway PPP IP address from the remote router during the IPCP negotiation phase. If the PPP IP address is fixed by remote side, specify the fixed IP address here. Do not change the default value if you do not select ISDN, PPTP or L2TP.

**Remote Network IP/  
Remote Network Mask**

Add a static route to direct all traffic destined to this Remote Network IP Address/Remote Network Mask through the VPN connection. For IPSec, this is the destination clients IDs of phase 2 quick mode.

**More**

Add a static route to direct all traffic destined to more Remote Network IP Addresses/ Remote Network Mask through the VPN connection. This is usually used when you find there are several subnets behind the remote VPN router.

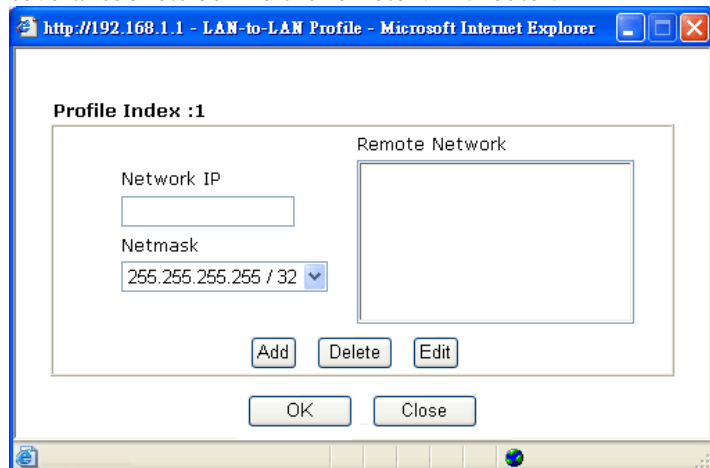

**RIP Direction**

The option specifies the direction of RIP (Routing Information Protocol) packets. You can enable/disable one of direction here. Herein, we provide four options: TX/RX Both, TX Only, RX Only, and Disable.

**From first subnet to  
remote network, you**

If the remote network only allows you to dial in with single

**have to do**

IP, please choose **NAT**, otherwise choose **Route**.

**Change default route to this VPN tunnel (Only single WAN supports this )**

Check this box to change the default route with this VPN tunnel. Be aware that this setting is available only for one WAN interface is enabled. It is not available when both WAN interfaces are enabled.

### 3.10.7 Connection Management

You can find the summary table of all VPN connections. You may disconnect any VPN connection by clicking **Drop** button. You may also aggressively Dial-out by using Dial-out Tool and clicking **Dial** button.

VPN and Remote Access >> Connection Management

Dial-out Tool Refresh Seconds : 10

**VPN Connection Status** Page No.

Current Page: 1

VPN	Type	Remote IP	Virtual Network	Tx Pkts	Tx Rate	Rx Pkts	Rx Rate	UpTime

xxxxxxx : Data is encrypted.  
xxxxxxx : Data isn't encrypted.

**Dial**

Click this button to execute dial out function.

**Refresh Seconds**

Choose the time for refresh the dial information among 5, 10, and 30.

**Refresh**

Click this button to refresh the whole connection status.

## 3.11 Certificate Management

A digital certificate works as an electronic ID, which is issued by a certification authority (CA). It contains information such as your name, a serial number, expiration dates etc., and the digital signature of the certificate-issuing authority so that a recipient can verify that the certificate is real. Here Vigor router support digital certificates conforming to standard X.509.

Any entity wants to utilize digital certificates should first request a certificate issued by a CA server. It should also retrieve certificates of other trusted CA servers so it can authenticate the peer with certificates issued by those trusted CA servers.

Here you can manage generate and manage the local digital certificates, and set trusted CA certificates. Remember to adjust the time of Vigor router before using the certificate so that you can get the correct valid period of certificate.

Below shows the menu items for Certificate Management.

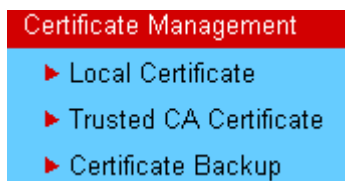

### 3.11.1 Local Certificate

Certificate Management >> Local Certificate

#### X509 Local Certificate Configuration

Name	Subject	Status	Modify	
Local	---	---	<input type="button" value="View"/>	<input type="button" value="Delete"/>

X509 Local Certificate

**Generate**

Click this button to open **Generate Certificate Request** window.

**Generate Certificate Request**

**Subject Alternative Name**

Type: IP Address (dropdown)  
 IP:

---

**Subject Name**

Country (C):   
 State (ST):   
 Location (L):   
 Organization (O):   
 Organization Unit (OU):   
 Common Name (CN):   
 Email (E):

---

**Key Type**: RSA (dropdown)  
**Key Size**: 1024 Bit (dropdown)

Type in all the information that the window request. Then click **Generate** again.

**Import**

Click this button to import a saved file as the certification information.

**Refresh**

Click this button to refresh the information listed below.

**View**

Click this button to view the detailed settings for certificate request.

After clicking **Generate**, the generated information will be displayed on the window below:

**X509 Local Certificate Configuration**

Name	Subject	Status	Modify	
Local	/C=TW/O=Draytek/OU=RD/emailA...	Requesting	<input type="button" value="View"/>	<input type="button" value="Delete"/>

**X509 Local Certificate Request**

```

-----BEGIN CERTIFICATE REQUEST-----
MIIBjzCB+QIBADBQMqswCQYDVQQGEwJUVzEQMA4GA1UEChMHRRHJheXRlayZELMAkG
A1UECxmCUkQxIjAgBgkqhkiG9wOBCQEWES3N1cnZpY2VAZHJheXRlay5jb20wgZSw
DQYJKoZIhvcNAQEBBQADgYOAAMIGJAoGBAMemQ68+eOu+ESZ37c1TP51CRDFuxgxw
K89UJEeq1lh7rUYhrfgFjo7kZ0fQTPWjqU/vv3vmwOEnkg16mntzq9tBMdfi2djG
cDIzQh7H9MOmpP0qrPu0cga0Ete1oaLhgV1MovrojR6OXNPABq6kYr4NYLMh1bFH
MDkjEpdMQARpAgMBAAGgADANBgkqhkiG9w0BAQUFAAOBGBWphus100n9rZ8y2C2
egi0n39FoAPathPmqH2oAYFGeDMbCHGUY4vHdkQo7R0bVtKkqs17D12hPESHGSO
P/D4zKQiJLTKSm8+3gX3ZdRq+IjpsruzZTTBPBMR93PhP3USUYTrBLolpNVQCgqj
jaquLf4Xpb0VVqOq8a4UbtXENw==
-----END CERTIFICATE REQUEST-----
    
```

### 3.11.2 Trusted CA Certificate

Trusted CA certificate lists three sets of trusted CA certificate.

Certificate Management >> Trusted CA Certificate

#### X509 Trusted CA Certificate Configuration

Name	Subject	Status	Modify	
Trusted CA-1	---	---	<input type="button" value="View"/>	<input type="button" value="Delete"/>
Trusted CA-2	---	---	<input type="button" value="View"/>	<input type="button" value="Delete"/>
Trusted CA-3	---	---	<input type="button" value="View"/>	<input type="button" value="Delete"/>

To import a pre-saved trusted CA certificate, please click **IMPORT** to open the following window. Use **Browse...** to find out the saved text file. Then click Import. The one you imported will be listed on the Trusted CA Certificate window. Then click **Import** to use the pre-saved file.

Certificate Management >> Trusted CA Certificate

#### Import X509 Trusted CA Certificate

Select a trusted CA certificate file.

Click [Import](#) to upload the certification.

For viewing each trusted CA certificate, click **View** to open the certificate detail information window. If you want to delete a CA certificate, choose the one and click **Delete** to remove all the certificate information.

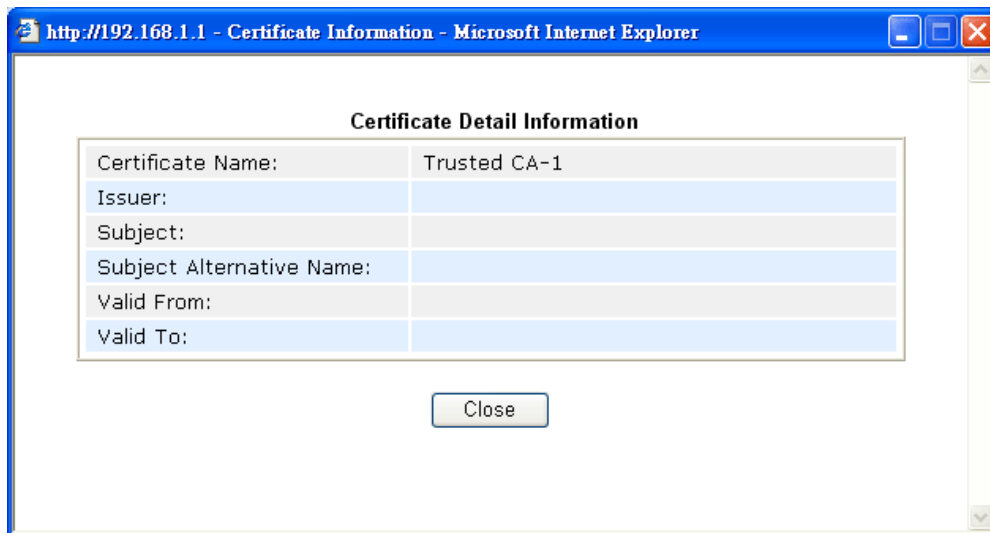

### 3.11.3 Certificate Backup

Local certificate and Trusted CA certificate for this router can be saved within one file. Please click **Backup** on the following screen to save them. If you want to set encryption password for these certificates, please type characters in both fields of **Encrypt password** and **Retype password**.

Also, you can use **Restore** to retrieve these two settings to the router whenever you want.

Certificate Management >> Certificate Backup

**Certificate Backup / Restoration**

**Backup**

Encrypt password:

Retype password:

Click  to download certificates to your local PC as a file.

---

**Restoration**

Select a backup file to restore.

Decrypt password:

Click  to upload the file.

### 3.12 VoIP

Voice over IP network (VoIP) enables you to use your broadband Internet connection to make toll quality voice calls over the Internet.

There are many different call signaling protocols, methods by which VoIP devices can talk to each other. The most popular protocols are SIP, MGCP, Megaco and H.323. These protocols are not all compatible with each other (except via a soft-switch server).

The Vigor V models support the SIP protocol as this is an ideal and convenient deployment for the ITSP (Internet Telephony Service Provider) and softphone and is widely supported. SIP is an end-to-end, signaling protocol that establishes user presence and mobility in VoIP structure. Every one who wants to talk using his/her SIP Uniform Resource Identifier, "SIP Address". The standard format of SIP URI is

**sip: user:password @ host: port**

Some fields may be optional in different use. In general, "host" refers to a domain. The "userinfo" includes the user field, the password field and the @ sign following them. This is very similar to a URL so some may call it "SIP URL". SIP supports peer-to-peer direct calling and also calling via a SIP proxy server (a role similar to the gatekeeper in H.323 networks), while the MGCP protocol uses client-server architecture, the calling scenario being very similar to the current PSTN/ISDN network.

After a call is setup, the voice streams transmit via RTP (Real-Time Transport Protocol). Different codecs (methods to compress and encode the voice) can be embedded into RTP packets. Vigor V models provide various codecs, including G.711 A/ $\mu$ -law, G.723, G.726 and G.729 A & B. Each codec uses a different bandwidth and hence provides different levels of voice quality. The more bandwidth a codec uses the better the voice quality, however the codec used must be appropriate for your Internet bandwidth.

Usually there will be two types of calling scenario, as illustrated below:

- **Calling via SIP Servers**

First, the Vigor V models of yours will have to register to a SIP Registrar by sending

registration messages to validate. Then, both parties' SIP proxies will forward the sequence of messages to caller to establish the session.

If you both register to the same SIP Registrar, then it will be illustrated as below:

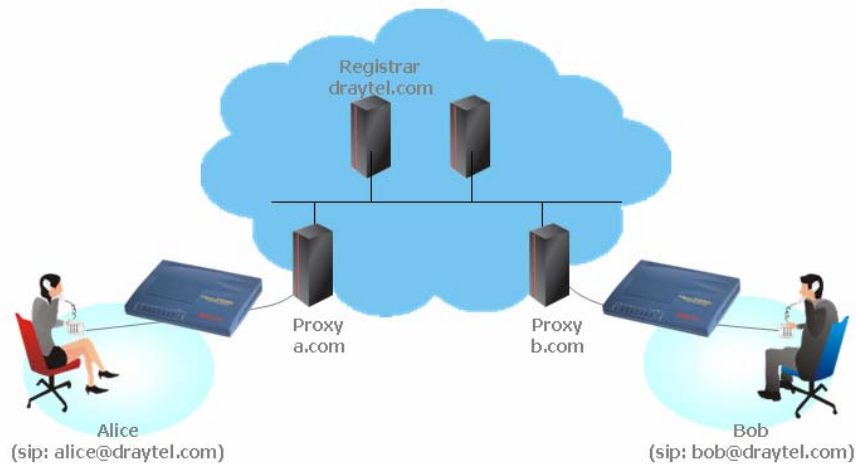

The major benefit of this mode is that you don't have to memorize your friend's IP address, which might change very frequently if it's dynamic. Instead of that, you will only have to use **dial plan** or directly dial your friend's **account name** if you are with the same SIP Registrar. Please refer to the **section 4.5.1**.

- **Peer-to-Peer**

Before calling, you have to know your friend's IP Address. The Vigor VoIP Routers will build connection between each other. Please refer to the **section 4.5.2**.



Our Vigor V models firstly apply efficient codecs designed to make the best use of available bandwidth, but Vigor V models also equip with automatic QoS assurance. QoS Assurance assists to assign high priority to voice traffic via Internet. You will always have the required inbound and outbound bandwidth that is prioritized exclusively for Voice traffic over Internet but you just get your data a little slower and it is tolerable for data traffic.

VoIP
▶ DialPlan
▶ SIP Accounts
▶ Phone Settings
▶ Status

### 3.12.1 DialPlan

This page allows you to set phone book and digit map for the VoIP function. Click the **Phone Book** and **Digit Map** links on the page to access into next pages for dialplan settings.

## DialPlan Configuration

<a href="#">Phone Book</a> <a href="#">Digit Map</a> <a href="#">Call Barring</a> <a href="#">Regional</a>
---

## Phone Book

In this section, you can set your VoIP contacts in the “phonebook”. It can help you to make calls quickly and easily by using “speed-dial” **Phone Number**. There are total 60 index entries in the phonebook for you to store all your friends and family members’ SIP addresses. **Loop through** and **Backup Phone Number** will be displayed if you are using VigorPro5300 VS for setting the phone book.

## Phone Book

Index	Phone number	Display Name	SIP URL	Loop through	Backup Phone Number	Status
<a href="#">1.</a>				None		x
<a href="#">2.</a>				None		x
<a href="#">3.</a>				None		x
<a href="#">4.</a>				None		x
<a href="#">5.</a>				None		x
<a href="#">6.</a>				None		x
<a href="#">7.</a>				None		x
<a href="#">8.</a>				None		x
<a href="#">9.</a>				None		x
<a href="#">10.</a>				None		x
<a href="#">11.</a>				None		x
<a href="#">12.</a>				None		x
<a href="#">13.</a>				None		x
<a href="#">14.</a>				None		x
<a href="#">15.</a>				None		x
<a href="#">16.</a>				None		x
<a href="#">17.</a>				None		x
<a href="#">18.</a>				None		x
<a href="#">19.</a>				None		x
<a href="#">20.</a>				None		x

<< [1-20](#) | [20-40](#) | [40-60](#) >>[Next](#) >>

Status: v --- Active, x --- Inactive, ? --- Empty

Click any index number to display the dial plan setup page.



VoIP >> DialPlan Setup

Phone Book Index No. 1

<input checked="" type="checkbox"/> Enable		
Phone Number	<input type="text" value="688"/>	
Display Name	<input type="text" value="david"/>	
SIP URL	<input type="text" value="8201"/>	<input type="text" value="@iptel.org"/>

**Enable**

Click this to enable this entry.

**Phone Number**

The speed-dial number of this index. This can be any number you choose, using digits **0-9** and **\*** .

**Display Name**

The Caller-ID that you want to be displayed on your friend's screen. This let your friend can easily know who's calling without memorizing lots of SIP URL Address.

**SIP URL**

Enter your friend's SIP Address

This page will differ for different models. Below is a sample page obtained from VigorPro5300 VS<sub>n</sub>. The selection of **Loop through** and **Backup Phone Number** is only available for 2930VS<sub>n</sub> model.

VoIP >> DialPlan Setup

Phone Book Index No. 1

<input checked="" type="checkbox"/> Enable		
Phone Number	<input type="text" value="1"/>	
Display Name	<input type="text" value="Polly"/>	
SIP URL	<input type="text" value="1112"/>	<input type="text" value="@fwd.pulver.com "/>
Loop through	<input type="button" value="None"/>	
Backup Phone Number	<input type="text"/>	

**Enable**

Click this to enable this entry.

**Phone Number**

The speed-dial number of this index. This can be any number you choose, using digits **0-9** and **\*** .

**Display Name**

The Caller-ID that you want to be displayed on your friend's screen. This let your friend can easily know who's calling without memorizing lots of SIP URL Address.

**SIP URL**

Enter your friend's SIP Address

**Loop through**

For the model of VigorPro5300 VS<sub>n</sub>, the selection should be as the following:

Loop through

None	▼
None	
ISDN2-TE	

**Backup Phone Number**

When the VoIP phone is obstructs or the Internet breaks down for some reasons, the backup phone will be dialed out to

replace the VoIP phone number. At this time, the phone call will be changed from VoIP phone into PSTN call according to the loop through direction chosen. Note that, during the phone switch, the blare of phone will appear for a short time. And when the VoIP phone is switched into the PSTN phone, the telecom co. might charge you for the connection fee. Please type in backup phone number (PSTN number) for this VoIP phone setting.

## Digit Map

For the convenience of user, this page allows users to edit prefix number for the SIP account with adding number, stripping number or replacing number. It is used to help user having a quick and easy way to dial out through VoIP interface.

VoIP >> DialPlan Setup

### Digit Map Setup

#	Enable	Prefix Number	Mode	OP Number	Min Len	Max Len	Interface
1	<input type="checkbox"/>		None		0	0	ISDN2-TE
2	<input type="checkbox"/>		None		0	0	ISDN2-TE
3	<input type="checkbox"/>		None		0	0	ISDN2-TE
4	<input type="checkbox"/>		None		0	0	ISDN2-TE
5	<input type="checkbox"/>		None		0	0	ISDN2-TE
6	<input type="checkbox"/>		None		0	0	ISDN2-TE
7	<input type="checkbox"/>		None		0	0	ISDN2-TE
8	<input type="checkbox"/>		None		0	0	ISDN2-TE
9	<input type="checkbox"/>		None		0	0	ISDN2-TE
10	<input type="checkbox"/>		None		0	0	ISDN2-TE
11	<input type="checkbox"/>		None		0	0	ISDN2-TE
12	<input type="checkbox"/>		None		0	0	ISDN2-TE
13	<input type="checkbox"/>		None		0	0	ISDN2-TE
14	<input type="checkbox"/>		None		0	0	ISDN2-TE
15	<input type="checkbox"/>		None		0	0	ISDN2-TE
16	<input type="checkbox"/>		None		0	0	ISDN2-TE
17	<input type="checkbox"/>		None		0	0	ISDN2-TE
18	<input type="checkbox"/>		None		0	0	ISDN2-TE
19	<input type="checkbox"/>		None		0	0	ISDN2-TE
20	<input type="checkbox"/>		None		0	0	ISDN2-TE

**Note:** Min Len and Max Len should be between 0~11.

OK Cancel

#### Enable

Check this box to invoke this setting.

#### Prefix Number

The phone number set here is used to add, strip, or replace the OP number.

#### Mode

**None** - No action.

**Add** - When you choose this mode, the OP number will be added with the prefix number for calling out through the specific VoIP interface.

**Strip** - When you choose this mode, the OP number will be deleted by the prefix number for calling out through the specific VoIP interface. Take the above picture (Prefix Table Setup web page) as an example, the OP number of 886 will be deleted completely for the prefix number is set with 886.

**Replace** - When you choose this mode, the OP number will be replaced by the prefix number for calling out through the specific VoIP interface. Take the above picture (Prefix Table Setup web page) as an example, the prefix number of 03 will be replaced by 8863. For example: dial number of “031111111” will be changed to “8863111111” and sent to SIP server.

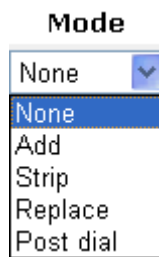

**OP Number**

The front number you type here is the first part of the account number that you want to execute special function (according to the chosen mode) by using the prefix number.

**Min Len**

Set the minimal length of the dial number for applying the prefix number settings. Take the above picture (Prefix Table Setup web page) as an example, if the dial number is between 7 and 9, that number can apply the prefix number settings here.

**Max Len**

Set the maximum length of the dial number for applying the prefix number settings.

**Interface**

Choose the one that you want to enable the prefix number settings from the saved SIP accounts. Please set up one SIP account first to make this interface available.

**Call Barring**

Call barring is used to block phone calls that are not welcomed.

Call Barring Setup | [Set to Factory Default](#) |

Index	Call Direction	Barring Type	Barring Number/URL/URI	Interface	Schedule	Status
1.						x
2.						x
3.						x
4.						x
5.						x
6.						x
7.						x
8.						x
9.						x
10.						x

<< 1-10 | 11-20 >>

[Next](#) >>

**Advanced:**  
[Block Anonymous](#)  
[Block Unknown Domain](#)  
[Block IP Address](#)

Click any index number to display the dial plan setup page.

Call Barring Index No. 1

Enable

Call Direction:

Barring Type:

Specific URI/URL:

Interface:

Index(1-15) in **Schedule** Setup:  ,  ,  ,

**Enable**

Click this to enable this entry.

**Call Direction**

Determine the direction for the phone call, IN – incoming call, OUT-outgoing call, IN & OUT – both incoming and outgoing calls.

IN

IN

OUT

IN & OUT

**Barring Type**

Determine the type of the VoIP phone call, URI/URL or number.

Specific URI/URL

Specific URI/URL

Specific Number

**Specific URI/URL or Specific Number** - This field will be changed based on the type you selected for barring Type.

## Interface

“All” means all the phone calls (including ISDN & PSTN) will be blocked with such mechanism.

”ISDN” means only ISDN phone call will be blocked with such mechanism.



A dropdown menu with a blue arrow pointing down. The menu is open, showing two options: 'All' (highlighted in blue) and 'ISDN'.

## Index (1-15) in Schedule

Enter the index of schedule profiles to control the call barring according to the preconfigured schedules. Refer to section **3.9.2 Schedule** for detailed configuration.

Additionally, you can set advanced settings for call barring such as **Block Anonymous**, **Block Unknown Domain** or **Block IP Address**. Simply click the relational links to open the web page.

For **Block Anonymous** – this function can block the incoming calls without caller ID on the interface (Phone 1 or Phone 2 or both) specified in the following window. Such controlling also can be done based on preconfigured schedules.

### VoIP >> DialPlan Setup

#### Call Barring Block Anonymous

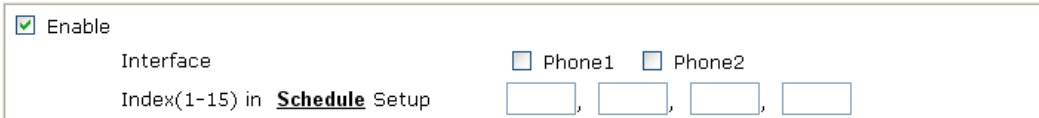

Enable

Interface  Phone1  Phone2

Index(1-15) in **Schedule** Setup , , ,

**Note:**Block the incoming calls which do not have the caller ID.



OK Cancel

For **Block Unknown Domain** – this function can block incoming calls from unrecognized domain that is not specified in SIP accounts. Such controlling also can be done based on preconfigured schedules.

### VoIP >> DialPlan Setup

#### Call Barring Block Unknown Domain

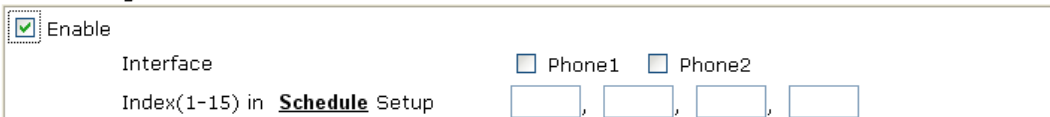

Enable

Interface  Phone1  Phone2

Index(1-15) in **Schedule** Setup , , ,

**Note:**If the domain of the incoming call is different from the domain found in SIP accounts, the call should be blocked.



OK Cancel

For **Block IP Address** – this function can block incoming calls coming from IP address. Such controlling also can be done based on preconfigured schedules.

## VoIP >> DialPlan Setup

### Call Barring Block IP Address

<input checked="" type="checkbox"/> Enable
Interface <input type="checkbox"/> Phone1 <input type="checkbox"/> Phone2
Index(1-15) in <b>Schedule</b> Setup <input type="text"/> , <input type="text"/> , <input type="text"/> , <input type="text"/>

**Note:** The incoming calls by means of IP dialing (e.g. #192\*168\*1\*1#) should be blocked.

OK Cancel

## Regional

This page allows you to process incoming or outgoing phone calls by regional. Default values (common used in most areas) will be shown on this web page. You *can change* the number based on the region that the router is placed.

### VoIP >> DialPlan Setup

Regional		Set to Factory Default	
Last Call Return [Miss]:	<input type="text" value="*69"/>		
Last Call Return [In]:	<input type="text" value="*12"/>	Last Call Return [Out]:	<input type="text" value="*14"/>
Call Forward [All] [Act]:	<input type="text" value="*72+number+#"/>	Call Forward [Deact]:	<input type="text" value="*73+#"/>
Call Forward [Busy] [Act]:	<input type="text" value="*90+number+#"/>	Call Forward [No Ans] [Act]:	<input type="text" value="*92+number+#"/>
Do Not Disturb [Act]:	<input type="text" value="*78"/> +#	Do Not Disturb [Deact]:	<input type="text" value="*79"/> +#
Hide caller ID [Act]:	<input type="text" value="*67"/> +#	Hide caller ID [Deact]:	<input type="text" value="*68"/> +#
Call Waiting [Act]:	<input type="text" value="*56"/> +#	Call Waiting [Deact]:	<input type="text" value="*57"/> +#
Block Anonymous [Act]:	<input type="text" value="*77"/> +#	Block Anonymous [Deact]:	<input type="text" value="*87"/> +#
Block Unknow Domain [Act]:	<input type="text" value="*40"/> +#	Block Unknow Domain [Deact]:	<input type="text" value="*04"/> +#
Block IP Calls [Act]:	<input type="text" value="*50"/> +#	Block IP Calls [Deact]:	<input type="text" value="*05"/> +#
Block Last Calls [Act]:	<input type="text" value="*60"/> +#		

OK Cancel

### Last Call Return [Miss]

Sometimes, people might miss some phone calls. Please dial number typed in this field to know where the last phone call comes from and call back to that one.

### Last Call Return [In]

You have finished an incoming phone call, however you want to call back again for some reason. Please dial number typed in this field to call back to that one.

### Last Call Return [Out]

Dial the number typed in this field to call the previous outgoing phone call again.

### Call Forward [All][Act]

Dial the number typed in this field to forward all the incoming calls to the specified place.

### Call Forward [Deact]

Dial the number typed in this field to release the call forward function.

<b>Call Forward [Busy][Act]</b>	Dial the number typed in this field to forward all the incoming calls to the specified place while the phone is busy.
<b>Call Forward [No Ans][Act]</b>	Dial the number typed in this field to forward all the incoming calls to the specified place while there is no answer of the connected phone.
<b>Do Not Disturb [Act]</b>	Dial the number typed in this field to invoke the function of DND.
<b>Do Not Disturb [Deact]</b>	Dial the number typed in this field to release the DND function.
<b>Hide caller ID [Act]</b>	Dial the number typed in this field to make your phone number (ID) not displayed on the display panel of remote end.
<b>Hide caller ID [Deact]</b>	Dial the number typed in this field to release this function.
<b>Call Waiting [Act]</b>	Dial the number typed in this field to make all the incoming calls waiting for your answer.
<b>Call Waiting [Deact]</b>	Dial the number typed in this field to release this function.
<b>Block Anonymous[Act]</b>	Dial the number typed in this field to block all the incoming calls with unknown ID.
<b>Block Anonymous[Deact]</b>	Dial the number typed in this field to release this function.
<b>Block Unknown Domain [Act]</b>	Dial the number typed in this field to block all the incoming calls from unknown domain.
<b>Block Unknown Domain [Deact]</b>	Dial the number typed in this field to release this function.
<b>Block IP Calls [Act]</b>	Dial the number typed in this field to block all the incoming calls from IP address.
<b>Block IP Calls [Deact]</b>	Dial the number typed in this field to release this function.
<b>Block Last Calls [Act]</b>	Dial the number typed in this field to block the last incoming phone call.

### 3.12.2 SIP Accounts

In this section, you set up your own SIP settings. When you apply for an account, your SIP service provider will give you an **Account Name** or user name, **SIP Registrar**, **Proxy**, and **Domain name**. (The last three might be the same in some case). Then you can tell your folks your SIP Address as in **Account Name@ Domain name**

As Vigor VoIP Router is turned on, it will first register with Registrar using AuthorizationUser@Domain/Realm. After that, your call will be bypassed by SIP Proxy to the destination using AccountName@Domain/Realm as identity.

SIP Accounts List

Refresh

Index	Profile	Domain/Realm	Proxy	Account Name	Ring Port	Status
1				change_me	<input type="checkbox"/> Phone1 <input type="checkbox"/> Phone2 <input type="checkbox"/> ISDN1-S0    Any ▾ <input type="checkbox"/> ISDN2-TE	-
2				change_me	<input type="checkbox"/> Phone1 <input type="checkbox"/> Phone2 <input type="checkbox"/> ISDN1-S0    Any ▾ <input type="checkbox"/> ISDN2-TE	-
3				change_me	<input type="checkbox"/> Phone1 <input type="checkbox"/> Phone2 <input type="checkbox"/> ISDN1-S0    Any ▾ <input type="checkbox"/> ISDN2-TE	-
4				change_me	<input type="checkbox"/> Phone1 <input type="checkbox"/> Phone2 <input type="checkbox"/> ISDN1-S0    Any ▾ <input type="checkbox"/> ISDN2-TE	-
5				change_me	<input type="checkbox"/> Phone1 <input type="checkbox"/> Phone2 <input type="checkbox"/> ISDN1-S0    Any ▾ <input type="checkbox"/> ISDN2-TE	-
6				change_me	<input type="checkbox"/> Phone1 <input type="checkbox"/> Phone2 <input type="checkbox"/> ISDN1-S0    Any ▾ <input type="checkbox"/> ISDN2-TE	-
7				change_me	<input type="checkbox"/> Phone1 <input type="checkbox"/> Phone2 <input type="checkbox"/> ISDN1-S0    Any ▾ <input type="checkbox"/> ISDN2-TE	-
8				change_me	<input type="checkbox"/> Phone1 <input type="checkbox"/> Phone2 <input type="checkbox"/> ISDN1-S0    Any ▾ <input type="checkbox"/> ISDN2-TE	-
9				change_me	<input type="checkbox"/> Phone1 <input type="checkbox"/> Phone2 <input type="checkbox"/> ISDN1-S0    Any ▾ <input type="checkbox"/> ISDN2-TE	-
10				change_me	<input type="checkbox"/> Phone1 <input type="checkbox"/> Phone2 <input type="checkbox"/> ISDN1-S0    Any ▾ <input type="checkbox"/> ISDN2-TE	-
11				change_me	<input type="checkbox"/> Phone1 <input type="checkbox"/> Phone2 <input type="checkbox"/> ISDN1-S0    Any ▾ <input type="checkbox"/> ISDN2-TE	-
12				change_me	<input type="checkbox"/> Phone1 <input type="checkbox"/> Phone2 <input type="checkbox"/> ISDN1-S0    Any ▾ <input type="checkbox"/> ISDN2-TE	-

R: success registered on SIP server  
 -: fail to register on SIP server

NAT Traversal Setting

STUN Server:	<input type="text"/>
External IP:	<input type="text"/>
SIP PING Interval:	<input type="text" value="150"/> sec

OK

**Index**

Click this link to access into next page for setting SIP account.

**Profile**

Display the profile name of the account.



<b>Domain/Realm</b>	Display the domain name or IP address of the SIP registrar server.
<b>Proxy</b>	Display the domain name or IP address of the SIP proxy server.
<b>Account Name</b>	Display the account name of SIP address before @.
<b>Ring Port</b>	Specify which port will ring when receiving a phone call. Set Phone1, Phone2, ISDN1-S0 or ISDN-TE as the default ring port for the SIP account. If you choose Phone1, Phone2 or ISDN1-S0, the ISDN2-TE selection will be dimmed, vice versa. There are ten internal lines with numbers (30 – 39) offered for <b>ISDN-S0</b> . You can specify any one of them as ring port for specified SIP account. By the way, ISDN-S0 can be used by mapping with MSN numbers.
<b>STUN Server</b>	Type in the IP address or domain of the STUN server.
<b>External IP</b>	Type in the gateway IP address.
<b>SIP PING interval</b>	The default value is 150 (sec). It is useful for a Nortel server NAT Traversal Support.
<b>Status</b>	Show the status for the corresponding SIP account. <b>R</b> means such account is registered on SIP server successfully. <b>–</b> means the account is failed to register on SIP server.

**VoIP >> SIP Accounts**

**SIP Account Index No. 1**

Profile Name	<input type="text"/>	(11 char max.)
Register via	None <input type="button" value="v"/> <input type="checkbox"/> Call without Registration	
SIP Port	<input type="text" value="5060"/>	
Domain/Realm	<input type="text"/>	(63 char max.)
Proxy	<input type="text"/>	(63 char max.)
	<input type="checkbox"/> Act as outbound proxy	
Display Name	<input type="text"/>	(23 char max.)
Account Number/Name	<input type="text" value="change_me"/>	(63 char max.)
	<input type="checkbox"/> Authentication ID	<input type="text"/>
Password	<input type="text"/>	(63 char max.)
Expiry Time	1 hour <input type="button" value="v"/> <input type="text" value="3600"/> sec	
NAT Traversal Support	None <input type="button" value="v"/>	
Ring Port	<input type="checkbox"/> Phone1 <input type="checkbox"/> Phone2 <input type="checkbox"/> ISDN1-S0 <input type="button" value="v"/> Any <input type="checkbox"/> ISDN2-TE	
Ring Pattern	<input type="button" value="v"/> 1	

OK Cancel

<b>Profile Name</b>	Assign a name for this profile for identifying. You can type similar name with the domain. For example, if the domain name is <i>draytel.org</i> , then you might set <i>draytel-1</i> in this field.
<b>Register via</b>	If you want to make VoIP call without register personal information, please choose <b>None</b> and check the box to achieve the goal. Some SIP server allows user to use VoIP function without registering. For such server, please check the box of <b>Call without registration</b> . Choosing <b>Auto</b> is recommended.

The system will select a proper way for your VoIP call.

Register via

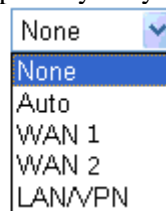

**SIP Port**

Set the port number for sending/receiving SIP message for building a session. The default value is **5060**. Your peer must set the same value in his/her Registrar.

**Domain/Realm**

Set the domain name or IP address of the SIP Registrar server.

**Proxy**

Set domain name or IP address of SIP proxy server. By the time you can type:**port number** after the domain name to specify that port as the destination of data transmission (e.g., **nat.draytel.org:5065**)

**Act as Outbound Proxy**

Check this box to make the proxy acting as outbound proxy.

**Display Name**

The caller-ID that you want to be displayed on your friend's screen.

**Account Number/Name**

Enter your account name of SIP Address, e.g. every text before @..

**Authentication ID**

Check the box to invoke this function and enter the name or number used for SIP Authorization with SIP Registrar. If this setting value is the same as Account Name, it is not necessary for you to check the box and set any value in this field.

**Password**

The password provided to you when you registered with a SIP service.

**Expiry Time**

The time duration that your SIP Registrar server keeps your registration record. Before the time expires, the router will send another register request to SIP Registrar again.

**NAT Traversal Support**

If the router (e.g., broadband router) you use connects to internet by other device, you have to set this function for your necessity.

NAT Traversal Support

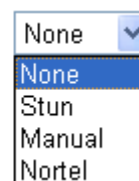

**None** – Disable this function.

**Stun** – Choose this option if there is Stun server provided for your router.

**Manual** – Choose this option if you want to specify an external IP address as the NAT transversal support.

**Nortel** – If the soft-switch that you use supports Nortel solution, you can choose this option.

**Ring Port**

Set Phone1, Phone2, ISDN1-S0 or ISDN-TE as the default ring port for this SIP account. If you choose Phone1, Phone2 or ISDN1-S0, the ISDN2-TE selection will be dimmed, vice versa. There are ten internal lines with numbers (30 – 39) offered for **ISDN-S0**. You can specify one of them or choose

Any as ring port for specified SIP account. By the way, ISDN-S0 can be used by mapping with MSN numbers.

### Ring Pattern

Choose a ring tone type for the VoIP phone call.

Ring Pattern

## 3.12.3 Phone Settings

This page allows user to set phone settings for Phone1, Phone2, ISDN1-S0 and ISDN2-TE/S0 respectively.

VoIP >> Phone Settings

### Phone List

Index	Port	Call Feature	Codec	Tone	Gain (Mic/Speaker)	Default SIP Account	DTMF Relay
1	Phone1		G.729A/B	User Defined	5/5		InBand
2	Phone2		G.729A/B	User Defined	5/5		InBand
3	ISDN1-S0		G.729A/B	User Defined	5/5		InBand
4	ISDN2-TE		G.729A/B	User Defined	5/5		InBand

### RTP

Symmetric RTP

Dynamic RTP Port Start

Dynamic RTP Port End

RTP TOS

OK

### Phone List

**Port** – There are four phone ports provided here for you to configure. Three (Index 1 to 3) are fixed and one (Index 4) is configurable. **Phone1** and **Phone2** allow you to set general settings for PSTN phones. **ISDN1-S0** and **ISDN2-TE** allow you to set common settings for ISDN network connection. ISDN2 port is configurable. Please use the drop down list to choose **ISDN2-TE** for Internet connection or choose **ISDN2-S0** (ISDN intern) for ISDN phone. In addition, you can connect six phones to this router in certain case. Please refer to **Section 4-1** for detailed information of ISDN phone/network connection.

If you want to enable function of ISDN On-Net/Off-Net, you have to choose ISDN2-TE.

**Call Feature** – A brief description for call feature will be shown in this field for your reference.

**Codec** – The default Codec setting for each port will be shown in this field for your reference. You can click the number below the Index field to change it for each phone port.

**Tone** - Display the tone settings that configured in the advanced settings page of Phone Index.

**Gain** - Display the volume gain settings for Mic/Speaker that configured in the advanced settings page of Phone Index.

**Default SIP Account** – “draytel\_1” is the default SIP account. You can click the number below the Index field to change SIP account for each phone port.

**DTMF Relay** – Display DTMF mode that configured in the advanced settings page of Phone Index.

## RTP

**Symmetric RTP** – Check this box to invoke the function. To make the data transmission going through on both ends of local router and remote router not misleading due to IP lost (for example, sending data from the public IP of remote router to the private IP of local router), you can check this box to solve this problem.

**Dynamic RTP Port Start** - Specifies the start port for RTP stream. The default value is 10050.

**Dynamic RTP Port End** - Specifies the end port for RTP stream. The default value is 15000.

**RTP TOS** – It decides the level of VoIP package. Use the drop down list to choose any one of them.

RTP TOS

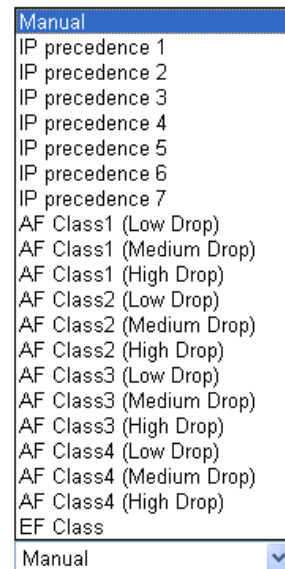

The image shows a screenshot of a web-based configuration interface. It features a dropdown menu for 'RTP TOS'. The menu is currently open, displaying a list of options. The top option is 'Manual', which is highlighted in blue. Below it, there are seven 'IP precedence' options (IP precedence 1 through IP precedence 7). Following these are several 'AF Class' options, including AF Class1 (Low Drop), AF Class1 (Medium Drop), AF Class1 (High Drop), AF Class2 (Low Drop), AF Class2 (Medium Drop), AF Class2 (High Drop), AF Class3 (Low Drop), AF Class3 (Medium Drop), AF Class3 (High Drop), AF Class4 (Low Drop), AF Class4 (Medium Drop), and AF Class4 (High Drop). The bottom option is 'EF Class'. At the bottom of the dropdown, the text 'Manual' is visible next to a small blue downward-pointing arrow, indicating the current selection.

## Detailed Settings for Phone1/Phone2 Port

Click the number link of each port, you can access into the following page for configuring Phone settings. Below is the sample page for Phone1.

**Phone1**

<p><b>Call Feature</b></p> <p><input type="checkbox"/> Hotline</p> <p><input type="checkbox"/> Session Timer <input type="text" value="3600"/> sec</p> <p><input type="checkbox"/> T.38 Fax Function</p> <p>Call Forwarding <input type="text" value="Disable"/> ▾</p> <p>SIP URL <input type="text"/></p> <p>Time Out <input type="text" value="30"/> sec</p> <p><input type="checkbox"/> DND(Do Not Disturb) Mode</p> <p>Index(1-15) in <b>Schedule</b> Setup: <input type="text"/> , <input type="text"/> , <input type="text"/> , <input type="text"/></p> <p><b>Note:</b> Action and Idle Timeout settings will be ignored.</p> <p>Index(1-60) in <b>Phone Book</b> as Exception List: <input type="text"/> , <input type="text"/> , <input type="text"/> , <input type="text"/> , <input type="text"/></p> <p><input type="checkbox"/> CLIR (hide caller ID)</p> <p><input type="checkbox"/> Call Waiting</p> <p><input type="checkbox"/> Call Transfer</p>	<p><b>Codecs</b></p> <p>Prefer Codec <input type="text" value="G.729A/B (8Kbps)"/> ▾</p> <p><input type="checkbox"/> Single Codec</p> <p>Packet Size <input type="text" value="20ms"/> ▾</p> <p>Voice Active Detector <input type="text" value="Off"/> ▾</p> <p><b>Default SIP Account</b> <input type="text"/> ▾</p> <p><input type="checkbox"/> Play dial tone only when account registered</p> <p><b>Default Call Route</b></p> <p><input type="radio"/> To ISDN: Dial <input type="text" value="*#"/> for VoIP</p> <p><input checked="" type="radio"/> To VoIP: Dial <input type="text" value="*#"/> for ISDN</p>
---	---

OK Cancel Advanced

**Hotline**

Check the box to enable it. Type in the SIP URL in the field for dialing automatically when you pick up the phone set.

**Session Timer**

Check the box to enable the function. In the limited time that you set in this field, if there is no response, the connecting call will be closed automatically.

**Call Forwarding**

There are four options for you to choose. **Disable** is to close call forwarding function. **Always** means all the incoming calls will be forwarded into SIP URL without any reason. **Busy** means the incoming calls will be forwarded into SIP URL only when the local system is busy. **No answer** means if the incoming calls do not receive any response, they will be forwarded to the SIP URL by the time out.

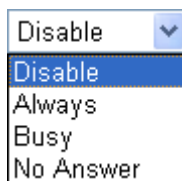

**SIP URL** – Type in the SIP URL (e.g., aaa@draytel.org or abc@iptel.org) as the site for call forwarded.

**Time Out** – Set the time out for the call forwarding. The default setting is 30 sec.

**DND (Do Not Disturb) mode**

Set a period of peace time without disturbing by VoIP phone call. During the period, the one who dial in will listen busy tone, yet the local user will not listen any ring tone.

**Index (1-15) in Schedule** - Enter the index of schedule profiles to control the DND mode according to the preconfigured schedules. Refer to section 3.5.2 Schedule for

detailed configuration.

**Index (1-60) in Phone Book** - Enter the index of phone book profiles. Refer to section **3.11.1 DialPlan – Phone Book** for detailed configuration.

**CLIR (hide caller ID)**

Check this box to hide the caller ID on the display panel of the phone set.

**Call Waiting**

Check this box to invoke this function. A notice sound will appear to tell the user new phone call is waiting for your response. Click hook flash to pick up the waiting phone call.

**Call Transfer**

Check this box to invoke this function. Click hook flash to initiate another phone call. When the phone call connection succeeds, hang up the phone. The other two sides can communicate, then.

**Prefer Codec**

Select one of five codecs as the default for your VoIP calls. The codec used for each call will be negotiated with the peer party before each session, and so may not be your default choice. The default codec is G.729A/B; it occupies little bandwidth while maintaining good voice quality.

If your upstream speed is only 64Kbps, do not use G.711 codec. It is better for you to have at least 256Kbps upstream if you would like to use G.711.

Prefer Codec

G.711A (64Kbps)	▼
G.711MU (64Kbps)	
G.711A (64Kbps)	
G.729A/B (8Kbps)	
G.723 (6.4kbps)	
G.726_32 (32kbps)	

**Single Codec** – If the box is checked, only the selected Codec will be applied.

**Packet Size**-The amount of data contained in a single packet. The default value is 20 ms, which means the data packet will contain 20 ms voice information.

Packet Size

20ms	▼
10ms	
20ms	
30ms	
40ms	
50ms	
60ms	

**Voice Active Detector** - This function can detect if the voice on both sides is active or not. If not, the router will do something to save the bandwidth for other using. Click On to invoke this function; click off to close the function.

Voice Active Detector

Off	▼
Off	
On	

**Default SIP Account**

You can set SIP accounts (up to six groups) on SIP Account page. Use the drop down list to choose one of the profile names for the accounts as the default one for this phone setting.

**Play dial tone only when account registered** - Check this box to invoke the function.

**Default Call Route**

It determines the default direction for the call route of the router.

**To ISDN (for VoIP)** - The router is set by using ISDN call. To change ISDN call into VoIP call, please dial the character in this field for transferring. The character that you can type can be \*, #, and 0~9.

**To VoIP (for ISDN)** - The router is set by using VoIP call. To change VoIP call into ISDN call, please dial the character in this field for transferring. The character that you can type can be \*, #, and 0~9.

In addition, you can press the **Advanced** button to configure tone settings, volume gain, MISC and DTMF mode. **Advanced** setting is provided for fitting the telecommunication custom for the local area of the router installed. Wrong tone settings might cause inconvenience for users. To set the sound pattern of the phone set, simply choose a proper region to let the system find out the preset tone settings and caller ID type automatically. Or you can adjust tone settings manually if you choose User Defined. TOn1, TOff1, TOn2 and TOff2 mean the cadence of the tone pattern. TOn1 and TOn2 represent sound-on; TOff1 and TOff2 represent the sound-off.

**VoIP >> Phone Settings**

**Advance Settings >> Phone1**

**Tone Settings**

Region

	Low Freq (Hz)	High Freq (Hz)	T on 1 (msec)	T off 1 (msec)	T on 2 (msec)	T off 2 (msec)
<b>Dial tone</b>	<input type="text" value="350"/>	<input type="text" value="440"/>	<input type="text" value="0"/>	<input type="text" value="0"/>	<input type="text" value="0"/>	<input type="text" value="0"/>
<b>Ringing tone</b>	<input type="text" value="400"/>	<input type="text" value="450"/>	<input type="text" value="400"/>	<input type="text" value="200"/>	<input type="text" value="400"/>	<input type="text" value="2000"/>
<b>Busy tone</b>	<input type="text" value="400"/>	<input type="text" value="0"/>	<input type="text" value="375"/>	<input type="text" value="375"/>	<input type="text" value="0"/>	<input type="text" value="0"/>
<b>Congestion tone</b>	<input type="text" value="0"/>	<input type="text" value="0"/>	<input type="text" value="0"/>	<input type="text" value="0"/>	<input type="text" value="0"/>	<input type="text" value="0"/>

**Volume Gain**

Mic Gain(1-10)

Speaker Gain(1-10)

**DTMF**

DTMF Mode

Payload Type(RFC2833)

**MISC**

Dial Tone Power Level

Ring Frequency

**Region**

Select the proper region which you are located. The common settings of **Caller ID Type**, **Dial tone**, **Ringing tone**, **Busy tone** and **Congestion tone** will be shown automatically on the page. If you cannot find out a suitable one, please choose **User Defined** and fill out the corresponding values for dial tone, ringing tone, busy tone, congestion tone by yourself for VoIP phone.

## Advance Settings >> Phone

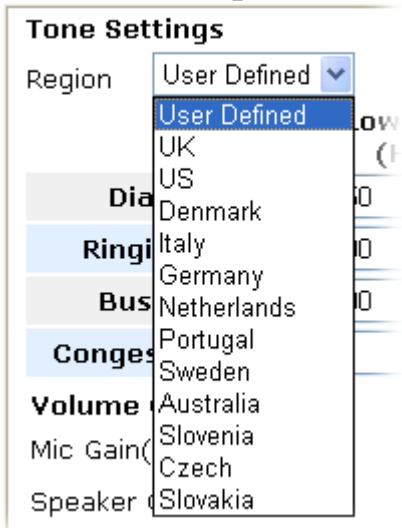

Also, you can specify each field for your necessity. It is recommended for you to use the default settings for VoIP communication.

### Volume Gain

**Mic Gain (1-10)/Speaker Gain (1-10)** - Adjust the volume of microphone and speaker by entering number from 1- 10. The larger of the number, the louder the volume is.

### MISC

**Dial Tone Power Level** - This setting is used to adjust the loudness of the dial tone. The smaller the number is, the louder the dial tone is. It is recommended for you to use the default setting.

**Ring Frequency** - This setting is used to drive the frequency of the ring tone. It is recommended for you to use the default setting.

### DTMF

**DTMF Mode** – There are four DTMF modes for you to choose.

**InBand** - Choose this one then the Vigor will send the DTMF tone as audio directly when you press the keypad on the phone

**OutBand** - Choose this one then the Vigor will capture the keypad number you pressed and transform it to digital form then send to the other side; the receiver will generate the tone according to the digital form it receive. This function is very useful when the network traffic congestion occurs and it still can remain the accuracy of DTMF tone.

**SIP INFO**- Choose this one then the Vigor will capture the DTMF tone and transfer it into SIP form. Then it will be sent to the remote end with SIP message.

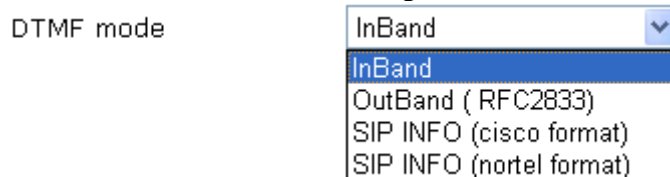

**Payload Type (rfc2833)** - Choose a number from 96 to 127, the default value was 101. This setting is available for the OutBand (RFC2833) mode.



## Detailed Settings for ISDN1-S0 Port

Click the number link of Index 3 (ISDN1-S0), you can access into the following page for configuring Phone settings.

VoIP >> Phone Settings

**ISDN1-S0**

<p><b>Call Feature</b></p> <p><input type="checkbox"/> Hotline <input type="text"/></p> <p><input type="checkbox"/> Session Timer <input type="text" value="3600"/> sec</p> <p>Call Forwarding <input type="text" value="Disable"/> ▼</p> <p>SIP URL <input type="text"/></p> <p>Time Out <input type="text" value="30"/> sec</p> <p><input type="checkbox"/> DND(Do Not Disturb) Mode Index(1-15) in <b>Schedule</b> Setup: <input type="text"/>, <input type="text"/>, <input type="text"/>, <input type="text"/></p> <p><b>Note:</b> Action and Idle Timeout settings will be ignored.</p> <p>Index(1-60) in <b>Phone Book</b> as Exception List: <input type="text"/>, <input type="text"/>, <input type="text"/>, <input type="text"/>, <input type="text"/></p> <p><input type="checkbox"/> CLIR (hide caller ID)</p> <p><input type="checkbox"/> Call Waiting</p> <p><input type="checkbox"/> Call Transfer</p>		<p><b>Codecs</b></p> <p>Prefer Codec <input type="text" value="G.729A/B (8Kbps)"/> ▼</p> <p><input type="checkbox"/> Single Codec</p> <p>Packet Size <input type="text" value="20ms"/> ▼</p> <p>Voice Active Detector <input type="text" value="Off"/> ▼</p> <p><b>Default SIP Account</b> <input type="text"/> ▼</p> <p>SIP Account for MSN30 <input type="text"/> ▼</p> <p>SIP Account for MSN31 <input type="text"/> ▼</p> <p>SIP Account for MSN32 <input type="text"/> ▼</p> <p>SIP Account for MSN33 <input type="text"/> ▼</p> <p>SIP Account for MSN34 <input type="text"/> ▼</p> <p>SIP Account for MSN35 <input type="text"/> ▼</p> <p>SIP Account for MSN36 <input type="text"/> ▼</p> <p>SIP Account for MSN37 <input type="text"/> ▼</p> <p>SIP Account for MSN38 <input type="text"/> ▼</p> <p>SIP Account for MSN39 <input type="text"/> ▼</p> <p><input type="checkbox"/> Play dial tone only when account registered</p> <p><b>Default Call Route</b></p> <p><input type="radio"/> To ISDN: Dial <input type="text" value="*#"/> for VoIP</p> <p><input checked="" type="radio"/> To VoIP: Dial <input type="text" value="#"/> for ISDN</p>	
--	--	--	--

OK Cancel Advanced

### Hotline

Check the box to enable it. Type in the SIP URL in the field for dialing automatically when you pick up the phone set.

### Session Timer

Check the box to enable the function. In the limited time that you set in this field, if there is no response, the connecting call will be closed automatically.

### Call Forwarding

There are four options for you to choose. **Disable** is to close call forwarding function. **Always** means all the incoming calls will be forwarded into SIP URL without any reason. **Busy** means the incoming calls will be forwarded into SIP URL only when the local system is busy. **No answer** means if the incoming calls do not receive any response, they will be forwarded to the SIP URL by the time out.

Disable ▼

Disable

Always

Busy

No Answer

**SIP URL** – Type in the SIP URL (e.g., aaa@draytel.org or abc@iptel.org) as the site for call forwarded.

**Time Out** – Set the time out for the call forwarding. The default setting is 30 sec.

**DND (Do Not Disturb) mode**

Set a period of peace time without disturbing by VoIP phone call. During the period, the one who dial in will listen busy tone, yet the local user will not listen any ring tone.

**Index (1-15) in Schedule** - Enter the index of schedule profiles to control the DND mode according to the preconfigured schedules. Refer to section **3.5.2 Schedule** for detailed configuration.

**Index (1-60) in Phone Book** - Enter the index of phone book profiles. Refer to section **3.10.1 DialPlan – Phone Book** for detailed configuration.

**CLIR (hide caller ID)**

Check this box to hide the caller ID on the display panel of the phone set.

**Call Waiting**

Check this box to invoke this function. A notice sound will appear to tell the user new phone call is waiting for your response. Click hook flash to pick up the waiting phone call.

**Call Transfer**

Check this box to invoke this function. Click hook flash to initiate another phone call. When the phone call connection succeeds, hang up the phone. The other two sides can communicate, then.

**Prefer Codec**

Select one of five codecs as the default for your VoIP calls. The codec used for each call will be negotiated with the peer party before each session, and so may not be your default choice. The default codec is G.729A/B; it occupies little bandwidth while maintaining good voice quality. If your upstream speed is only 64Kbps, do not use G.711 codec. It is better for you to have at least 256Kbps upstream if you would like to use G.711.

Prefer Codec

G.711A (64Kbps)	▼
G.711MU (64Kbps)	
G.711A (64Kbps)	
G.729A/B (8Kbps)	
G.723 (6.4kbps)	
G.726_32 (32kbps)	

**Single Codec** – If the box is checked, only the selected Codec will be applied.

**Packet Size**-The amount of data contained in a single packet. The default value is 20 ms, which means the data packet will contain 20 ms voice information.

Packet Size

20ms	▼
10ms	
20ms	
30ms	
40ms	
50ms	
60ms	

**Voice Active Detector** - This function can detect if the voice on both sides is active or not. If not, the router will do

something to save the bandwidth for other using. Click On to invoke this function; click off to close the function.

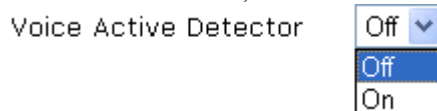

### Default SIP Account

You can set SIP accounts (up to six groups) on SIP Account page. Use the drop down list to choose one of the profile names for the accounts as the default one for this phone setting.

ISDN-S0 port can pick up multiple incoming calls simultaneously. Therefore different phone sets (MSN30 to MSN39) can use different SIP accounts to call out through this port.

**Play dial tone only when account registered** - Check this box to invoke the function.

### Default Call Route

It determines the default direction for the call route of the router.

**To ISDN (for VoIP)** - The router is set by using ISDN call. To change ISDN call into VoIP call, please dial the character in this field for transferring. The character that you can type can be \*, #, and 0~9.

**To VoIP (for ISDN)** - The router is set by using VoIP call. To change VoIP call into ISDN call, please dial the character in this field for transferring. The character that you can type can be \*, #, and 0~9.

In addition, you can press the **Advanced** button to configure tone settings, volume gain, MISC, DTMF mode and MSN number. **Advanced** setting is provided for fitting the telecommunication custom for the local area of the router installed. Wrong tone settings might cause inconvenience for users. To set the sound pattern of the phone set, simply choose a proper region to let the system find out the preset tone settings and caller ID type automatically. Or you can adjust tone settings manually if you choose User Defined. TOn1, TOff1, TOn2 and TOff2 mean the cadence of the tone pattern. TOn1 and TOn2 represent sound-on; TOff1 and TOff2 represent the sound-off.

Advance Settings >> ISDN1-S0

**Tone Settings**

Region  ▼

	Low Freq (Hz)	High Freq (Hz)	T on 1 (msec)	T off 1 (msec)	T on 2 (msec)	T off 2 (msec)
<b>Dial tone</b>	<input type="text" value="350"/>	<input type="text" value="440"/>	<input type="text" value="0"/>	<input type="text" value="0"/>	<input type="text" value="0"/>	<input type="text" value="0"/>
<b>Ringing tone</b>	<input type="text" value="400"/>	<input type="text" value="450"/>	<input type="text" value="400"/>	<input type="text" value="200"/>	<input type="text" value="400"/>	<input type="text" value="2000"/>
<b>Busy tone</b>	<input type="text" value="400"/>	<input type="text" value="0"/>	<input type="text" value="375"/>	<input type="text" value="375"/>	<input type="text" value="0"/>	<input type="text" value="0"/>
<b>Congestion tone</b>	<input type="text" value="0"/>	<input type="text" value="0"/>	<input type="text" value="0"/>	<input type="text" value="0"/>	<input type="text" value="0"/>	<input type="text" value="0"/>

**Volume Gain**

Mic Gain(1-10)

Speaker Gain(1-10)

**DTMF**

DTMF Mode  ▼

Payload Type(RFC2833)

**MISC**

Dial Tone Power Level

Ring Frequency

**Region**

Select the proper region which you are located. The common settings of **Caller ID Type**, **Dial tone**, **Ringing tone**, **Busy tone** and **Congestion tone** will be shown automatically on the page. If you cannot find out a suitable one, please choose **User Defined** and fill out the corresponding values for dial tone, ringing tone, busy tone, congestion tone by yourself for VoIP phone.

**Tone Settings**

Region  ▼

- User Defined
- UK
- US
- Denmark
- Italy
- Germany
- Netherlands
- Portugal
- Sweden
- Australia
- Slovenia
- Czech
- Slovakia

Also, you can specify each field for your necessity. It is recommended for you to use the default settings for VoIP communication.

**Volume Gain**

**Mic Gain (1-10)/Speaker Gain (1-10)** - Adjust the volume of microphone and speaker by entering number from 1- 10. The larger of the number, the louder the volume is.

**MISC**

**Dial Tone Power Level** - This setting is used to adjust the loudness of the dial tone. The smaller the number is, the louder the dial tone is. It is recommended for you to use the

default setting.

**Ring Frequency** - This setting is used to drive the frequency of the ring tone. It is recommended for you to use the default setting.

## DTMF

**DTMF Mode** – There are four DTMF modes for you to choose.

**InBand** - Choose this one then the Vigor will send the DTMF tone as audio directly when you press the keypad on the phone

**OutBand** - Choose this one then the Vigor will capture the keypad number you pressed and transform it to digital form then send to the other side; the receiver will generate the tone according to the digital form it receive. This function is very useful when the network traffic congestion occurs and it still can remain the accuracy of DTMF tone.

**SIP INFO**- Choose this one then the Vigor will capture the DTMF tone and transfer it into SIP form. Then it will be sent to the remote end with SIP message.

DTMF mode

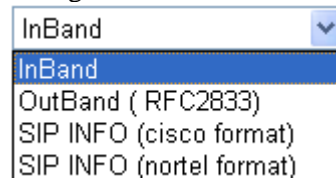

**Payload Type (rfc2833)** - Choose a number from 96 to 127, the default value was 101. This setting is available for the OutBand (RFC2833) mode.

## Detailed Settings for ISDN2-TE Port (Available for VS<sub>n</sub> model only)

Vigor2930VS<sub>n</sub> allows users to switch the function of ISDN2 port between TE or S0 mode. Please use the drop down list to choose the one you want.

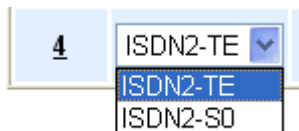

If you choose ISDN2-S0, please refer to Detailed Settings for Phone1, Phone2, ISDN1-S0 for the configuration. However, if you choose ISDN-TE and click the number link for that port, you will see the following page.

**ISDN2-TE**

<p><b>Call Feature</b></p> <p><input type="checkbox"/> Hotline <span style="float: right;">ISDN-&gt;VoIP ▼</span></p> <p><input type="checkbox"/> Session Timer <span style="float: right;">3600 sec</span></p> <p>Call Forwarding <span style="float: right;">Disable ▼</span></p> <p>SIP URL <span style="float: right;">[ ]</span></p> <p>Time Out <span style="float: right;">30 sec</span></p> <p><input type="checkbox"/> DND(Do Not Disturb) Mode</p> <p>Index(1-15) in <b>Schedule</b> Setup: [ ] , [ ] , [ ] , [ ]</p> <p><b>Note:</b> Action and Idle Timeout settings will be ignored.</p> <p>Index(1-60) in <b>Phone Book</b> as Exception List: [ ] , [ ] , [ ] , [ ] , [ ]</p> <p><input type="checkbox"/> CLIR (hide caller ID)</p>		<p><b>Codecs</b></p> <p>Prefer Codec <span style="float: right;">G.729A/B (8Kbps) ▼</span></p> <p><input type="checkbox"/> Single Codec</p> <p>Packet Size <span style="float: right;">20ms ▼</span></p> <p>Voice Active Detector <span style="float: right;">Off ▼</span></p> <p><b>Default SIP Account</b> <span style="float: right;">[ ] ▼</span></p> <p><input type="checkbox"/> Play dial tone only when account registered</p> <p><b>FXO feature</b></p> <p><input type="checkbox"/> Enable VoIP to ISDN (Off-Net) Calls</p> <p><input type="checkbox"/> Enable ISDN to VoIP (On-Net) Calls</p> <p><input checked="" type="radio"/> Loop Through to Phone Port</p> <p>Only when Router MSN mapping ring port is not set then this will take effect.</p> <p><input checked="" type="radio"/> Broadcast call <input type="radio"/> Phone1 <input type="radio"/> Phone2</p> <p><input type="radio"/> Loop Through to ISDN1-S0 Port</p>
--	--	--

**Hotline**

Check the box to enable it. Type in the SIP URL in the field for dialing automatically when you pick up the phone set.

**Session Timer**

Check the box to enable the function. In the limited time that you set in this field, if there is no response, the connecting call will be closed automatically.

**Call Forwarding**

There are four options for you to choose. **Disable** is to close call forwarding function. **Always** means all the incoming calls will be forwarded into SIP URL without any reason. **Busy** means the incoming calls will be forwarded into SIP URL only when the local system is busy. **No answer** means if the incoming calls do not receive any response, they will be forwarded to the SIP URL by the time out.

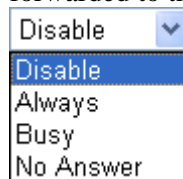

**SIP URL** – Type in the SIP URL (e.g., aaa@draytel.org or abc@iptel.org) as the site for call forwarded.

**Time Out** – Set the time out for the call forwarding. The default setting is 30 sec.

**DND (Do Not Disturb) mode**

Set a period of peace time without disturbing by VoIP phone call. During the period, the one who dial in will listen busy tone, yet the local user will not listen any ring tone.

**Index (1-15) in Schedule** - Enter the index of schedule profiles to control the DND mode according to the preconfigured schedules. Refer to section **3.5.2 Schedule** for detailed configuration.

**Index (1-60) in Phone Book** - Enter the index of phone book

profiles. Refer to section **3.10.1 DialPlan – Phone Book** for detailed configuration.

**CLIR (hide caller ID)**

Check this box to hide the caller ID on the display panel of the phone set.

**Prefer Codec**

Select one of five codecs as the default for your VoIP calls. The codec used for each call will be negotiated with the peer party before each session, and so may not be your default choice. The default codec is G.729A/B; it occupies little bandwidth while maintaining good voice quality. If your upstream speed is only 64Kbps, do not use G.711 codec. It is better for you to have at least 256Kbps upstream if you would like to use G.711.

Prefer Codec

G.711A (64Kbps)	▼
G.711MU (64Kbps)	
G.711A (64Kbps)	
G.729A/B (8Kbps)	
G.723 (6.4kbps)	
G.726_32 (32kbps)	

**Single Codec** – If the box is checked, only the selected Codec will be applied.

**Packet Size**-The amount of data contained in a single packet. The default value is 20 ms, which means the data packet will contain 20 ms voice information.

Packet Size

20ms	▼
10ms	
20ms	
30ms	
40ms	
50ms	
60ms	

**Voice Active Detector** - This function can detect if the voice on both sides is active or not. If not, the router will do something to save the bandwidth for other using. Click On to invoke this function; click off to close the function.

Voice Active Detector

Off	▼
Off	
On	

**Default SIP Account**

You can set SIP accounts (up to six groups) on SIP Account page. Use the drop down list to choose one of the profile names for the accounts as the default one for this phone setting.

**Play dial tone only when account registered** - Check this box to invoke the function.

**FXO Feature**

**Enable ISDN to VoIP (On-Net) Calls** – Check this box to make all the outgoing calls from ISDN line to be forwarded to receivers by Internet.

**Enable VoIP to ISDN (Off-Net) Calls** –Check this box to make all the incoming calls coming from Internet to be forwarded to receivers by ISDN line.

**Loop Through to Phone Port** – Choose this radio button to make all the calls controlled by traditional PSTN phone. It will tack effect only if MSN mapping ring port is not

configured. In addition, you can specify which port (both phone 1 and phone 2, phone 1 only or phone 2 only) will ring. **Loop Through to ISDN1-S0 Port** – Choose this radio button to make all the calls controlled by ISDN line.

In addition, you can press the **Advanced** button to configure tone settings, volume gain, MISC and DTMF mode. **Advanced** setting is provided for fitting the telecommunication custom for the local area of the router installed. Wrong tone settings might cause inconvenience for users. To set the sound pattern of the phone set, simply choose a proper region to let the system find out the preset tone settings and caller ID type automatically. Or you can adjust tone settings manually if you choose User Defined. TOn1, TOff1, TOn2 and TOff2 mean the cadence of the tone pattern. TOn1 and TOn2 represent sound-on; TOff1 and TOff2 represent the sound-off.

VoIP >> Phone Settings

Advance Settings >> ISDN2-TE

**Tone Settings**

Region User Defined

	Low Freq (Hz)	High Freq (Hz)	T on 1 (msec)	T off 1 (msec)	T on 2 (msec)	T off 2 (msec)
<b>Dial tone</b>	<input type="text" value="350"/>	<input type="text" value="440"/>	<input type="text" value="0"/>	<input type="text" value="0"/>	<input type="text" value="0"/>	<input type="text" value="0"/>
<b>Ringing tone</b>	<input type="text" value="400"/>	<input type="text" value="450"/>	<input type="text" value="400"/>	<input type="text" value="200"/>	<input type="text" value="400"/>	<input type="text" value="2000"/>
<b>Busy tone</b>	<input type="text" value="400"/>	<input type="text" value="0"/>	<input type="text" value="375"/>	<input type="text" value="375"/>	<input type="text" value="0"/>	<input type="text" value="0"/>
<b>Congestion tone</b>	<input type="text" value="0"/>	<input type="text" value="0"/>	<input type="text" value="0"/>	<input type="text" value="0"/>	<input type="text" value="0"/>	<input type="text" value="0"/>

**Volume Gain**

Mic Gain(1-10)

Speaker Gain(1-10)

**MISC**

Dial Tone Power Level

**DTMF**

DTMF Mode InBand

Payload Type(RFC2833)

**Authentication PIN Code**

Check for ISDN to VoIP Calls

Check for VoIP to ISDN Calls

**Disallow VoIP to ISDN Calls with the Following Prefixes**

OK
Cancel

**Region**

Select the proper region which you are located. The common settings of **Caller ID Type**, **Dial tone**, **Ringing tone**, **Busy tone** and **Congestion tone** will be shown automatically on the page. If you cannot find out a suitable one, please choose **User Defined** and fill out the corresponding values for dial tone, ringing tone, busy tone, congestion tone by yourself for VoIP phone.



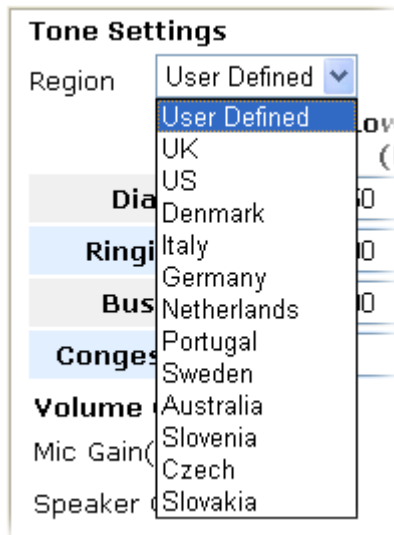

Also, you can specify each field for your necessity. It is recommended for you to use the default settings for VoIP communication.

**Volume Gain**

**Mic Gain (1-10)/Speaker Gain (1-10)** - Adjust the volume of microphone and speaker by entering number from 1- 10. The larger of the number, the louder the volume is.

**MISC**

**Dial Tone Power Level** - This setting is used to adjust the loudness of the dial tone. The smaller the number is, the louder the dial tone is. It is recommended for you to use the default setting.

**Authentication PIN Code**

**Check for ISDN to VoIP Calls** – Set a pin code for the router to authenticate which one is allowed to dial ISDN to VoIP call. The figure that you can type in this field is limited from three to eight with digits from zero to nine.

**Check for VoIP to ISDN Calls** - Set a pin code for the router to authenticate which one is allowed to dial VoIP to ISDN call. The figure that you can type in this field is limited from three to eight with digits from zero to nine.

**DTMP**

**DTMF mode** – There are four selections provided here:

**InBand:** Choose this one then the Vigor will send the DTMF tone as audio directly when you press the keypad on the phone

**OutBand:** Choose this one then the Vigor will capture the keypad number you pressed and transform it to digital form then send to the other side; the receiver will generate the tone according to the digital form it receive. This function is very useful when the network traffic congestion occurs and it still can remain the accuracy of DTMF tone.

**SIP INFO:** Choose this one then the Vigor will capture the DTMF tone and transfer it into SIP form. Then it will be sent to the remote end with SIP message.

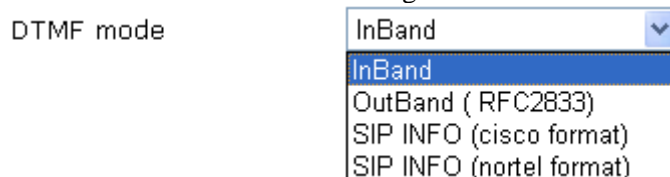

**Payload Type (rfc2833)** - Choose a number from 96 to 127,

the default value was 101. This setting is available for the OutBand (RFC2833) mode.

### 3.12.4 Status

From this page, you can find codec, connection and other important call status for each port.

VoIP >> Status

**Status** Refresh Seconds:

Port	Status	Codec	PeerID	Elapse (hh:mm:ss)	Tx Pkts	Rx Pkts	Rx Losts	Rx Jitter (ms)	In Calls	Out Calls	Miss Calls	Speaker Gain
Phone1	IDLE			00:00:00	0	0	0	0	0	0	0	5
Phone2	IDLE			00:00:00	0	0	0	0	0	0	0	5
ISDN1-B1	IDLE			00:00:00	0	0	0	0	0	0	0	5
ISDN1-B2	IDLE			00:00:00	0	0	0	0	0	0	0	5
ISDN2-B1	IDLE			00:00:00	0	0	0	0	0	0	0	5
ISDN2-B2	IDLE			00:00:00	0	0	0	0	0	0	0	5

  

**Log**

Date (mm-dd-yyyy)	Time (hh:mm:ss)	Duration (hh:mm:ss)	In/Out/Miss	Account ID	Peer ID
00-00-0	00:00:00	00:00:00	-	-	-
00-00-0	00:00:00	00:00:00	-	-	-
00-00-0	00:00:00	00:00:00	-	-	-
00-00-0	00:00:00	00:00:00	-	-	-
00-00-0	00:00:00	00:00:00	-	-	-
00-00-0	00:00:00	00:00:00	-	-	-
00-00-0	00:00:00	00:00:00	-	-	-
00-00-0	00:00:00	00:00:00	-	-	-
00-00-0	00:00:00	00:00:00	-	-	-
00-00-0	00:00:00	00:00:00	-	-	-

**Refresh Seconds**

Specify the interval of refresh time to obtain the latest VoIP calling information. The information will update immediately when the Refresh button is clicked.

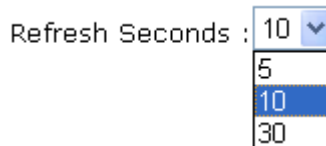

**Port**

It shows current connection status for the port of Phone1, Phone2, ISDN1 and ISDN2. The ISDN1/2 appears only when the router is equipped with ISDN interface. ISDN1 means B1 channel for the physical ISDN port; ISDN2 means B2 channel for the physical ISDN port. Be aware that ISDN1/2 port is available for the users living in Europe and using VigorPro5300 VSn only. For other V models, only the status for VoIP1 and VoIP2 will be shown in this page.

**Status**

It shows the VoIP connection status.  
**IDLE** - Indicates that the VoIP function is idle.  
**HANG\_UP** - Indicates that the connection is not established (busy tone).  
**CONNECTING** - Indicates that the user is calling out.  
**WAIT\_ANS** - Indicates that a connection is launched and waiting for remote user's answer.

	<b>ALERTING</b> - Indicates that a call is coming.
	<b>ACTIVE</b> -Indicates that the VoIP connection is launched.
<b>Codec</b>	Indicates the voice codec employed by present channel.
<b>PeerID</b>	The present in-call or out-call peer ID (the format may be IP or Domain).
<b>EIapse</b>	The format is represented as hours:minutes:seconds.
<b>Tx Pkts</b>	Total number of transmitted voice packets during this connection session.
<b>Rx Pkts</b>	Total number of received voice packets during this connection session.
<b>Rx Losts</b>	Total number of lost packets during this connection session.
<b>Rx Jitter</b>	The jitter of received voice packets.
<b>In Calls</b>	The accumulating in-call times.
<b>Out Calls</b>	The accumulating out-call times.
<b>Speaker Gain</b>	The volume of present call.
<b>Log</b>	Display logs of VoIP calls.

## 3.13 ISDN

### 3.13.1 Basic Concept

ISDN means integrated services digital network that is an international communications standard for sending voice, video, and data over digital telephone lines or normal telephone wires.

Below shows the menu items for ISDN.

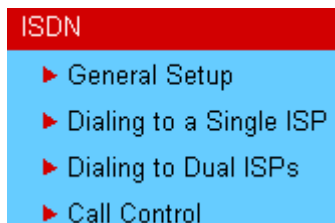

### 3.13.2 General Settings

This web page allows you to enable ISDN function.

ISDN >> General Setup

**ISDN Setup**

<p>ISDN Port <input checked="" type="radio"/> Enable <input type="radio"/> Disable</p> <p>Country Code <span style="border: 1px solid black; padding: 2px;">International</span></p> <p>D-Channel Mode</p> <p>ISDN1 <input type="radio"/> Point-to-Point <input checked="" type="radio"/> Point-to-Multipoint</p> <p>ISDN2 <input type="radio"/> Point-to-Point <input checked="" type="radio"/> Point-to-Multipoint</p> <p>Own Number <span style="border: 1px solid black; display: inline-block; width: 100px; height: 15px;"></span></p> <p><small>"Own Number" means that the router will tell the remote end the ISDN number when it's placing an outgoing call.</small></p> <p><small>Goto <a href="#">Phone Settings</a> to change ISDN TE-&gt;NT type.</small></p>	<p>Blocked MSN numbers for the router</p> <p>1. <span style="border: 1px solid black; display: inline-block; width: 100px; height: 15px;"></span></p> <p>2. <span style="border: 1px solid black; display: inline-block; width: 100px; height: 15px;"></span></p> <p>3. <span style="border: 1px solid black; display: inline-block; width: 100px; height: 15px;"></span></p> <p>4. <span style="border: 1px solid black; display: inline-block; width: 100px; height: 15px;"></span></p> <p>5. <span style="border: 1px solid black; display: inline-block; width: 100px; height: 15px;"></span></p>
---	---

Index	MSN numbers for the router	Mapping to Phone Ports	Phone CLIR/CLIP
1.	<span style="border: 1px solid black; display: inline-block; width: 100px; height: 15px;"></span>	<input type="checkbox"/> Phone1 <input type="checkbox"/> Phone2 <input type="checkbox"/> ISDN1-S0 <span style="border: 1px solid black; padding: 2px;">Any</span>	<input type="checkbox"/> <input type="checkbox"/>
2.	<span style="border: 1px solid black; display: inline-block; width: 100px; height: 15px;"></span>	<input type="checkbox"/> Phone1 <input type="checkbox"/> Phone2 <input type="checkbox"/> ISDN1-S0 <span style="border: 1px solid black; padding: 2px;">Any</span>	<input type="checkbox"/> <input type="checkbox"/>
3.	<span style="border: 1px solid black; display: inline-block; width: 100px; height: 15px;"></span>	<input type="checkbox"/> Phone1 <input type="checkbox"/> Phone2 <input type="checkbox"/> ISDN1-S0 <span style="border: 1px solid black; padding: 2px;">Any</span>	<input type="checkbox"/> <input type="checkbox"/>
4.	<span style="border: 1px solid black; display: inline-block; width: 100px; height: 15px;"></span>	<input type="checkbox"/> Phone1 <input type="checkbox"/> Phone2 <input type="checkbox"/> ISDN1-S0 <span style="border: 1px solid black; padding: 2px;">Any</span>	<input type="checkbox"/> <input type="checkbox"/>
5.	<span style="border: 1px solid black; display: inline-block; width: 100px; height: 15px;"></span>	<input type="checkbox"/> Phone1 <input type="checkbox"/> Phone2 <input type="checkbox"/> ISDN1-S0 <span style="border: 1px solid black; padding: 2px;">Any</span>	<input type="checkbox"/> <input type="checkbox"/>
6.	<span style="border: 1px solid black; display: inline-block; width: 100px; height: 15px;"></span>	<input type="checkbox"/> Phone1 <input type="checkbox"/> Phone2 <input type="checkbox"/> ISDN1-S0 <span style="border: 1px solid black; padding: 2px;">Any</span>	<input type="checkbox"/> <input type="checkbox"/>
7.	<span style="border: 1px solid black; display: inline-block; width: 100px; height: 15px;"></span>	<input type="checkbox"/> Phone1 <input type="checkbox"/> Phone2 <input type="checkbox"/> ISDN1-S0 <span style="border: 1px solid black; padding: 2px;">Any</span>	<input type="checkbox"/> <input type="checkbox"/>
8.	<span style="border: 1px solid black; display: inline-block; width: 100px; height: 15px;"></span>	<input type="checkbox"/> Phone1 <input type="checkbox"/> Phone2 <input type="checkbox"/> ISDN1-S0 <span style="border: 1px solid black; padding: 2px;">Any</span>	<input type="checkbox"/> <input type="checkbox"/>
9.	<span style="border: 1px solid black; display: inline-block; width: 100px; height: 15px;"></span>	<input type="checkbox"/> Phone1 <input type="checkbox"/> Phone2 <input type="checkbox"/> ISDN1-S0 <span style="border: 1px solid black; padding: 2px;">Any</span>	<input type="checkbox"/> <input type="checkbox"/>
10.	<span style="border: 1px solid black; display: inline-block; width: 100px; height: 15px;"></span>	<input type="checkbox"/> Phone1 <input type="checkbox"/> Phone2 <input type="checkbox"/> ISDN1-S0 <span style="border: 1px solid black; padding: 2px;">Any</span>	<input type="checkbox"/> <input type="checkbox"/>

"MSN Numbers" means that the router is able to accept number-matched incoming calls. In addition, MSN service should be supported by the local ISDN network provider.

OK
Cancel

**ISDN Port**

Click **Enable** to open the ISDN port and **Disable** to close it.

**Country Code**

For proper operation on your local ISDN network, you should choose the correct country code.

**D-Channel Mode**

It allows you to configure ISDN layer2 protocol as:  
**Point-to-Point** - Configure ISDN port to use static TEI (Terminal Endpoint Identifier).  
**Point-to-Multipoint** - Configure ISDN port to use Dynamic TEI.

**Own Number**

Enter your ISDN number that you got from ISDN service provider (To have such number, you have offer your request from ISDN service provider first). Every outgoing call will carry the number to the receiver.

**Blocked MSN Numbers for the router**

Enter the specified MSN number into the fields to prevent the router from dialing the specific MSN number

## MSN Numbers for the Router

MSN Numbers mean that the router is able to accept only number-matched incoming calls. In addition, local ISDN network provider should support MSN services. The router provides three fields for MSN numbers. Note that MSN services must be acquired from your local telecom operators. By default, MSN function is disabled. If you leave the fields blank, all incoming calls will be accepted without number matching.

**1-10 fields** – Fill in the portion that is different with the own number.

For example, the own number is **1234567** and MSN numbers are **1234550**, **1234517** and **1234582** respectively. You can type in **1234567** in the field of own number. Fill in **50**, **17** and **67** on the fields of 1, 2 and 3 one by one without typing 12345.

## Mapping to Phone Ports

For loop through phone calls, you can assign Phone 1, Phone 2, ISDN1-S0 as ring ports if incoming calls correspond with settings on MSN number field.

There are ten internal lines (30-39) under ISDN1-S0 for you to configure as dedicated line. You can setup your ISDN phone with one of these 10 different internal MSN numbers. **Transparent** means MSN on TE port can connect to NT port without limitation on the number among 30 ~ 39. **Any** means all the phones under ISDN1-S0 would ring.

ISDN1-S0

Any
Any
Transparent
30
31
32
33
34
35
36
37
38
39

If you choose **Any** as ISDN-S0 port, when the router receives the incoming phone call with certain number for reaching ISDN-S0, all the phone sets connected to ISDN-S0 will ring at the same time.

## Phone CLIR/CLIP

CLIR means “Calling Line Identification Restriction”. If you choose this item, we will not let remote side see your phone number. Such function depends on environment that ISP offers to you. Usually, hidden telephone number is not permitted under many real circumstances.

CLIP means “Calling Line Identification Presentation”. Usually the router will send "Own Number" to the remote side. However **Own number** will restrict the router displaying only one number on remote side. Vigor2930 series can connect up to 6 phones at the same time. Therefore, if **CLIP** is selected,

the external MSN numbers that you setup will be displayed to remote side.

## Application Example

You got ISDN numbers with **5972720~5972729** from your ISP, and you try to connect ISDN-TE port to ISDN network. Please refer to the following configuration.

Open **ISDN>> General Setup** and set as the following:

ISDN >> General Setup

**ISDN Setup**

ISDN Port  Enable  Disable

Country Code

D-Channel Mode

ISDN1  Point-to-Point  Point-to-Multipoint

ISDN2  Point-to-Point  Point-to-Multipoint

Own Number

"Own Number" means that the router will tell the remote end the ISDN number when it's placing an outgoing call.

Goto [Phone Settings](#) to change ISDN TE->NT type.

Blocked MSN numbers for the router

1.

2.

3.

4.

5.

Index	MSN numbers for the router	Mapping to Phone Ports		ISDN1-S0	Phone CLIR/CLIP	
1.	<input type="text" value="5972727"/>	<input checked="" type="checkbox"/> Phone1	<input type="checkbox"/> Phone2	<input type="checkbox"/> ISDN1-S0	Any <input type="text"/>	<input type="checkbox"/> <input type="checkbox"/>
2.	<input type="text" value="5972728"/>	<input type="checkbox"/> Phone1	<input type="checkbox"/> Phone2	<input checked="" type="checkbox"/> ISDN1-S0	32 <input type="text"/>	<input checked="" type="checkbox"/> <input type="checkbox"/>
3.	<input type="text" value="5972729"/>	<input type="checkbox"/> Phone1	<input type="checkbox"/> Phone2	<input checked="" type="checkbox"/> ISDN1-S0	Transparent <input type="text"/>	<input type="checkbox"/> <input checked="" type="checkbox"/>
4.	<input type="text" value="5972720"/>	<input type="checkbox"/> Phone1	<input type="checkbox"/> Phone2	<input checked="" type="checkbox"/> ISDN1-S0	Any <input type="text"/>	<input type="checkbox"/> <input checked="" type="checkbox"/>

When remote user calls you by dialing **5972727**, the router will make Phone1 port ringing.

When remote user calls you by dialing **5972728**, the router will make ISDN phone under ISDN1-S0 port and configured with internal MSN number 32 ringing.

When remote user calls you by dialing **5972729**, the router will make ISDN phones under ISDN1-S0 port and configured with internal MSN number **5972729** ringing.

When remote user calls you by dialing **5972720**, the router will make all of ISDN phones under ISDN1-S0 port ringing.

When remote user calls you by dialing **5972722**, the router will make no phone ringing for the number is not specified in such page.

If you use Phone1 to dial an outgoing call: remote user will see the telephone number - 5972726 because CLIP is not checked.

If you use ISDN1-S0 with **MSN 32** to dial an outgoing call: remote user will see "Withheld Number" from the telephone display panel because Phone CLIR is checked.

If you use **ISDN1-S0 with MSN 5972729** to dial an outgoing call: remote user will see the number 5972729 because Phone CLIP is checked.

If you use **ISDN1-S0 without MSN Setup** to dial an outgoing call: remote user will see the number 5972720 because Phone CLIP is checked.

### 3.13.3 Dial to a Single ISP/Dial to Dual ISPs

Select **Dialing to a Single ISP** if you access the Internet via a single ISP.

ISDN >> Dialing to a Single ISP

**Single ISP**

<b>ISP Access Setup</b>	<b>PPP/MP Setup</b>
ISP Name <input type="text"/>	Link Type <input type="text" value="Dialup BOD"/>
Dial Number <input type="text"/>	PPP Authentication <input type="text" value="PAP or CHAP"/>
Username <input type="text"/>	Idle Timeout <input type="text" value="180"/> second(s)
Password <input type="text"/>	<b>IP Address Assignment Method (IPCP)</b>
<input type="checkbox"/> Require ISP callback (CBCP)	Fixed IP <input type="radio"/> Yes <input checked="" type="radio"/> No (Dynamic IP)
Index(1-15) in <b>Schedule</b> Setup:	Fixed IP Address <input type="text"/>
=> <input type="text"/> , <input type="text"/> , <input type="text"/> , <input type="text"/>	

#### ISP Access Setup

**ISP Name** - Enter your ISP name such as Seednet, Hinet and so on.

**Dial Number** - Enter the ISDN access number provided by your ISP.

**Username** - Enter the username provided by your ISP.

**Password** - Enter the password provided by your ISP.

**Require ISP Callback (CBCP)** - If your ISP supports the callback function, check this box to activate the Callback Control Protocol during the PPP negotiation.

**Scheduler (1-15)** - Enter the index of schedule profiles to control the Internet access according to the preconfigured schedules. Refer to section 3.7.2 **Schedule** for detailed configuration.

#### PPP/MP Setup

**Link Type** - There are three link types provided here for different purpose. **Link Disable** disables the ISDN dial-out function. **Dialup 64Kbps** allows you to use one ISDN B channel for Internet access. **Dialup 128Kbps** allows you to use both ISDN B channels for Internet access. **Dialup BOD** (for detailed information of configuration, please refer to section 3.10.5) stands for bandwidth-on-demand. The router will use only one B channel in low traffic situations. Once the single B channel bandwidth is fully used, the other B channel will be activated automatically through the dialup. For more detailed BOD parameter settings, please refer to the section of **Call Control**.

**PPP Authentication** - PAP only allows you to configure the PPP session to use the PAP protocol to negotiate the username and password with the ISP. **PAP or CHAP** is to configure the PPP session to use the PAP or CHAP protocols to negotiate the username and password with the ISP.

**Idle Timeout** - Idle timeout means the router will be disconnect after being idle for a preset amount of time. The default is 180 seconds. If you set the time to 0, the ISDN connection to the ISP will always remain on.

**IP Address Assignment Method (IPCP)**

In most environments, you should not change these settings as most ISPs provide a dynamic IP address for the router when it connects to the ISP. If your ISP provides a fixed IP address, check **Yes** and enter the IP address in the field of **Fixed IP Address**.

Select **Dialing to Dual ISPs** if you have more than one ISP. You will be able to dial to both ISPs at the same time. This is mainly for those ISPs that do not support Multiple-Link PPP (ML-PPP). In such cases, dialing to two ISPs can increase the bandwidth utilization of the ISDN channels to 128kbps data speed.

**ISDN >> Dialing to Dual ISPs**

Dual ISP	
<p><b>Common Settings</b></p> <p>1. <input type="checkbox"/> Enable Dual ISPs Function</p> <p>2. <input type="checkbox"/> Require ISP callback (CBCP)</p>	<p><b>PPP/MP Setup</b></p> <p>Link Type <input type="text" value="Dialup BOD"/></p> <p>PPP Authentication <input type="text" value="PAP or CHAP"/></p> <p>Idle Timeout <input type="text" value="180"/> second(s)</p>
<p><b>Primary ISP Setup</b></p> <p>ISP Name <input type="text"/></p> <p>Dial Number <input type="text"/></p> <p>Username <input type="text"/></p> <p>Password <input type="text"/></p> <p><b>IP Address Assignment Method (IPCP)</b></p> <p>Fixed IP <input type="radio"/> Yes <input checked="" type="radio"/> No (Dynamic IP)</p> <p>Fixed IP Address <input type="text"/></p>	<p><b>Secondary ISP Setup</b></p> <p>ISP Name <input type="text"/></p> <p>Dial Number <input type="text"/></p> <p>Username <input type="text" value="84005755@hinet.net"/></p> <p>Password <input type="text" value="••••••••"/></p> <p><b>IP Address Assignment Method (IPCP)</b></p> <p>Fixed IP <input type="radio"/> Yes <input checked="" type="radio"/> No (Dynamic IP)</p> <p>Fixed IP Address <input type="text"/></p>
<input type="button" value="OK"/>	

**Common Settings**

**Enable Dual ISPs Function** - Check to enable the Dual ISPs function. **Require ISP Callback (CBCP)** -If your ISP supports the callback function, check this box to activate the Callback Control Protocol during the PPP negotiation.

**PPP/MP Setup**

**Link Type** – There are three link types provided here for different purpose. **Link Disable** disables the ISDN dial-out function. **Dialup 128Kbps** allows you to use both ISDN B channels for Internet access. **Dialup BOD** (for detailed information of configuration, please refer to section 3.10.5) stands for bandwidth-on-demand. The router will use only one B channel in low traffic situations. Once the single B channel bandwidth is fully used, the other B channel will be activated automatically through the dialup.

**PPP Authentication** - PAP only allows you to configure the PPP session to use the PAP protocol to negotiate the username and password with the ISP. **PAP or CHAP** can configure the PPP session to use the PAP or CHAP protocols to negotiate the username and password with the ISP.

**Idle Timeout** - Idle timeout means the router will be disconnect after being idle for a preset amount of time. The



default is 180 seconds. If you set the time to 0, the ISDN connection to the ISP will always remain on.

### Primary ISP Setup

**ISP Name** - Enter your ISP name.

**Dial Number** -Enter the ISDN access number provided by your ISP.

**Username** - Enter the username provided by your ISP.

**Password** - Enter the password provided by your ISP.

### IP Address Assignment Method (IPCP) for primary ISP setup

In most environments, you should not change these settings as most ISPs provide a dynamic IP address for the router when it connects to the ISP. If your ISP provides a fixed IP address, check **Yes** and enter the IP address in the field of **Fixed IP Address**.

### Secondary ISP Setup)

**ISP Name** - Enter the secondary ISP name.

**Dial Number** -Enter the ISDN access number provided by the ISP.

**Username** - Enter the username provided by your ISP.

**Password** - Enter the password provided by your ISP.

### IP Address Assignment Method (IPCP) for secondary ISP setup

In most environments, you should not change these settings as most ISPs provide a dynamic IP address for the router when it connects to the ISP. If your ISP provides a fixed IP address, check **Yes** and enter the IP address in the field of **Fixed IP Address**.

After entering the necessary settings and clicking **OK**, you will see **Goto ISDN Diagnostic** link appears on the bottom of the webpage. To have an ISDN connection, please click this link.

ISDN >> Dialing to a Single ISP

#### Active Configuration

<b>ISP Access Setup</b> ISP Name <input type="text"/> Dial Number <input type="text" value="30"/> Username <input type="text" value="vivian"/> Password <input type="password" value="••••••"/> <input type="checkbox"/> Require ISP callback Index(1-15) in <b>Schedule</b> Setup: => <input type="text"/> , <input type="text"/> , <input type="text"/> , <input type="text"/> <b>&gt;&gt; Goto ISDN Diagnostic</b>	<b>PPP/MP Setup</b> Link Type <input type="text" value="Dialup BOD"/> PPP Authentication <input type="text" value="PAP or CHAP"/> Idle Timeout 180 second(s) <b>IP Address Assignment Method (IPCP)</b> Fixed IP <input type="radio"/> Yes <input checked="" type="radio"/> No (Dynamic IP) Fixed IP Address
---	--

Now, the system will guide you to click **Dial ISDN**. Wait for a moment after clicking the dial link. Then, a successful ISDN connection will be shown as the following.

## Online Status

System Status				System Uptime: 2:33:16			
<b>LAN Status</b>		Primary DNS: 194.109.6.66		Secondary DNS: 168.95.1.1			
IP Address		TX Packets	RX Packets				
192.168.1.1		12160	10217				
<b>WAN 1 Status</b>							
Enable	Line	Name	Mode	Up Time			
Yes	Ethernet		Static IP	2:33:06			
IP	GW IP	TX Packets	TX Rate(Bps)	RX Packets	RX Rate(Bps)		
172.16.3.229	172.16.3.4	8694	27	18977	499		
<b>WAN 2 Status</b>							
Enable	Line	Name	Mode	Up Time			
Yes	Ethernet		---	00:00:00			
IP	GW IP	TX Packets	TX Rate(Bps)	RX Packets	RX Rate(Bps)		
---	---	0	0	0	0		
<b>ISDN Status</b>							
				>> Dial ISDN	>> Drop B1	>> Drop B2	
Channel	Active Connection	TX Pkts	TX Rate (Bps)	RX Pkts	RX Rate (Bps)	Up Time	AOC
ISDN1-B1	[192.168.225.200]	19	4	18	4	0:0:46	0
ISDN1-B2	[192.168.225.200]	13	3	14	3	0:0:43	0

### 3.13.4 Call Control

Some applications require that the router (only for the ISDN models) be remotely activated, or be able to dial up to the ISP via the ISDN interface. Vigor routers provide this feature by allowing user to make a phone call to the router and then ask it to dial up to the ISP. Accordingly, a teleworker can access the remote network to retrieve resources. Of course, a fixed IP address is required for WAN connection and some internal network resource has to be exposed for remote users, such as FTP, WWW.

#### ISDN >> Call Control

Call Control Setup	
Dial Retry	<input type="text" value="0"/> times
Dial Delay Interval	<input type="text" value="0"/> second(s)
Remote Activation <input type="text"/>	
PPP/MP Dial-Out Setup	
<b>Basic Setup</b>	
Link Type	<input type="text" value="Dialup BOD"/>
PPP Authentication	<input type="text" value="PAP or CHAP"/>
TCP Header Compression	<input type="text" value="None"/>
Idle Timeout	<input type="text" value="180"/> second(s)
<b>Bandwidth On Demand (BOD) Setup</b>	
High Water Mark	<input type="text" value="7000"/> cps
High Water Time	<input type="text" value="30"/> second(s)
Low Water Mark	<input type="text" value="6000"/> cps
Low Water Time	<input type="text" value="30"/> second(s)
<input type="button" value="OK"/>	

#### Call Control Setup

**Dial Retry** - It specifies the dial retry counts per triggered packet. A triggered packet is the packet whose destination is outside the local network. The default setting is no dial retry. If set to 5, for each triggered packet, the router will dial 5 times until it is connected to the ISP or remote access router.

**Dial Delay Interval** - It specifies the interval between dialup retries. By default, the interval is 0 second.

**Remote Activation** - It can help users who would like to

access the server which is off the Internet in the head office. To remotely make the server to be available on the Internet, i.e. make the router in the head office activating its Internet access either by dialing-up or starting broadband connection, users can make a regular phone call (the number is set in the Remote Activation field) to the router as signaling it for activation. The phone call will be soon disconnected once the router is on line.

Note that **Dialing to a Single ISP** should be pre-configured properly.

### Basic Setup

**Link Type** - Because ISDN has two B channels (64Kbps/per channel), you can specify whether you would like to have single B channel, two B channels or BOD (Bandwidth on Demand). Four options are available: Link Disable, Dialup 64Kbps, Dialup 128Kbps, Dialup BOD.

Link Type

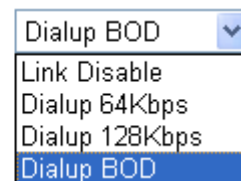

**PPP Authentication** - It specifies the PPP authentication method for PPP/MP connections. Normally you can set it to PAP/CHAP for better compatibility.

**TCP Header Compression - VJ Compression:** It is used for TCP/IP protocol header compression. Normally it is set to Yes to improve bandwidth utilization.

**Idle Timeout** - Because our ISDN link type is **Dial On Demand**, the connection will be initiated only when needed.

### Bandwidth-On-Demand (BOD) Setup

Bandwidth-On-Demand is for Multiple-Link PPP (ML-PPP or MP). The parameters are only applied when you set the **Link Type** to **Dialup BOD**. The ISDN usually use one B channel to access the Internet or remote network when you choose the Dialup BOD link type. The router will use the parameters here to decide on when you activate/drop the additional B channel. Note that **cps** (characters-per-second) measures the total link utilization.

**High Water Mark and High Water Time** - These parameters specify the situation in which the second channel will be activated. With the first connected channel, if its utilization exceeds the High Water Mark and such a channel is being used over the High Water Time, the additional channel will be activated. Thus, the total link speed will be 128kbps (two B channels).

**Low Water Mark and Low Water Time** - These parameters specify the situation in which the second channel will be dropped. In terms of the two B channels, if their utilization is under the Low Water Mark and these two channels are being used over the High Water Time, the additional channel will be dropped. As a result, the total link speed will be 64kbps (one B channel).

## 3.14 Wireless LAN

This function is used for G models only.

### 3.14.1 Basic Concepts

Over recent years, the market for wireless communications has enjoyed tremendous growth. Wireless technology now reaches or is capable of reaching virtually every location on the surface of the earth. Hundreds of millions of people exchange information every day via wireless communication products. The Vigor G model, a.k.a. Vigor wireless router, is designed for maximum flexibility and efficiency of a small office/home. Any authorized staff can bring a built-in WLAN client PDA or notebook into a meeting room for conference without laying a clot of LAN cable or drilling holes everywhere. Wireless LAN enables high mobility so WLAN users can simultaneously access all LAN facilities just like on a wired LAN as well as Internet access.

The Vigor wireless routers are equipped with a wireless LAN interface compliant with the standard IEEE 802.11g protocol. To boost its performance further, the Vigor Router is also loaded with advanced wireless technology Super G™ to lift up data rate up to 108 Mbps\*. Hence, you can finally smoothly enjoy stream music and video.

**Note:** \* The actual data throughput will vary according to the network conditions and environmental factors, including volume of network traffic, network overhead and building materials.

In an Infrastructure Mode of wireless network, Vigor wireless router plays a role as an Access Point (AP) connecting to lots of wireless clients or Stations (STA). All the STAs will share the same Internet connection via Vigor wireless router. The **General Settings** will set up the information of this wireless network, including its SSID as identification, located channel etc.

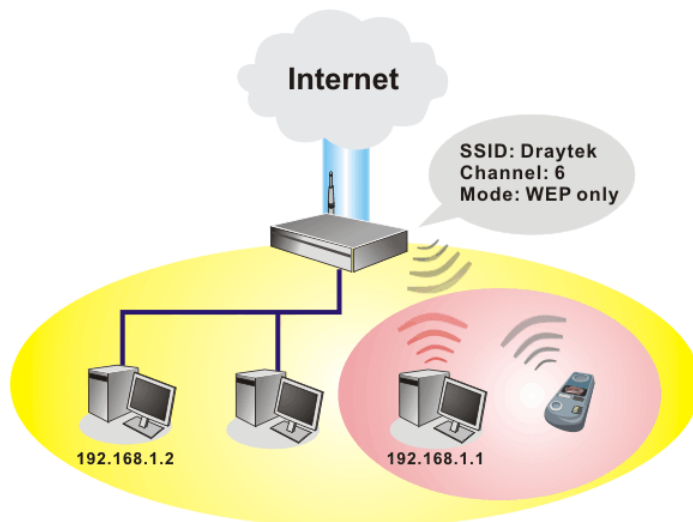

### Security Overview

**Real-time Hardware Encryption:** Vigor Router is equipped with a hardware AES encryption engine so it can apply the highest protection to your data without influencing user experience.

**Complete Security Standard Selection:** To ensure the security and privacy of your wireless communication, we provide several prevailing standards on market.

WEP (Wired Equivalent Privacy) is a legacy method to encrypt each frame transmitted via radio using either a 64-bit or 128-bit key. Usually access point will preset a set of four keys and it will communicate with each station using only one out of the four keys.

WPA(Wi-Fi Protected Access), the most dominating security mechanism in industry, is separated into two categories: WPA-personal or called WPA Pre-Share Key (WPA/PSK), and WPA-Enterprise or called WPA/802.1x.

In WPA-Personal, a pre-defined key is used for encryption during data transmission. WPA applies Temporal Key Integrity Protocol (TKIP) for data encryption while WPA2 applies AES. The WPA-Enterprise combines not only encryption but also authentication.

Since WEP has been proved vulnerable, you may consider using WPA for the most secure connection. You should select the appropriate security mechanism according to your needs. No matter which security suite you select, they all will enhance the over-the-air data protection and /or privacy on your wireless network. The Vigor wireless router is very flexible and can support multiple secure connections with both WEP and WPA at the same time.

**Example 1**

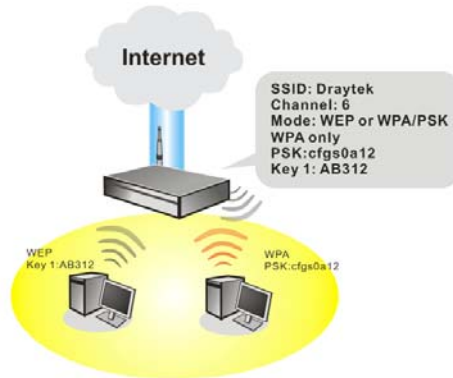

**Example 2**

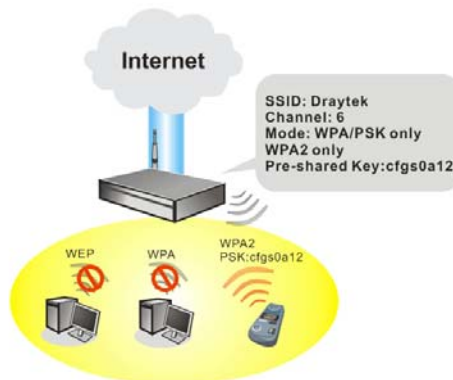

**Example 3**

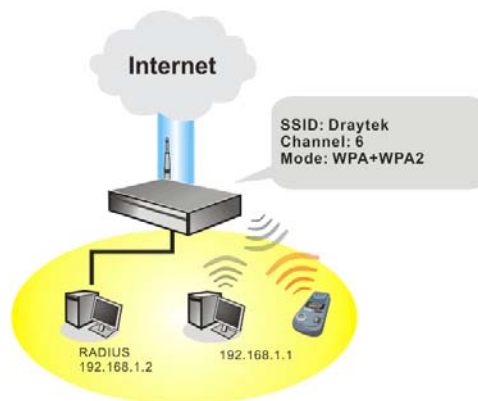

**Separate the Wireless and the Wired LAN- WLAN Isolation** enables you to isolate your wireless LAN from wired LAN for either quarantine or limit access reasons. To isolate means neither of the parties can access each other. To elaborate an example for business use, you may set up a wireless LAN for visitors only so they can connect to Internet without hassle of the confidential information leakage. For a more flexible deployment, you may add filters of MAC addresses to isolate users' access from wired LAN.

**Manage Wireless Stations - Station List** will display all the station in your wireless network and the status of their connection.

Below shows the menu items for Wireless LAN.



### 3.14.2 General Setup

By clicking the **General Settings**, a new web page will appear so that you could configure the SSID and the wireless channel. Please refer to the following figure for more information.

Wireless LAN >> General Setup

**General Setting ( IEEE 802.11 )**

Enable Wireless LAN

Mode : Mixed(11b+11g+11n)

---

Index(1-15) in **Schedule** Setup: , , ,

---

	Enable	Hide SSID	SSID	Isolate LAN	Member
1	<input checked="" type="checkbox"/>	<input type="checkbox"/>	default	<input type="checkbox"/>	<input type="checkbox"/>
2	<input type="checkbox"/>	<input type="checkbox"/>	<input style="width: 100%;" type="text"/>	<input type="checkbox"/>	<input type="checkbox"/>
3	<input type="checkbox"/>	<input type="checkbox"/>	<input style="width: 100%;" type="text"/>	<input type="checkbox"/>	<input type="checkbox"/>
4	<input type="checkbox"/>	<input type="checkbox"/>	<input style="width: 100%;" type="text"/>	<input type="checkbox"/>	<input type="checkbox"/>

**Hide SSID:** Prevent SSID from being scanned.  
**Isolate Member:** Wireless clients (stations) with the same SSID cannot access for each other.  
**Isolate LAN:** Wireless clients (stations) with the same SSID cannot access wired PCs on LAN.

---

Channel: Channel 6, 2437MHz Long Preamble:

Long Preamble: necessary for some old 802.11 b devices only(lower performance)

---

Packet-OVERDRIVE™

Tx Burst

**Note:**

- 1.Tx Burst only supports 11g mode.
- 2.The same technology must also be supported in clients to boost WLAN performance.

**Enable Wireless LAN**

Check the box to enable wireless function.

**Mode**

At present, the router can connect to Mixed (11b+11g), 11g Only, 11b Only, Mixed (11g+11n), 11n Only and Mixed (11b+11g+11n) stations simultaneously. Simply choose Mix (11b+11g+11n) mode.

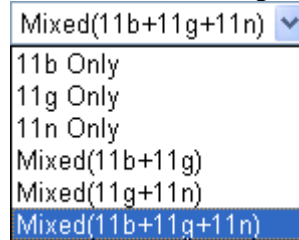

**Index(1-15)**

Set the wireless LAN to work at certain time interval only. You may choose up to 4 schedules out of the 15 schedules pre-defined in **Applications >> Schedule** setup. The default setting of this field is blank and the function will always work.

**Hide SSID**

Check it to prevent from wireless sniffing and make it harder for unauthorized clients or STAs to join your wireless LAN. Depending on the wireless utility, the user may only see the information except SSID or just cannot see anything about Vigor wireless router while site surveying. The system allows you to set four sets of SSID for different usage. In default, the first set of SSID will be enabled. You can hide it for your necessity.

**SSID**

The default SSID is "default". We suggest you change it to a particular name. It is the identification of the wireless LAN. SSID can be any text numbers or various special characters.

**Isolate**

**LAN** – Check this box to make the wireless clients (stations) with the same SSID cannot access wired PCs on LAN.

**Member** –Check this box to make the wireless clients (stations) with the same SSID not accessing for each other.

**Channel**

Means the channel of frequency of the wireless LAN. The default channel is 6. You may switch channel if the selected channel is under serious interference. If you have no idea of choosing the frequency, please select Auto to let system determine for you.

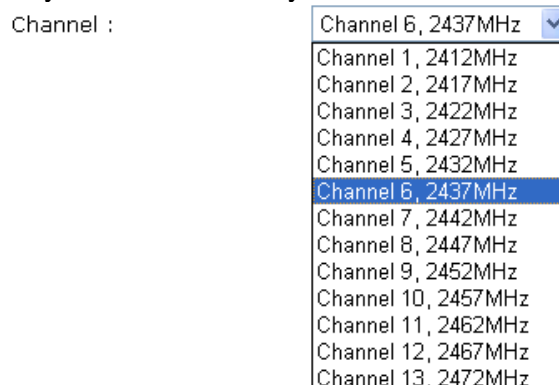

## Long Preamble

This option is to define the length of the sync field in an 802.11 packet. Most modern wireless network uses short preamble with 56 bit sync field instead of long preamble with 128 bit sync field. However, some original 11b wireless network devices only support long preamble. Check it to use **Long Preamble** if needed to communicate with this kind of devices.

## Packet-OVERDRIVE

This feature can enhance the performance in data transmission about 40%\* more (by checking **Tx Burst**). It is active only when both sides of Access Point and Station (in wireless client) invoke this function at the same time. That is, the wireless client must support this feature and invoke the function, too.

**Note:** Vigor N61 wireless adapter supports this function. Therefore, you can use and install it into your PC for matching with Packet-OVERDRIVE (refer to the following picture of Vigor N61 wireless utility window, choose **Enable** for activating TxBurst).

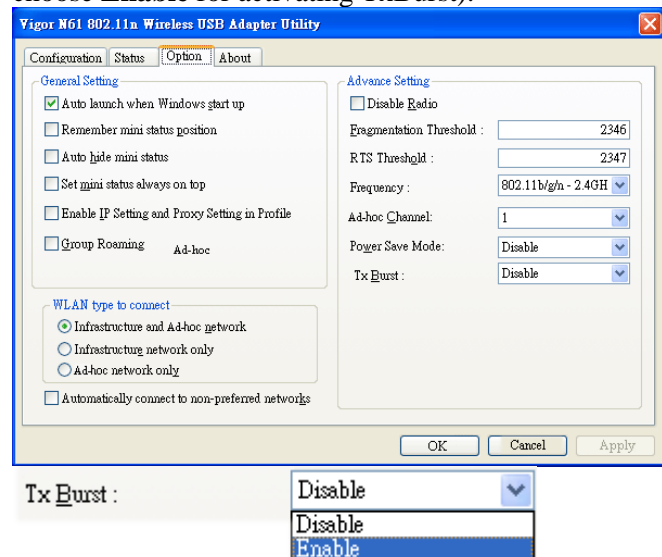

### 3.14.3 Security

This page allows you to set security with different modes for SSID 1, 2, 3 and 4 respectively. After configuring the correct settings, please click **OK** to save and invoke it.

By clicking the **Security Settings**, a new web page will appear so that you could configure the settings of WEP and WPA.



SSID 1	SSID 2	SSID 3	SSID 4
Mode: <span style="float: right;">Disable ▾</span>			
<b>WPA:</b>			
Pre-Shared Key(PSK): <input type="text" value="*****"/>			
Type 8~63 ASCII character or 64 Hexadecimal digits leading by "0x", for example "cfgs01a2..." or "0x655abcd....".			
<b>WEP:</b>			
Encryption Mode: <span style="float: right;">64-Bit ▾</span>			
<input checked="" type="radio"/> Key 1 : <input type="text" value="*****"/>			
<input type="radio"/> Key 2 : <input type="text" value="*****"/>			
<input type="radio"/> Key 3 : <input type="text" value="*****"/>			
<input type="radio"/> Key 4 : <input type="text" value="*****"/>			
<b>For 64 bit WEP key</b> Type 5 ASCII character or 10 Hexadecimal digits leading by "0x", for example "AB312" or "0x4142333132".			
<b>For 128 bit WEP key</b> Type 13 ASCII character or 26 Hexadecimal digits leading by "0x", for example "0123456789abc" or "0x30313233343536373839414243".			

**Mode**

There are several modes provided for you to choose.

▾

Disable

Disable

WEP

WPA/PSK

WPA2/PSK

Mixed(WPA+WPA2)/PSK

**Disable** - Turn off the encryption mechanism.

**WEP** - Accept WEP client and the encryption key should be entered in WEP filed below.

**WPA/PSK** - Accepts WPA clients and the encryption key should be entered in PSK.

**WPA2/PSK**-Accepts only WPA2 clients and the encryption key should be entered in PSK.

**Mixed (WPA+WPA2)/PSK** - Accepts WPA and WPA2 clients simultaneously and the encryption key should be entered in PSK.

**WPA**

The WPA encrypts each frame transmitted from the radio using the key, which either PSK entered manually in this field below or automatically negotiated via 802.1x authentication.

**Type** - Select from Mixed (WPA+WPA2) or WPA2 only.

**Pre-Shared Key (PSK)** - Either **8~63** ASCII characters, such as 012345678..(or 64 Hexadecimal digits leading by 0x, such as "0x321253abcde...").

**WEP**

**64-Bit** - For 64 bits WEP key, either **5** ASCII characters, such as 12345 (or 10 hexadecimal digitals leading by 0x, such as 0x4142434445.)

**128-Bit** - For 128 bits WEP key, either **13** ASCII characters, such as ABCDEFGHIJKLM (or 26 hexadecimal digits leading by 0x, such as 0x4142434445464748494A4B4C4D).

Encryption Mode:

All wireless devices must support the same WEP encryption bit size and have the same key. Four keys can be entered here, but only one key can be selected at a time. The keys can be entered in ASCII or Hexadecimal. Check the key you wish to use.

### 3.14.4 Access Control

For additional security of wireless access, the **Access Control** facility allows you to restrict the network access right by controlling the wireless LAN MAC address of client. Only the valid MAC address that has been configured can access the wireless LAN interface. By clicking the **Access Control**, a new web page will appear, as depicted below, so that you could edit the clients' MAC addresses to control their access rights.

Wireless LAN >> Access Control

#### Policy

Select to enable any one of the following policy.  
**Activate MAC address filter-** Allow to set MAC address list for accessing Access Point. PCs with MAC address not listed above cannot access AP. In addition, selected station with MAC address listed above can be isolated from LAN by checking Isolate the station from LAN.

**Blocked MAC address filter-** Allow to set MAC address list for denying access AP. However, stations

with MAC address not listed above are allowed to access AP.

Policy :

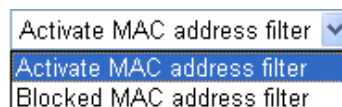

### Enable Mac Access Filter

Select to enable the MAC Address filter for wireless LAN identified with SSID 1 to 4 respectively. All the clients (expressed by MAC addresses) listed in the box can be grouped under different wireless LAN. For example, they can be grouped under SSID 1 and SSID 2 at the same time if you check SSID 1 and SSID 2.

### MAC Address Filter

Display all MAC addresses that are edited before.  
**Client's MAC Address** - Manually enter the MAC address of wireless client.

### Attribute

**s** - select to isolate the wireless connection of the wireless client of the MAC address from LAN.

### Add

Add a new MAC address into the list.

### Delete

Delete the selected MAC address in the list.

### Edit

Edit the selected MAC address in the list.

### Cancel

Give up the access control set up.

### OK

Click it to save the access control list.

### Clear All

Clean all entries in the MAC address list.

## 3.14.5 WPS

**WPS (Wi-Fi Protected Setup)** provides easy procedure to make network connection between wireless station and wireless access point (vigor router) with the encryption of WPA and WPA2.

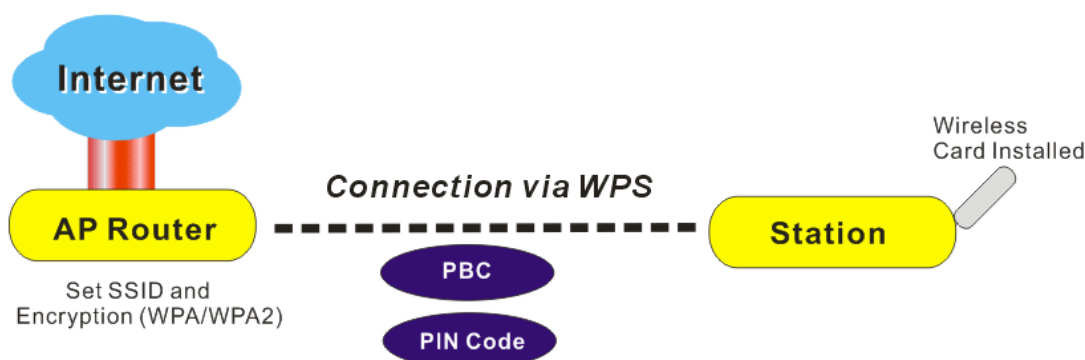

**Note:** Such function is available for the wireless station with WPS supported.

It is the simplest way to build connection between wireless network clients and vigor router. Users do not need to select any encryption mode and type any long encryption passphrase to setup a wireless client every time. He/she only needs to press a button on wireless client, and WPS will connect for client and router automatically.

There are two methods to do network connection through WPS between AP and Stations: pressing the **Start PBC** button or using **PIN Code**.

- On the side of Vigor 2930 series which served as an AP, press **Factory Reset** button once on the front panel of the router or click **Start PBC** on web configuration interface. On the side of a station with network card installed, press **Start PBC** button of network card.

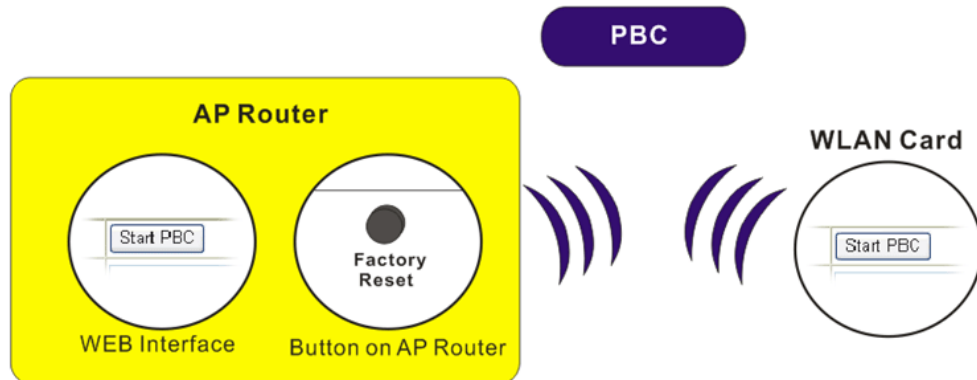

- If you want to use PIN code, you have to know the PIN code specified in wireless client. Then provide the PIN code of the wireless client you wish to connect to the vigor router.

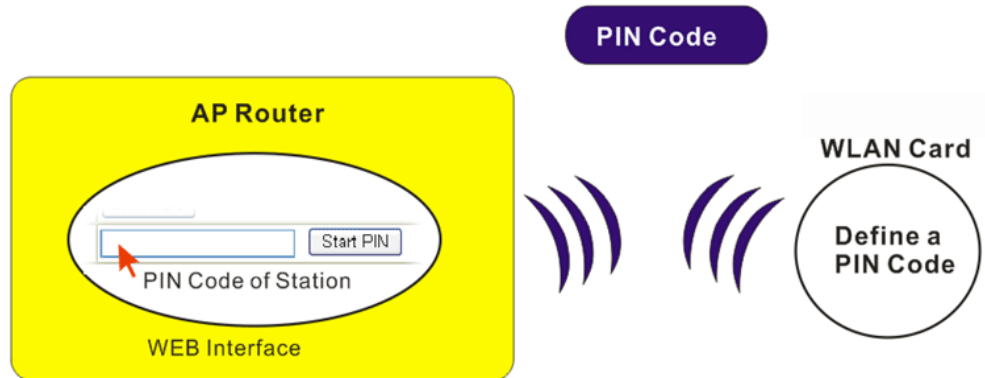

For WPS is supported in WPA-PSK or WPA2-PSK mode, if you do not choose such mode in **Wireless LAN>>Security**, you will see the following message box.

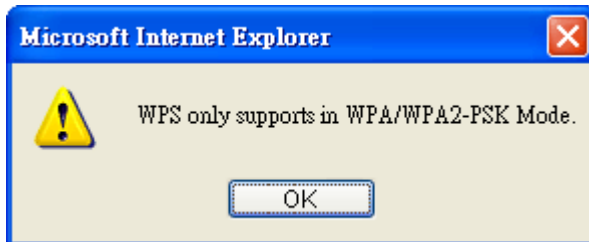

Please click **OK** and go back **Wireless LAN>>Security** to choose WPA-PSK or WPA2-PSK mode and access WPS again.

Below shows **Wireless LAN>>WPS** web page.

## Wireless LAN >> WPS (Wi-Fi Protected Setup)

Enable WPS 

### Wi-Fi Protected Setup Information

<b>WPS Status</b>	Configured
<b>SSID</b>	default
<b>Authentication Mode</b>	WPA/PSK

### Device Configure

<b>Configure via Push Button</b>	<input type="button" value="Start PBC"/>
<b>Configure via Client PinCode</b>	<input type="text"/> <input type="button" value="Start PIN"/>

Status: Ready

**Note:** WPS can help your wireless client automatically connect to the Access point.

 : WPS is Disabled.

 : WPS is Enabled.

 : Waiting for WPS requests from wireless clients.

### Enable WPS

Check this box to enable WPS setting.

### WPS Status

Display related system information for WPS. If the wireless security (encryption) function of the router is properly configured, you can see 'Configured' message here.

### SSID

Display the SSID1 of the router. WPS is supported by SSID1 only.

### Authentication Mode

Display current authentication mode of the router. Only WPA2/PSK and WPA/PSK support WPS.

### Configure via Push Button

Click **Start PBC** to invoke Push-Button style WPS setup procedure. The router will wait for WPS requests from wireless clients about two minutes. The WLAN LED on the router will blink fast when WPS is in progress. It will return to normal condition after two minutes. (You need to setup WPS within two minutes)

### Configure via Client PinCode

Please input the PIN code specified in wireless client you wish to connect, and click **Start PIN** button. The WLAN LED on the router will blink fast when WPS is in progress. It will return to normal condition after two minutes. (You need to setup WPS within two minutes)

## 3.14.6 WDS

WDS means Wireless Distribution System. It is a protocol for connecting two access points (AP) wirelessly. Usually, it can be used for the following application:

- Provide bridge traffic between two LANs through the air.
- Extend the coverage range of a WLAN.

To meet the above requirement, two WDS modes are implemented in Vigor router. One is **Bridge**, the other is **Repeater**. Below shows the function of WDS-bridge interface:

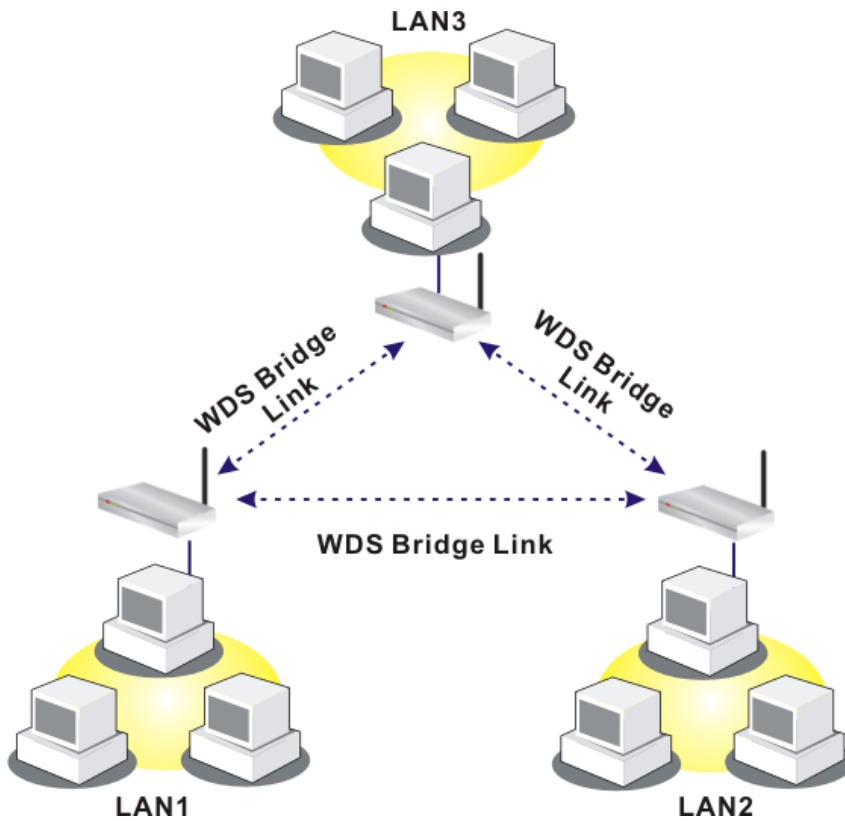

The application for the WDS-Repeater mode is depicted as below:

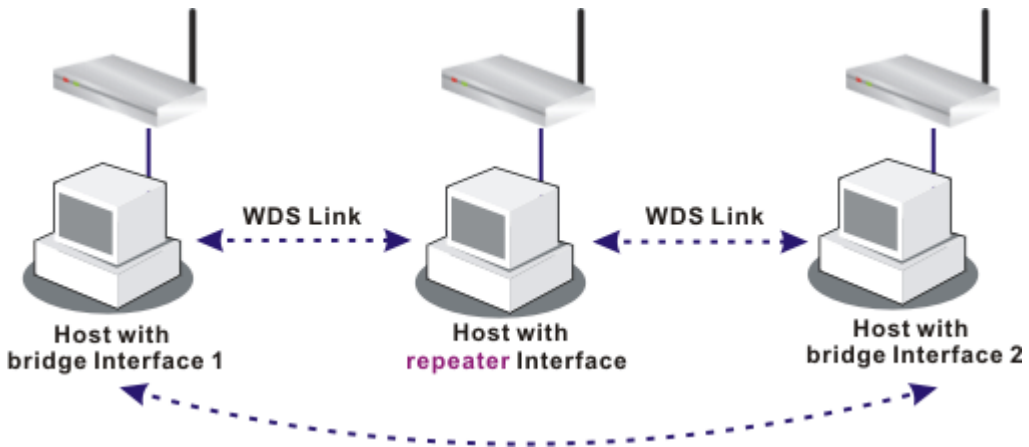

The major difference between these two modes is that: while in **Repeater** mode, the packets received from one peer AP can be repeated to another peer AP through WDS links. Yet in **Bridge** mode, packets received from a WDS link will only be forwarded to local wired or wireless hosts. In other words, only Repeater mode can do WDS-to-WDS packet forwarding.

In the following examples, hosts connected to Bridge 1 or 3 can communicate with hosts connected to Bridge 2 through WDS links. However, hosts connected to Bridge 1 CANNOT communicate with hosts connected to Bridge 3 through Bridge 2.

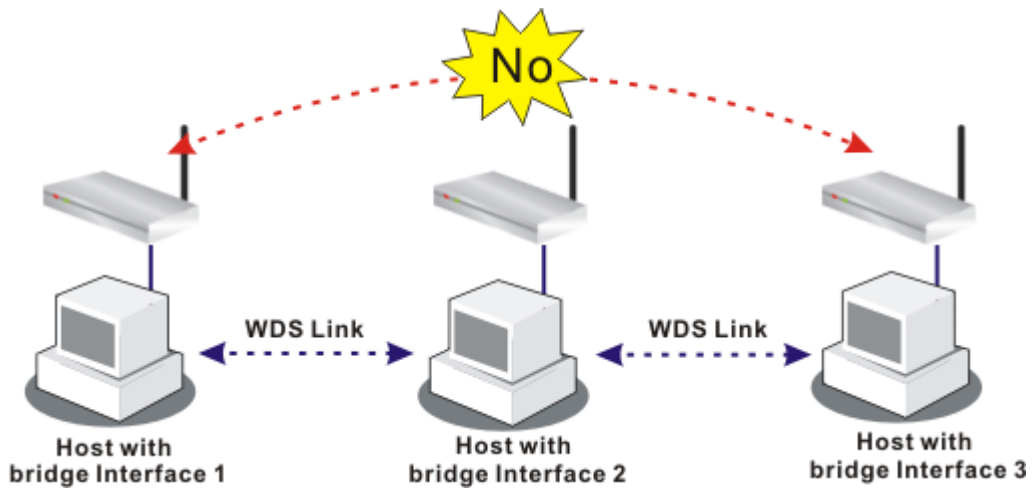

Click **WDS** from **Wireless LAN** menu. The following page will be shown.

Wireless LAN >> WDS Settings

[Set to Factory Default](#)

**WDS Settings**

<p><b>Mode:</b> <span style="border: 1px solid gray; padding: 2px;">Disable</span></p> <hr/> <p><b>Security:</b></p> <p> <input checked="" type="radio"/> Disable           <input type="radio"/> WEP           <input type="radio"/> Pre-shared Key       </p> <hr/> <p><b>WEP:</b></p> <p>Use the same WEP key set in <a href="#">Security Settings</a>.</p> <hr/> <p><b>Pre-shared Key:</b></p> <p>Type : TKIP</p> <p>Key : <span style="border: 1px solid gray; padding: 2px;">*****</span></p> <p><small>Type 8~63 ASCII characters or 64 hexadecimal digits leading by "0x", for example "cfgs01a2..." or "0x655abcd....".</small></p>	<p><b>Bridge</b></p> <p>Enable <input type="checkbox"/>   Peer MAC Address</p> <table style="width: 100%; border-collapse: collapse;"> <tr><td><input type="checkbox"/></td><td><input type="text"/></td><td><input type="text"/></td><td><input type="text"/></td><td><input type="text"/></td><td><input type="text"/></td><td><input type="text"/></td></tr> <tr><td><input type="checkbox"/></td><td><input type="text"/></td><td><input type="text"/></td><td><input type="text"/></td><td><input type="text"/></td><td><input type="text"/></td><td><input type="text"/></td></tr> <tr><td><input type="checkbox"/></td><td><input type="text"/></td><td><input type="text"/></td><td><input type="text"/></td><td><input type="text"/></td><td><input type="text"/></td><td><input type="text"/></td></tr> <tr><td><input type="checkbox"/></td><td><input type="text"/></td><td><input type="text"/></td><td><input type="text"/></td><td><input type="text"/></td><td><input type="text"/></td><td><input type="text"/></td></tr> </table> <p><small>Note: Disable unused links to get better performance.</small></p> <hr/> <p><b>Repeater</b></p> <p>Enable <input type="checkbox"/>   Peer MAC Address</p> <table style="width: 100%; border-collapse: collapse;"> <tr><td><input type="checkbox"/></td><td><input type="text"/></td><td><input type="text"/></td><td><input type="text"/></td><td><input type="text"/></td><td><input type="text"/></td><td><input type="text"/></td></tr> <tr><td><input type="checkbox"/></td><td><input type="text"/></td><td><input type="text"/></td><td><input type="text"/></td><td><input type="text"/></td><td><input type="text"/></td><td><input type="text"/></td></tr> <tr><td><input type="checkbox"/></td><td><input type="text"/></td><td><input type="text"/></td><td><input type="text"/></td><td><input type="text"/></td><td><input type="text"/></td><td><input type="text"/></td></tr> <tr><td><input type="checkbox"/></td><td><input type="text"/></td><td><input type="text"/></td><td><input type="text"/></td><td><input type="text"/></td><td><input type="text"/></td><td><input type="text"/></td></tr> </table> <hr/> <p><b>Access Point Function:</b></p> <p><input checked="" type="radio"/> Enable   <input type="radio"/> Disable</p> <hr/> <p><b>Status:</b></p> <p><input type="checkbox"/> Send "Hello" message to peers.</p> <p style="text-align: center;"><span style="border: 1px solid gray; padding: 2px;">Link Status</span></p> <p><small>Note: The status is valid only when the peer also supports this function.</small></p>	<input type="checkbox"/>	<input type="text"/>	<input type="text"/>	<input type="text"/>	<input type="text"/>	<input type="text"/>	<input type="text"/>	<input type="checkbox"/>	<input type="text"/>	<input type="text"/>	<input type="text"/>	<input type="text"/>	<input type="text"/>	<input type="text"/>	<input type="checkbox"/>	<input type="text"/>	<input type="text"/>	<input type="text"/>	<input type="text"/>	<input type="text"/>	<input type="text"/>	<input type="checkbox"/>	<input type="text"/>	<input type="text"/>	<input type="text"/>	<input type="text"/>	<input type="text"/>	<input type="text"/>	<input type="checkbox"/>	<input type="text"/>	<input type="text"/>	<input type="text"/>	<input type="text"/>	<input type="text"/>	<input type="text"/>	<input type="checkbox"/>	<input type="text"/>	<input type="text"/>	<input type="text"/>	<input type="text"/>	<input type="text"/>	<input type="text"/>	<input type="checkbox"/>	<input type="text"/>	<input type="text"/>	<input type="text"/>	<input type="text"/>	<input type="text"/>	<input type="text"/>	<input type="checkbox"/>	<input type="text"/>	<input type="text"/>	<input type="text"/>	<input type="text"/>	<input type="text"/>	<input type="text"/>
<input type="checkbox"/>	<input type="text"/>	<input type="text"/>	<input type="text"/>	<input type="text"/>	<input type="text"/>	<input type="text"/>																																																			
<input type="checkbox"/>	<input type="text"/>	<input type="text"/>	<input type="text"/>	<input type="text"/>	<input type="text"/>	<input type="text"/>																																																			
<input type="checkbox"/>	<input type="text"/>	<input type="text"/>	<input type="text"/>	<input type="text"/>	<input type="text"/>	<input type="text"/>																																																			
<input type="checkbox"/>	<input type="text"/>	<input type="text"/>	<input type="text"/>	<input type="text"/>	<input type="text"/>	<input type="text"/>																																																			
<input type="checkbox"/>	<input type="text"/>	<input type="text"/>	<input type="text"/>	<input type="text"/>	<input type="text"/>	<input type="text"/>																																																			
<input type="checkbox"/>	<input type="text"/>	<input type="text"/>	<input type="text"/>	<input type="text"/>	<input type="text"/>	<input type="text"/>																																																			
<input type="checkbox"/>	<input type="text"/>	<input type="text"/>	<input type="text"/>	<input type="text"/>	<input type="text"/>	<input type="text"/>																																																			
<input type="checkbox"/>	<input type="text"/>	<input type="text"/>	<input type="text"/>	<input type="text"/>	<input type="text"/>	<input type="text"/>																																																			

OK
Cancel

### Mode

Choose the mode for WDS setting. **Disable** mode will not invoke any WDS setting. **Bridge** mode is designed to fulfill the first type of application. **Repeater** mode is for the second

one.

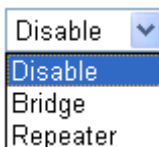

<b>Security</b>	There are three types for security, <b>Disable</b> , <b>WEP</b> and <b>Pre-shared key</b> . The setting you choose here will make the following WEP or Pre-shared key field valid or not. Choose one of the types for the router.
<b>WEP</b>	Use the same key set in <b>Security Settings</b> page.
<b>Pre-shared Key</b>	Type 8 ~ 63 ASCII characters or 64 hexadecimal digits leading by "0x".
<b>Bridge</b>	If you choose Bridge as the connecting mode, please type in the peer MAC address in these fields. <b>Six</b> peer MAC addresses are allowed to be entered in this page at one time. Yet please disable the unused link to get better performance. If you want to invoke the peer MAC address, remember to check <b>Enable</b> box in the front of the MAC address after typing.
<b>Repeater</b>	If you choose Repeater as the connecting mode, please type in the peer MAC address in these fields. Two peer MAC addresses are allowed to be entered in this page at one time. Similarly, if you want to invoke the peer MAC address, remember to check <b>Enable</b> box in the front of the MAC address after typing.
<b>Access Point Function</b>	Click <b>Enable</b> to make this router serving as an access point; click <b>Disable</b> to cancel this function.
<b>Status</b>	It allows user to send "hello" message to peers. Yet, it is valid only when the peer also supports this function.

### 3.14.6 AP Discovery

Vigor router can scan all regulatory channels and find working APs in the neighborhood. Based on the scanning result, users will know which channel is clean for usage. Also, it can be used to facilitate finding an AP for a WDS link. Notice that during the scanning process (about 5 seconds), no client is allowed to connect to Vigor.

This page is used to scan the existence of the APs on the wireless LAN. Yet, only the AP which is in the same channel of this router can be found. Please click **Scan** to discover all the connected APs.



Access Point List

BSSID	Channel	SSID

See [Statistics](#).

**Note:** During the scanning process (~5 seconds), no station is allowed to connect with the router.

---

**Add to [WDS Settings](#) :**

AP's MAC address       :  :  :  :  :

      Bridge       Repeater

If you want the found AP applying the WDS settings, please type in the AP's MAC address on the bottom of the page and click Bridge or Repeater. Next, click **Add to**. Later, the MAC address of the AP will be added to Bridge or Repeater field of WDS settings page.

### 3.14.7 Station List

**Station List** provides the knowledge of connecting wireless clients now along with its status code. There is a code summary below for explanation. For convenient **Access Control**, you can select a WLAN station and click **Add to Access Control** below.

Station List

Status	MAC Address	Associated with

**Status Codes :**  
**C:** Connected, No encryption.  
**E:** Connected, WEP.  
**P:** Connected, WPA.  
**A:** Connected, WPA2.  
**B:** Blocked by Access Control.  
**N:** Connecting.  
**F:** Fail to pass WPA/PSK authentication.

**Note:** After a station connects to the router successfully, it may be turned off without notice. In that case, it will still be on the list until the connection expires.

---

**Add to Access Control :**

Client's MAC address     :  :  :  :  :

**Refresh**

Click this button to refresh the status of station list.

**Add**

Click this button to add current selected MAC address into **Access Control**.

### 3.14.8 Rate Control

This page allows you to control the upload and download rate of each wireless client (station) and SSID1-4. Please check the box of **Enable** to invoke this setting. The range for the rate is between 100 ~ 100,000 kbps.

**Station Rate Control**

Enable

Upload Rate :  Kbps

Download Rate :  Kbps

**Note:**  
 1. Range: 100~100,000 Kbps, Increment: 100 Kbps.  
 2. The specified rates are applied to each associated wireless client.

**SSID Rate Control**

	Enable	Upload	Download
SSID 1	<input type="checkbox"/>	<input type="text" value="100000"/> kbps	<input type="text" value="100000"/> kbps
SSID 2	<input type="checkbox"/>	<input type="text" value="100000"/> kbps	<input type="text" value="100000"/> kbps
SSID 3	<input type="checkbox"/>	<input type="text" value="100000"/> kbps	<input type="text" value="100000"/> kbps
SSID 4	<input type="checkbox"/>	<input type="text" value="100000"/> kbps	<input type="text" value="100000"/> kbps

**Note:**  
 1. Range: 100~100,000 Kbps, Increment: 100 Kbps.  
 2. The specified rates are shared by all clients associate with the same SSID.

SSID rate control controls the data transmission rate through wireless connection.

**Enable** Check **Enable** for typing upload and download rate.

**Upload** Type the transmitting rate for data upload. Default value is 30,000 kbps.

**Download** Type the transmitting rate for data download. Default value is 30,000 kbps.

### 3.15 SSL VPN

An SSL VPN (Secure Sockets Layer virtual private network) is a form of VPN that can be used with a standard Web browser.

There are two benefits that SSL VPN provides:

- It is not necessary for users to preinstall VPN client software for executing SSL VPN connection.
- There are less restrictions for the data encrypted through SSL VPN in comparing with traditional VPN.

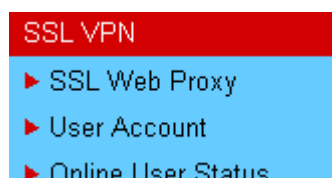

#### 3.15.1 SSL Web Proxy

SSL Web Proxy will allow the remote users to access the internal web sites over SSL.

SSL Web Proxy Servers Profiles: | [Set to Factory Default](#) |

Index	Name	URL	Active
<a href="#">1.</a>			x
<a href="#">2.</a>			x
<a href="#">3.</a>			x
<a href="#">4.</a>			x
<a href="#">5.</a>			x
<a href="#">6.</a>			x
<a href="#">7.</a>			x
<a href="#">8.</a>			x
<a href="#">9.</a>			x
<a href="#">10.</a>			x
<a href="#">11.</a>			x
<a href="#">12.</a>			x
<a href="#">13.</a>			x
<a href="#">14.</a>			x
<a href="#">15.</a>			x
<a href="#">16.</a>			x
<a href="#">17.</a>			x

- Name** Display the name of the profile that you create.
- URL** Display the URL.
- Active** Display current status (active or inactive) of such profile.

Click number link under Index filed to set detailed configuration.

**Profile Index : 1**

Name

URL

Host IP Address

Access Method Disable ▾

**Note:** URL format must be entered as http://Domain\_name/directory where Domain\_name is a FQDN.

- Name** Type name of the profile.
- URL** Type the address (function variation or IP address) or path of the proxy server.
- Host IP Address** If you type function variation as URL, you have to type corresponding IP address in this filed. Such field must match with URL setting.
- Access Method** There are three modes for you to choose
  - Disable** – the profile will be inactive. If you choose **Disable**, all the web proxy profile appeared under VPN remote dial-in web page will disappear.
  - Secured Port Redirection** – such technique applies private port mapping to random WAN port. There are two restrictions for proxy web server for such selection: 1) it is only used for

WAN to LAN access, the web server must be configured behind vigor router; 2) web server gateway must be indicated to vigor router. In addition, users must execute “Connect” manually in SSL Client Portal page.

**SSL** – if you choose such selection, web proxy over SSL will be applied for VPN.

### 3.15.2 User Account

For SSL VPN, identity authentication and power management are implemented through deploying user accounts. Therefore, the user account for SSL VPN must be set together with remote dial-in user web page. Such menu item will guide to access into **VPN and Remote Access>>Remote Dial-in user**. For the detailed configuration of user account, please refer to section 3.10.5.

VPN and Remote Access >> Remote Dial-in User

Remote Access User Accounts: | [Set to Factory Default](#) |

Index	User	Status	Index	User	Status
<a href="#">1.</a>	???	×	<a href="#">17.</a>	???	×
<a href="#">2.</a>	???	×	<a href="#">18.</a>	???	×
<a href="#">3.</a>	???	×	<a href="#">19.</a>	???	×
<a href="#">4.</a>	???	×	<a href="#">20.</a>	???	×
<a href="#">5.</a>	???	×	<a href="#">21.</a>	???	×
<a href="#">6.</a>	???	×	<a href="#">22.</a>	???	×
<a href="#">7.</a>	???	×	<a href="#">23.</a>	???	×
<a href="#">8.</a>	???	×	<a href="#">24.</a>	???	×
<a href="#">9.</a>	???	×	<a href="#">25.</a>	???	×
<a href="#">10.</a>	???	×	<a href="#">26.</a>	???	×
<a href="#">11.</a>	???	×	<a href="#">27.</a>	???	×
<a href="#">12.</a>	???	×	<a href="#">28.</a>	???	×
<a href="#">13.</a>	???	×	<a href="#">29.</a>	???	×
<a href="#">14.</a>	???	×	<a href="#">30.</a>	???	×
<a href="#">15.</a>	???	×	<a href="#">31.</a>	???	×
<a href="#">16.</a>	???	×	<a href="#">32.</a>	???	×

<< [1-32](#) | [33-64](#) | [65-96](#) | [97-100](#) >> [Next](#) >>

You can find out the link of Set SSL Web Proxy on the profile setting page. If you haven't set any SSL Web Proxy Profile in **SSL VPN>>SSL Web Proxy** web page, there is no check box but a link appeared below.

or Peer ID

Netbios Naming Packet  Pass  Block

**SSL VPN**

[Set SSL Web Proxy](#)

Local ID  (optional)

**Callback Function**

Check to enable Callback function

Specify the callback number

Callback Number

Check to enable Callback Budget Control

Callback Budget  minute(s)

OK Clear Cancel

However, if you have set several SSL Web Proxy Profiles in **SSL VPN>>SSL Web Proxy** web page:

**SSL Web Proxy Servers Profiles:**

Index	Name	URL
<u>1.</u>	gforge	http://swm.draytek.com
<u>2.</u>	web	http://www.draytek.com.cn
<u>3.</u>		
<u>4.</u>		

The SSL Web Proxy profile names will be displayed (together with check box) as shown below.

Netbios Naming Packet  Pass  Block

**SSL VPN**

SSL Web Proxy

gforge (Secured Port Redirection)

web (SSL)

**Callback Function**

Check to enable Ca

Specify the call

Callback Number

Check to enable

Callback Budget

OK Clear Cancel

### 3.15.3 Online User Status

If you have finished the configuration of SSL Web Proxy (server), users can find out corresponding settings when they access into Draytek SSL VPN portal interface.



Provide SSL VPN

Home SSL Web Proxy SSL Tunnel [ [logout](#) ]

**INFO**

**mike**,  
(172.17.1.42)  
Welcome to DrayTek  
SSL VPN!

Timeout after 5 minutes.  
[ [Reset](#) ]

Main Page:

You have successfully logged in!  
You are given the following privileges:

- [SSL Web Proxy](#)
- [SSL Tunnel](#)

Copyright © 2006, DrayTek Corp. All Rights Reserved.

Next, users can open **SSL VPN>> Online Status** to view logging status of SSL VPN.

Web Access Control >> Online User Status

Refresh Seconds : 10

Active User	Host IP	Time out(seconds)	Action
caesar	172.17.1.42	292	<input type="button" value="Drop"/>

**Active User** Display current user who visit SSL VPN server.

**Host IP** Displays the IP address for the host.

**Time out** Display the time remaining for logging out.

**Action** You can click **Drop** to drop certain login user from the router's SSL Portal UI.

## 3.16 System Maintenance

For the system setup, there are several items that you have to know the way of configuration: Status, Administrator Password, Configuration Backup, Syslog, Time setup, Reboot System, Firmware Upgrade.

Below shows the menu items for System Maintenance.

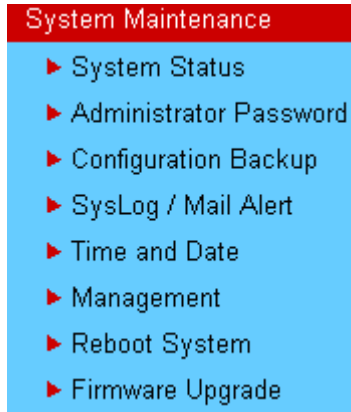

### 3.16.1 System Status

The **System Status** provides basic network settings of Vigor router. It includes LAN and WAN interface information. Also, you could get the current running firmware version or firmware related information from this presentation.

#### System Status

**Model Name** : VigorPro5300 series  
**Firmware Version** : 3.3.1\_RC1  
**Build Date/Time** : Apr 11 2008 11:08:09  
**Signature Version** : basic  
**Signature Build Date** : Tue Aug 29 09:16:25.00 2006

LAN	
MAC Address	: 00-50-7F-22-33-44
1st IP Address	: 192.168.1.1
1st Subnet Mask	: 255.255.255.0
DHCP Server	: Yes
DNS	: 194.109.6.66

VoIP			
Port	Profile	Reg.	In/Out
Phone1		No	0/0
Phone2		No	0/0
ISDN1-S0		No	0/0
ISDN2-TE		No	0/0

WAN 1	
Link Status	: <b>Connected</b>
MAC Address	: 00-50-7F-22-33-45
Connection	: Static IP
IP Address	: 172.16.3.229
Default Gateway	: 172.16.3.4
Mode	: NAT

WAN 2	
Link Status	: <b>Disconnected</b>
MAC Address	: 00-50-7F-22-33-46
Connection	: ---
IP Address	: ---
Default Gateway	: ---
Mode	: NAT

Wireless LAN	
MAC Address	: 00-50-7f-22-33-44
Frequency Domain	: Europe
Firmware Version	: v1.04.11.09.7.5
SSID	: default

<b>Model Name</b>	Display the model name of the router.
<b>Firmware Version</b>	Display the firmware version of the router.
<b>Build Date/Time</b>	Display the date and time of the current firmware build.
<b>MAC Address</b>	Display the MAC address of the LAN Interface.



<b>1<sup>st</sup> IP Address</b>	Display the IP address of the LAN interface.
<b>1<sup>st</sup> Subnet Mask</b>	Display the subnet mask address of the LAN interface.
<b>DHCP Server</b>	Display the current status of DHCP server of the LAN interface.
<b>DNS</b>	Display the assigned IP address of the primary DNS.
<b>Link Status</b>	Display the connection status of WAN interface.
<b>MAC Address</b>	Display the MAC address of the WAN Interface.
<b>Connection</b>	Display the chosen WAN mode.
<b>IP Address</b>	Display the IP address of the WAN interface.
<b>Default Gateway</b>	Display the assigned IP address of the default gateway.
<b>DNS</b>	Display the assigned IP address of the primary DNS.
<b>MAC Address</b>	Display the MAC address of the wireless LAN.
<b>Frequency Domain</b>	It can be Europe (13 usable channels), USA (11 usable channels) etc. The available channels supported by the wireless products in different countries are various.
<b>Firmware Version</b>	It indicates information about equipped WLAN miniPCi card. This also helps to provide availability of some features that are bound with some WLAN miniPCi card.

### 3.16.2 Administrator Password

This page allows you to set new password.

System Maintenance >> Administrator Password Setup

**Administrator Password**

Old Password	<input style="width: 90%;" type="text"/>
New Password	<input style="width: 90%;" type="text"/>
Confirm Password	<input style="width: 90%;" type="text"/>

**Old Password** Type in the old password. The factory default setting for password is blank.

**New Password** Type in new password in this field.

**Confirm Password** Type in the new password again.

When you click OK, the login window will appear. Please use the new password to access into the web configurator again.

### 3.16.3 Configuration Backup

#### Backup the Configuration

Follow the steps below to backup your configuration.

1. Go to **System Maintenance >> Configuration Backup**. The following windows will be popped-up, as shown below.

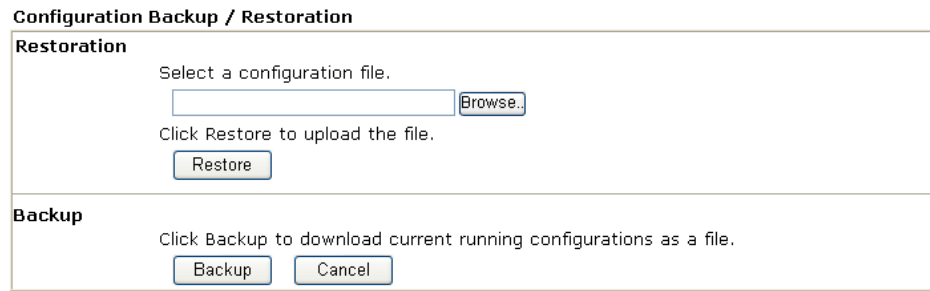

2. Click **Backup** button to get into the following dialog. Click **Save** button to open another dialog for saving configuration as a file.

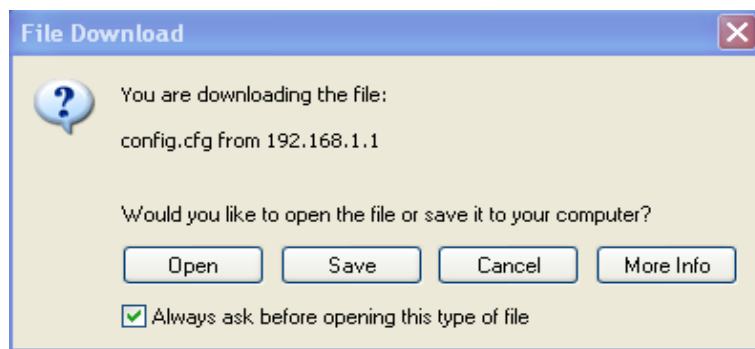

3. In **Save As** dialog, the default filename is **config.cfg**. You could give it another name by yourself.

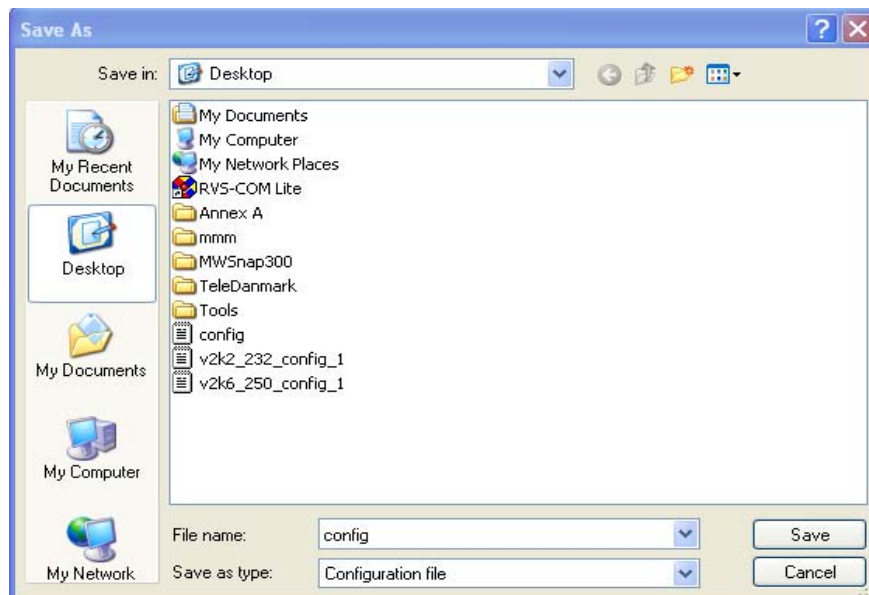

4. Click **Save** button, the configuration will download automatically to your computer as a file named **config.cfg**.

The above example is using **Windows** platform for demonstrating examples. The **Mac** or **Linux** platform will appear different windows, but the backup function is still available.

**Note:** Backup for Certification must be done independently. The Configuration Backup does not include information of Certificate.

## Restore Configuration

1. Go to **System Maintenance >> Configuration Backup**. The following windows will be popped-up, as shown below.

System Maintenance >> Configuration Backup

**Configuration Backup / Restoration**

**Restoration**

Select a configuration file.

Click Restore to upload the file.

**Backup**

Click Backup to download current running configurations as a file.

2. Click **Browse** button to choose the correct configuration file for uploading to the router.
3. Click **Restore** button and wait for few seconds, the following picture will tell you that the restoration procedure is successful.

## 3.16.4 Syslog/Mail Alert

SysLog function is provided for users to monitor router. There is no bother to directly get into the Web Configurator of the router or borrow debug equipments.

System Maintenance >> SysLog / Mail Alert Setup

**SysLog / Mail Alert Setup**

**SysLog Access Setup**

Enable

Router Name

Server IP Address

Destination Port

Enable syslog message:

- Firewall Log
- VPN Log
- User Access Log
- Call Log
- WAN Log
- Router/DSL information

**Mail Alert Setup**

Enable

SMTP Server

Mail To

Return-Path

Authentication

User Name

Password

Enable E-Mail Alert:

- DoS Attack
- IM-P2P
- Anti-Intrusion
- Anti-Virus

- |                                  |   |
|----------------------------------|---|
| <b>Enable (Syslog Access...)</b> | Check “ <b>Enable</b> ” to activate function of syslog.   |
| <b>Syslog Server IP</b>          | The IP address of the Syslog server.  |
| <b>Destination Port</b>          | Assign a port for the Syslog protocol.  |
| <b>Enable syslog message</b>     | Check the box listed on this web page to send the corresponding message of firewall, VPN, User Access, Call, WAN, Router/DSL information to Syslog. |
| <b>Enable (Alert Setup...)</b>   | Check “ <b>Enable</b> ” to activate function of mail alert.   |

<b>Send a test e-mail</b>	Make a simple test for the e-mail address specified in this page. Please assign the mail address first and click this button to execute a test for verify the mail address is available or not.
<b>SMTP Server</b>	The IP address of the SMTP server.
<b>Mail To</b>	Assign a mail address for sending mails out.
<b>Return-Path</b>	Assign a path for receiving the mail from outside.
<b>Authentication</b>	Check this box to activate this function while using e-mail application.
<b>User Name</b>	Type the user name for authentication.
<b>Password</b>	Type the password for authentication.
<b>Enable E-mail Alert</b>	Check the box to send alert message to the e-mail box while the router detecting the item(s) you specify here.

Click **OK** to save these settings.

For viewing the Syslog, please do the following:

1. Just set your monitor PC's IP address in the field of Server IP Address
2. Install the Router Tools in the **Utility** within provided CD. After installation, click on the **Router Tools>>Syslog** from program menu.

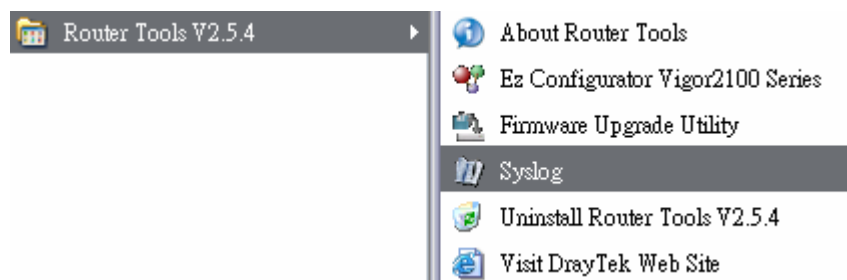

3. From the Syslog screen, select the router you want to monitor. Be reminded that in **Network Information**, select the network adapter used to connect to the router. Otherwise, you won't succeed in retrieving information from the router.

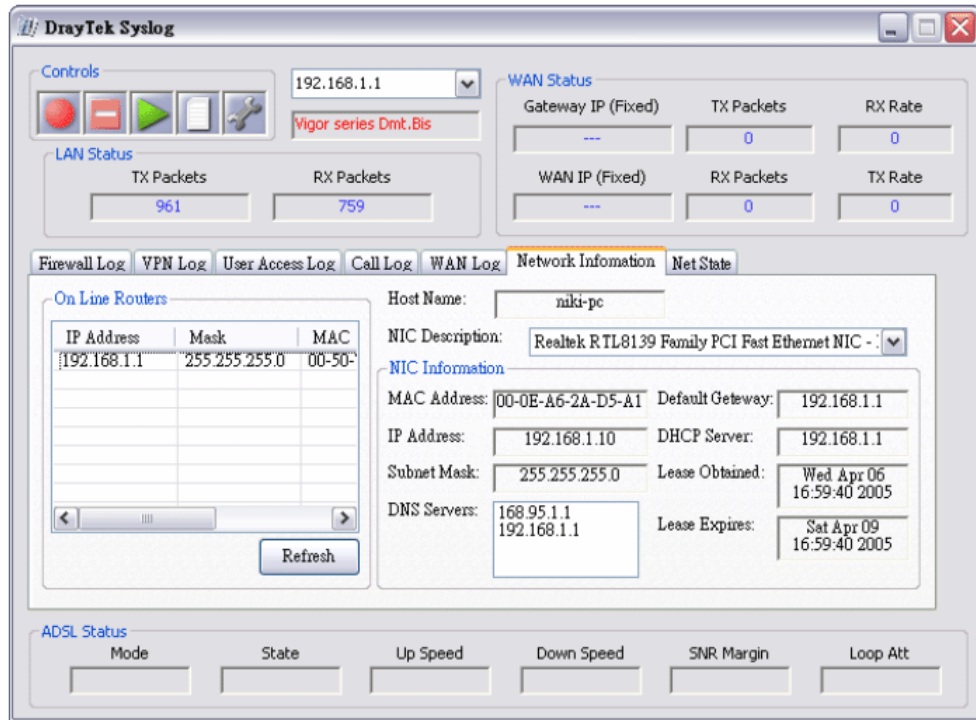

### 3.16.5 Time and Date

It allows you to specify where the time of the router should be inquired from.

System Maintenance >> Time and Date

**Time Information**

Current System Time	2006 Sep 5 Tue 6 : 44 : 17	Inquire Time
---------------------	----------------------------	--------------

**Time Setup**

<input type="radio"/> Use Browser Time	
<input checked="" type="radio"/> Use Internet Time Client	
Time Protocol	NTP (RFC-1305) ▾
Server IP Address	pool.ntp.org
Time Zone	(GMT) Greenwich Mean Time : Dublin ▾
Enable Daylight Saving	<input type="checkbox"/>
Automatically Update Interval	30 min ▾

OK Cancel

**Current System Time**

Click **Inquire Time** to get the current time.

**Use Browser Time**

Select this option to use the browser time from the remote administrator PC host as router's system time.

**Use Internet Time**

Select to inquire time information from Time Server on the Internet using assigned protocol.

**Time Protocol**

Select a time protocol.

**Server IP Address**

Type the IP address of the time server.

**Time Zone**

Select the time zone where the router is located.

**Automatically Update Interval**

Select a time interval for updating from the NTP server.

Click **OK** to save these settings.

### 3.16.6 Management

This page allows you to manage the settings for access control, access list, port setup, and SNMP setup. For example, as to management access control, the port number is used to send/receive SIP message for building a session. The default value is 5060 and this must match with the peer Registrar when making VoIP calls.

System Maintenance >> Management

**Management Setup**

<p><b>Management Access Control</b></p> <p><input type="checkbox"/> Allow management from the Internet</p> <p style="margin-left: 20px;"><input type="checkbox"/> FTP Server</p> <p style="margin-left: 20px;"><input checked="" type="checkbox"/> HTTP Server</p> <p style="margin-left: 20px;"><input checked="" type="checkbox"/> HTTPS Server</p> <p style="margin-left: 20px;"><input checked="" type="checkbox"/> Telnet Server</p> <p><input checked="" type="checkbox"/> Disable PING from the Internet</p> <p><input checked="" type="checkbox"/> External Device Auto Discovery</p> <hr/> <p><b>Access List</b></p> <table style="width: 100%; border-collapse: collapse;"> <thead> <tr> <th style="text-align: left;">List</th> <th style="text-align: left;">IP</th> <th style="text-align: left;">Subnet Mask</th> </tr> </thead> <tbody> <tr> <td>1</td> <td><input style="width: 100%;" type="text"/></td> <td><input style="width: 100%;" type="text"/></td> </tr> <tr> <td>2</td> <td><input style="width: 100%;" type="text"/></td> <td><input style="width: 100%;" type="text"/></td> </tr> <tr> <td>3</td> <td><input style="width: 100%;" type="text"/></td> <td><input style="width: 100%;" type="text"/></td> </tr> </tbody> </table>	List	IP	Subnet Mask	1	<input style="width: 100%;" type="text"/>	<input style="width: 100%;" type="text"/>	2	<input style="width: 100%;" type="text"/>	<input style="width: 100%;" type="text"/>	3	<input style="width: 100%;" type="text"/>	<input style="width: 100%;" type="text"/>	<p><b>Management Port Setup</b></p> <p><input checked="" type="radio"/> User Define Ports    <input type="radio"/> Default Ports</p> <p>Telnet Port    <input style="width: 50px;" type="text" value="23"/> (Default: 23)</p> <p>HTTP Port    <input style="width: 50px;" type="text" value="80"/> (Default: 80)</p> <p>HTTPS Port    <input style="width: 50px;" type="text" value="443"/> (Default: 443)</p> <p>FTP Port    <input style="width: 50px;" type="text" value="21"/> (Default: 21)</p> <hr/> <p><b>SNMP Setup</b></p> <p><input type="checkbox"/> Enable SNMP Agent</p> <p>Get Community    <input style="width: 100%;" type="text" value="public"/></p> <p>Set Community    <input style="width: 100%;" type="text" value="private"/></p> <p>Manager Host IP    <input style="width: 100%;" type="text"/></p> <p>Trap Community    <input style="width: 100%;" type="text" value="public"/></p> <p>Notification Host IP    <input style="width: 100%;" type="text"/></p> <p>Trap Timeout    <input style="width: 50px;" type="text" value="10"/> seconds</p>
List	IP	Subnet Mask											
1	<input style="width: 100%;" type="text"/>	<input style="width: 100%;" type="text"/>											
2	<input style="width: 100%;" type="text"/>	<input style="width: 100%;" type="text"/>											
3	<input style="width: 100%;" type="text"/>	<input style="width: 100%;" type="text"/>											

**Allow management from the Internet**

Enable the checkbox to allow system administrators to login from the Internet. There are several servers provided by the system to allow you managing the router from Internet. Check the box(es) to specify.

**Disable PING from the Internet**

Check the checkbox to reject all PING packets from the Internet. For security issue, this function is enabled by default.

**External Device Auto Discovery**

Check the checkbox to detect external devices connected to current router automatically.

**Access List**

You could specify that the system administrator can only login from a specific host or network defined in the list. A maximum of three IPs/subnet masks is allowed.  
**List IP** - Indicate an IP address allowed to login to the router.  
**Subnet Mask** - Represent a subnet mask allowed to login to the router.

**User Define Ports**

Check to specify user-defined port numbers for the Telnet and HTTP servers.

**Default Ports**

Check to use standard port numbers for the Telnet and HTTP servers.

**Enable SNMP Agent**

Check it to enable this function.

**Get Community**

Set the name for getting community by typing a proper character. The default setting is **public**.

<b>Set Community</b>	Set community by typing a proper name. The default setting is <b>private</b> .
<b>Manager Host IP</b>	Set one host as the manager to execute SNMP function. Please type in IP address to specify certain host.
<b>Trap Community</b>	Set trap community by typing a proper name. The default setting is <b>public</b> .
<b>Notification Host IP</b>	Set the IP address of the host that will receive the trap community.
<b>Trap Timeout</b>	The default setting is 10 seconds.

### 3.16.7 Reboot System

The Web Configurator may be used to restart your router. Click **Reboot System** from **System Maintenance** to open the following page.

System Maintenance >> Reboot System

**Reboot System**

**Do You want to reboot your router ?**

Using current configuration  
 Using factory default configuration

If you want to reboot the router using the current configuration, check **Using current configuration** and click **OK**. To reset the router settings to default values, check **Using factory default configuration** and click **OK**. The router will take 5 seconds to reboot the system.

**Note:** When the system pops up Reboot System web page after you configure web settings, please click **OK** to reboot your router for ensuring normal operation and preventing unexpected errors of the router in the future.



### 3.16.8 Firmware Upgrade

Before upgrading your router firmware, you need to install the Router Tools. The **Firmware Upgrade Utility** is included in the tools. The following web page will guide you to upgrade firmware by using an example. Note that this example is running over Windows OS (Operating System).

Download the newest firmware from DrayTek's web site or FTP site. The DrayTek web site is [www.draytek.com](http://www.draytek.com) (or local DrayTek's web site) and FTP site is <ftp.draytek.com>.

Click **System Maintenance>> Firmware Upgrade** to launch the Firmware Upgrade Utility.

System Maintenance >> Firmware Upgrade

---

#### Web Firmware Upgrade

Select a firmware file.

  
Click Upgrade to upload the file. 

#### TFTP Firmware Upgrade from LAN

Current Firmware Version: 3.3.1\_RC1

**Firmware Upgrade Procedures:**

1. Click "OK" to start the TFTP server.
2. Open the Firmware Upgrade Utility or other 3-party TFTP client software.
3. Check that the firmware filename is correct.
4. Click "Upgrade" on the Firmware Upgrade Utility to start the upgrade.
5. After the upgrade is complete, the TFTP server will automatically stop running.

Do you want to upgrade firmware ?

Click **OK**. The following screen will appear. Please execute the firmware upgrade utility first.

System Maintenance >> Firmware Upgrade

---

 TFTP server is running. Please execute a Firmware Upgrade Utility software to upgrade router's firmware. This server will be closed by itself when the firmware upgrading finished.

For the detailed information about firmware update, please go to Chapter 4.

## 3.17 Diagnostics

Diagnostic Tools provide a useful way to **view** or **diagnose** the status of your Vigor router. Below shows the menu items for Diagnostics.

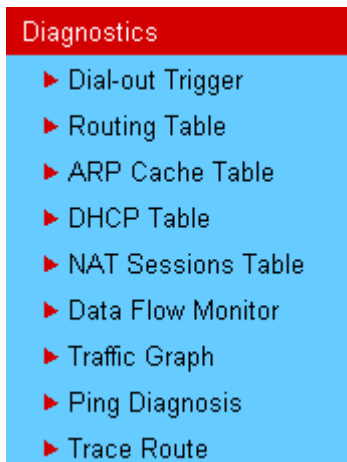

### 3.17.1 Dial-out Trigger

Click **Diagnostics** and click **Dial-out Trigger** to open the web page. The internet connection (e.g., ISDN, PPPoE, PPPoA, etc) is triggered by a package sending from the source IP address.

Diagnostics >> Dial-out Trigger

**Dial-out Triggered Packet Header** | [Refresh](#) |

**HEX Format:**

```
00 00 00 00 00 00 00-00 00 00 00 00 00-00 00
```

```
00 00 00 00 00 00 00 00 00-00 00 00 00 00 00 00
00 00 00 00 00 00 00 00 00-00 00 00 00 00 00 00
00 00 00 00 00 00 00 00 00-00 00 00 00 00 00 00
00 00 00 00 00 00 00 00 00-00 00 00 00 00 00 00
00 00 00 00 00 00 00 00 00-00 00 00 00 00 00 00
```

---

**Decoded Format:**

```
0.0.0.0 -> 0.0.0.0
Pr 0 len 0 (0)
```

**Decoded Format**

It shows the source IP address (local), destination IP (remote) address, the protocol and length of the package.

**Refresh**

Click it to reload the page.

### 3.17.2 Routing Table

Click **Diagnostics** and click **Routing Table** to open the web page.

Diagnostics >> View Routing Table

Current Running Routing Table Refresh

Key: C - connected, S - static, R - RIP, * - default, ~ - private			
*	0.0.0.0/	0.0.0.0 via 172.16.3.1,	WAN1
C~	192.168.1.0/	255.255.255.0 is directly connected,	LAN
C	172.16.3.0/	255.255.255.0 is directly connected,	WAN1

**Refresh**

Click it to reload the page.

### 3.17.3 ARP Cache Table

Click **Diagnostics** and click **ARP Cache Table** to view the content of the ARP (Address Resolution Protocol) cache held in the router. The table shows a mapping between an Ethernet hardware address (MAC Address) and an IP address.

Diagnostics >> View ARP Cache Table

Ethernet ARP Cache Table Clear Refresh

IP Address	MAC Address
192.168.1.10	00-0E-A6-2A-D5-A1
172.16.3.19	00-0D-60-6F-89-CA
172.16.3.163	00-50-7F-1A-58-89
172.16.3.156	00-50-7F-1A-56-0E
172.16.3.153	00-50-7F-1A-57-07
172.16.3.131	00-07-40-82-14-EF
172.16.3.112	00-40-CA-6B-56-BA
172.16.3.114	00-0E-A6-4F-10-C4
172.16.3.8	00-11-25-22-66-22
172.16.3.181	00-50-7F-1A-58-CF
172.16.3.198	00-50-7F-1A-57-AE
172.16.3.174	00-0C-6E-5E-C8-60
172.16.3.160	00-0E-A6-5C-5C-D9
172.16.3.188	00-E0-18-72-AE-11
172.16.3.20	00-0D-60-6F-83-BC

**Refresh**

Click it to reload the page.

**Clear**

Click it to clear the whole table.

### 3.17.4 DHCP Table

The facility provides information on IP address assignments. This information is helpful in diagnosing network problems, such as IP address conflicts, etc.

Click **Diagnostics** and click **DHCP Table** to open the web page.

Diagnostics >> View DHCP Assigned IP Addresses

Index	IP Address	MAC Address	Leased Time	HOST ID
1	192.168.1.10	00-0E-A6-2A-D5-A1	0:00:02.630	ok-lccgjyiy075u

<b>Index</b>	It displays the connection item number.
<b>IP Address</b>	It displays the IP address assigned by this router for specified PC.
<b>MAC Address</b>	It displays the MAC address for the specified PC that DHCP assigned IP address for it.
<b>Leased Time</b>	It displays the leased time of the specified PC.
<b>HOST ID</b>	It displays the host ID name of the specified PC.
<b>Refresh</b>	Click it to reload the page.

### 3.17.5 NAT Sessions Table

Click **Diagnostics** and click **NAT Sessions Table** to open the setup page.

Diagnostics >> NAT Sessions Table

Private IP :Port	#Pseudo Port	Peer IP :Port	Interface
192.168.1.10 2461	52047	207.46.3.12 80	WAN1

<b>Private IP:Port</b>	It indicates the source IP address and port of local PC.
<b>#Pseudo Port</b>	It indicates the temporary port of the router used for NAT.
<b>Peer IP :Port</b>	It indicates the destination IP address and port of remote host.

**Interface** It indicates the interface of the WAN connection.

**Refresh** Click it to reload the page.

### 3.17.6 Data Flow Monitor

This page displays the running procedure for the IP address monitored and refreshes the data in an interval of several seconds. The IP address listed here is configured in Bandwidth Management. You have to enable IP bandwidth limit and IP session limit before invoke Data Flow Monitor. If not, a notification dialog box will appear to remind you enabling it.

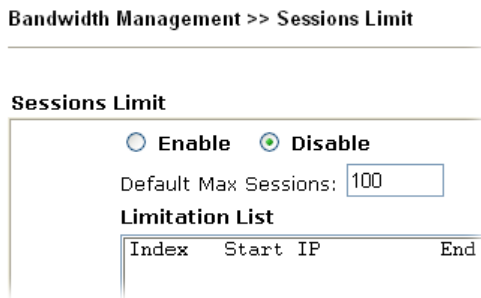

Click **Diagnostics** and click **Data Flow Monitor** to open the web page. You can click **IP Address**, **TX rate**, **RX rate** or **Session** link for arranging the data display.

Diagnostics >> Data Flow Monitor

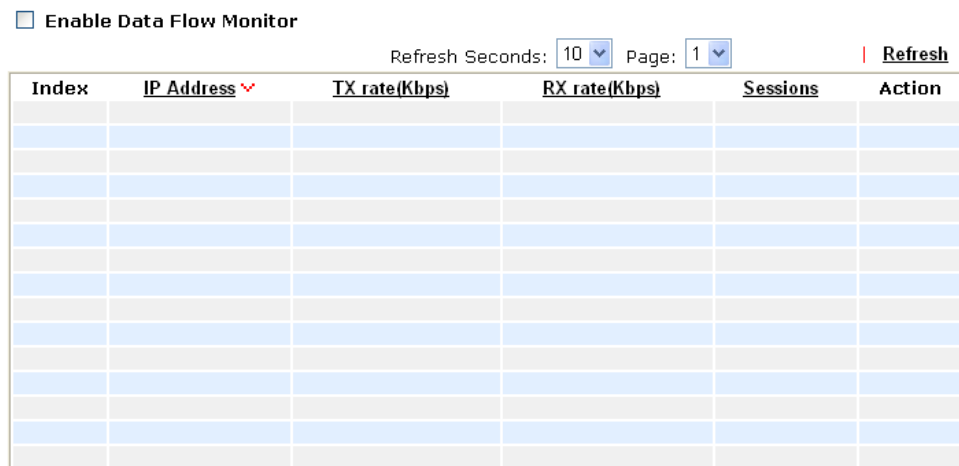

**Note:** 1. Click "Block" to prevent specified PC from surfing Internet for 5 minutes.  
2. The IP blocked by the router will be shown in red, and the session column will display the remaining time that the specified IP will be blocked.

**Enable Data Flow Monitor** Check this box to enable this function.

**Refresh Seconds** Use the drop down list to choose the time interval of refreshing data flow that will be done by the system automatically.

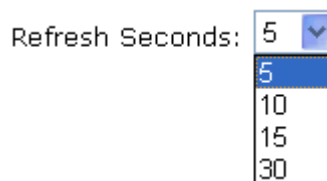

**Refresh** Click this link to refresh this page manually.

<b>Index</b>	Display the number of the data flow.
<b>IP Address</b>	Display the IP address of the monitored device.
<b>TX rate (kbps)</b>	Display the transmission speed of the monitored device.
<b>RX rate (kbps)</b>	Display the receiving speed of the monitored device.
<b>Sessions</b>	Display the session number that you specified in Limit Session web page.

**Action** **Block** - can prevent specified PC accessing into Internet within 5 minutes.

Page: 1 | Refresh

bps)	Sessions	Action
	1 / 100	<b>Block</b>

**Unblock** – the device with the IP address will be blocked in five minutes. The remaining time will be shown on the session column.

Page: 1 | Refresh

Sessions	Action
blocked / 299	<b>Unblock</b>

### 3.17.7 Traffic Graph

Click **Diagnostics** and click **Traffic Graph** to pen the web page. Choose WAN1 Bandwidth/WAN2 Bandwidth or Sessions for viewing different traffic graph. Click **Refresh** to renew the graph at any time.

Diagnostics >> Traffic Graph

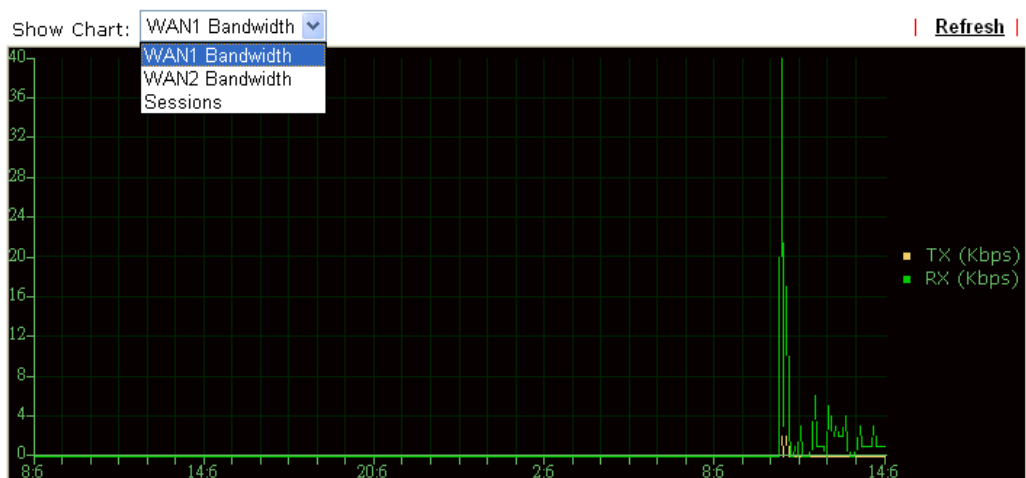

The horizontal axis represents time. Yet the vertical axis has different meanings. For WAN1/WAN2 Bandwidth chart, the numbers displayed on vertical axis represent the numbers of the transmitted and received packets in the past.

For Sessions chart, the numbers displayed on vertical axis represent the numbers of the NAT sessions during the past.

### 3.17.8 Ping Diagnosis

Click **Diagnostics** and click **Ping Diagnosis** to pen the web page.

Diagnostics >> Ping Diagnosis

**Ping Diagnosis**

**Note:** If you want to ping a LAN PC or you don't want to specify which WAN to ping through, please select "Unspecified".

Ping through:

Ping to:  IP Address:

**Result** [Clear](#)

#### Ping through

Use the drop down list to choose the WAN interface that you want to ping through or choose **Unspecified** to be determined by the router automatically.

Ping through:

- Unspecified
- WAN1
- WAN2

#### Ping to

Use the drop down list to choose the destination that you want to ping.

Ping to:

- Host / IP
- GateWay1
- GateWay2
- DNS

#### IP Address

Type in the IP address of the Host/IP that you want to ping.

#### Run

Click this button to start the ping work. The result will be displayed on the screen.

**Clear** Click this link to remove the result on the window.

### 3.17.9 Trace Route

Click **Diagnostics** and click **Trace Route** to open the web page. This page allows you to trace the routes from router to the host. Simply type the IP address of the host in the box and click **Run**. The result of route trace will be shown on the screen.

Diagnostics >> Trace Route

#### Trace Route

Trace through: Unspecified ▼  
Protocol: ICMP ▼  
Host / IP Address:  Run  
Result | Clear |

#### Trace through

Use the drop down list to choose the WAN interface that you want to ping through or choose **Unspecified** to be determined by the router automatically.

Trace through:  ▼  
Unspecified  
WAN1  
WAN2

#### Protocol

Use the drop down list to choose suitable protocol.

ICMP ▼  
ICMP  
UDP

#### Host/IP Address

It indicates the IP address of the host.

#### Run

Click this button to start route tracing work.

#### Clear

Click this link to remove the result on the window.



# 4

## Registration for the Router

To use the anti-intrusion, anti-virus and anti-spam features of VigorPro series router, you have to create a new account, finish the registration for that account by using the router and complete the registration for the Vigor router. After finishing the registration of the router, you can download the newly update types and rules of anti-intrusion and anti-virus during the valid time of the license key you purchased.

There are two ways to create and activate new account. One is created by accessing [www.vigorpro.com](http://www.vigorpro.com) (refer to section 4.1), the other is from router's web configurator (refer to section 4.2).

After activating the new account, you have to register your router from router's web configurator (refer to section 4.3). Follow the steps listed below to finish the registration and activation.

### 4.1 Creating and Activating an Account from VigorPro Website

To activate anti-virus/anti-intrusion function, you need to register an account on [www.vigorpro.com](http://www.vigorpro.com) firstly. Please follow the steps below to create a new account.

1. Open your browser with URL: [www.vigorpro.com](http://www.vigorpro.com). Find the line of **Not registered yet?**. Then, click the link **Click here!** to access into next page.

The screenshot shows the VigorPro website interface. On the left is a red navigation menu with links: Home, About Us, Product, My Information, Security Information, Downloads, Technical Support, Submit Virus Sample, and Close. The main content area features a 'Unified Security Firewall' advertisement with a woman working on a laptop. Below this is a 'SECURITY INFORMATION' section with a list of virus and attack alerts, each with a severity bar (low to high) and a 'More' link. A red box highlights the text 'Not registered yet? Click here!' in the right sidebar. The sidebar also contains a 'LOGIN' form with fields for Username, Password, and AuthCode, a 'Login' button, and a 'Contact DrayTek' link. At the bottom of the sidebar is a 'SECURITY NEWS' section with several news items dated Nov 16, 2006.

2. Check to confirm that you accept the Agreement and click **Accept**.

**Register** Search for this site

---

**Create an account - Please enter personal profile.**

- 1 Agreement
- 2 Personal Information
- 3 Preferences
- 4 Completion

===== VigorPro Agreement =====

1. Agreement  
 Draytek provides VigoPro(www.vigorpro.com) service according to this agreement. When you use vigorpro service, it means that you have read, understand and agree to accept the items listed in this agreement. Draytek can modify or change the content of the items without any reasons. It is suggested for you to notice the medications or changes at any time. If you still use vigorpro service after knowing the modifications and changes of this service, it means you have read, understand and agree to accept the modifications and changes. If you do not agree the content of this agreement, please stop using vigorpro service.

2. Registration  
 To use this service, you have to agree the following conditions:  
 (a) Provide your complete and correct information according to the registration steps of this service.  
 (b) If you provide any incorrect or fake information here, DrayTek has the right to pause or terminate

I have read and understand the above Agreement. (Use the scroll bar to view the entire agreement)

3. Type your personal information in this page and then click **Continue**.

**Register** Search for this site

---

**Create an account - Please enter personal profile.**

Fields marked by (\*) are required

- 1 Agreement
- 2 Personal Information
- 3 Preferences
- 4 Completion

**Account Information**

UserName :\*

( 3 ~ 20 characters )

Password :\*

( 4 ~ 20 characters : Do not set the same as the username.)

Confirm Password :\*

**Personal Information**

First Name :\*

Last Name :\*

Company Name :

Email Address :\*

Please note that a valid E-mail address is required to receive the Subscription Code. You will need this code to activate your account.

Tel :  -

Country :\*

Career :\*

4. Choose proper selection for your computer and click **Continue**.

The screenshot shows a registration page with a blue header containing the word "Register" and a search bar with a "GO" button. Below the header, the text "Create an account - Please enter personal profile." is displayed. On the left, there is a vertical list of four steps: 1 Agreement, 2 Personal Information, 3 Preferences (highlighted in blue), and 4 Completion. The main content area contains the following questions and answers:

- How did you find out about this website? Internet
- What kind of anti-virus do you use? ClamAV
- I would like to subscribe to the vigorpro e-letter.
- I would like to receive DrayTek product news.

At the bottom right, there are two buttons: "<< Back" and "Continue >>".

5. Now you have created an account successfully.

The screenshot shows the same registration page as above, but now the "4 Completion" step is highlighted in blue. A large red-bordered box with a white background is centered on the page. The box has a red header with the word "Completion" in white. The text inside the box reads:

A confirmation email has been sent to  
**carrie\_ni@draytek.com**  
Please click on the activation link in the email  
to activate your account

Below the text, the word "START" is written in large, bold, blue capital letters.

6. Check to see the confirmation email with the title of **New Account Confirmation Letter from www.vigorpro.com**.

\*\*\*\*\* This is an automated message from www.vigorpro.com.\*\*\*\*\*

Thank you ( **carrie** ) for creating an account.

Please click on the activation link below to activate your account

Link : [Activate my Account](#)

- Click the **Activate my Account** link to enable the account that you created. The following screen will be shown to verify the register process is finished. Please click **Login**.

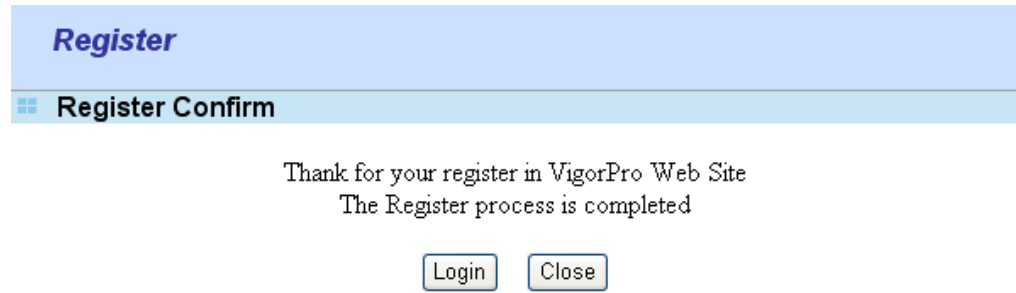

**Register**

**Register Confirm**

Thank for your register in VigorPro Web Site  
The Register process is completed

Login Close

- When you see the following page, please type in the account and password (that you just created) in the fields of **UserName** and **Password**. Then type the code in the box of **AuthCode** according to the value displayed on the right side of it.



**Relogin** Search for this site  GO

This service is available for VigorPro member only. Please login to access VigorPro.  
If you are not one of the members of VigorPro, please create an account first.

**LOGIN**

UserName :

Password :

Auth Code :  

If you cannot read the word, click here

Login

Don't have a VigorPro Account ?

[Create an account now](#)

If you are having difficulty logging in, contact our customer service.  
Customer Service : 886 3 597 2727 or  
email to :webmaster@draytek.com

- Now, click **Login**. Your account has been activated.

## 4.2 Creating and Activating an Account from Router Web Configurator

You, also can created and register a new account from the web configurator of the VigorPro router.

1. Open a web browser on your PC and type **http://192.168.1.1**. A pop-up window will open to ask for username and password. Do not type any word on the window and click **OK**.
2. From the router's web page, please open **Defense Configuration >>Activation**. You will see the following web page.

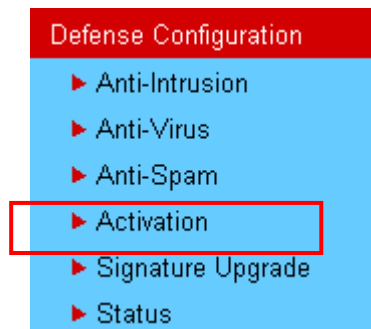

3. Click any one of the **Activate** link from the **Activation** web page.

Defense Configuration >> Activation

**Anti-Intrusion/Anti-Virus License**

[Status:Not Activated]

**Activate**

**Anti-Spam License**

[Status:Not Activated]

**Activate**

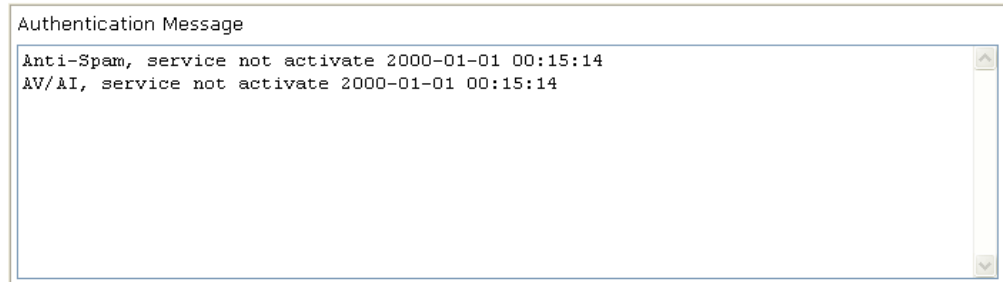

**Note:** If you want to use email alert or syslog, please configure the [SysLog/Mail Alert Setup](#) page.

4. A **Re-login** page will be shown on the screen.

Re-login Search for this site  GO

This service is available for VigorPro member only. Please login to access VigorPro.  
If you are not one of the members of VigorPro, please create an account first.

**LOGIN**

UserName :

Password :

Auth Code :  

If you cannot read the word, click here

Login

Don't have a VigorPro Account ?

[Create an account now](#)

If you are having difficulty logging in, contact our customer service.  
Customer Service : 886 3 597 2727 or  
email to :webmaster@draytek.com

5. Locate and click **Create an account now link** on the bottom of this page. You will access into the following page. Check the box below to confirm that you accept the Agreement and click **Accept**.

Register Search for this site  GO

Create an account - Please enter personal profile.

1 Agreement

2 Personal Information

3 Preferences

4 Completion

===== VigorPro Agreement =====

1. Agreement  
Draytek provides VigorPro(www.vigorpro.com) service according to this agreement. When you use vigorpro service, it means that you have read, understand and agree to accept the items listed in this agreement. Draytek can modify or change the content of the items without any reasons. It is suggested for you to notice the modifications or changes at any time. If you still use vigorpro service after knowing the modifications and changes of this service, it means you have read, understand and agree to accept the modifications and changes. If you do not agree the content of this agreement, please stop using vigorpro service.

2. Registration  
To use this service, you have to agree the following conditions:  
(a) Provide your complete and correct information according to the registration steps of this service.  
(b) If you provide any incorrect or fake information here, DrayTek has the right to pause or terminate your account.

I have read and understand the above Agreement. (Use the scroll bar to view the entire agreement)

<< Back Accept >>

6. Type your personal information in this page and then click **Continue**.

**Register** Search for this site

---

**Create an account - Please enter personal profile.**

Fields marked by (\*) are required

**1 Agreement**

**2 Personal Information**

**3 Preferences**

**4 Completion**

**Account Information**

UserName :\*    
(3 ~ 20 characters)

Password :\*   
(4 ~ 20 characters : Do not set the same as the username.)

Confirm Password :\*

**Personal Information**

First Name :\*

Last Name :\*

Company Name :

Email Address :\*   
Please note that a valid E-mail address is required to receive the Subscription Code. You will need this code to activate your account.

Tel :  -

Country :\*

Career :\*

7. Choose proper selection for your computer and click **Continue**.

**Register** Search for this site

---

**Create an account - Please enter personal profile.**

**1 Agreement**

**2 Personal Information**

**3 Preferences**

**4 Completion**

How did you find out about this website?

What kind of anti-virus do you use?

I would like to subscribe to the vigorpro e-letter.

I would like to receive DrayTek product news.

8. Now you have created an account successfully.

The screenshot shows a web page with a blue header containing the word "Register" and a search bar with a "GO" button. Below the header, the text "Create an account - Please enter personal profile." is displayed. On the left, there is a vertical list of four steps: 1 Agreement, 2 Personal Information, 3 Preferences, and 4 Completion. The "4 Completion" step is highlighted with a blue background. To the right of this list is a red-bordered box with a red header that says "Completion". Inside this box, the text reads: "A confirmation email has been sent to **carrie\_m@draytek.com**. Please click on the activation link in the email to activate your account." Below this text is a large, bold, blue "START" button.

9. Check to see the confirmation email with the title of **New Account Confirmation Letter from www.vigorpro.com.**

\*\*\*\*\* This is an automated message from www.vigorpro.com. \*\*\*\*\*

Thank you ( **carrie** ) for creating an account.

Please click on the activation link below to activate your account

Link : [Activate my Account](#)

10. Click the **Activate my Account** link to enable the account that you created. The following screen will be shown to verify the register process is finished. Please click **Login**.

The screenshot shows a light blue header with the word "Register" in bold. Below the header, the text "Register Confirm" is displayed. The main content area contains the text: "Thank for your register in VigorPro Web Site" and "The Register process is completed". At the bottom of the page, there are two buttons: "Login" and "Close".



11. When you see the following page, please type in the account and password (that you just created) in the fields of **UserName** and **Password**. Then type the code in the box of AuthCode according to the value displayed on the right side of it.

**Re-login** Search for this site

This service is available for VigorPro member only. Please login to access VigorPro.  
If you are not one of the members of VigorPro, please create an account first.

**LOGIN**

UserName :   
Password :   
Auth Code :  

If you cannot read the word, click here

Don't have a VigorPro Account ?

[Create an account now](#)

If you are having difficulty logging in, contact our customer service.  
Customer Service : 886 3 597 2727 or  
email to [webmaster@draytek.com](mailto:webmaster@draytek.com)

12. Now, click **Login**. Your account has been activated. And the following page will be shown automatically.

**My Product** Search for this site

**Device Registration**

**Welcome, carrie**  
**Last Login Time :** 2006-08-16 17:08:25  
**Last Login From :** 218.174.234.195  
**Current Login Time :** 2006-08-16 17:13:51  
**Current Login From :** 218.174.234.195

RowNo :   PageNo :



DrayTek will maintain a database of MAC address/serial number of shipped goods. Only products with shipping records can be registered. If your VigorPro 5300 cannot hook up to your account, please contact your reseller or DrayTek's technical support.

## 4.3 Registering Your Vigor Router

You have activated the new account for the router. Now, it is the time for you to register your vigor router. Open **Defense Configuration >>Activation**; the other is to register by using **Anti-Spam>>Profile Setting**. Registering Vigor router should be done just for once. **If the router has been registered previously, the system will not allow you to register the router again.** After finishing the router registration, you can activate Anti-Virus, Anti-Intrusion and Anti-Spam respectively.

1. Open a web browser on your PC and type **http://192.168.1.1**. A pop-up window will open to ask for username and password. Do not type any word on the window and click **OK**.
2. From the router's web page, please open **Defense Configuration >>Activation**. You will see the following web page.

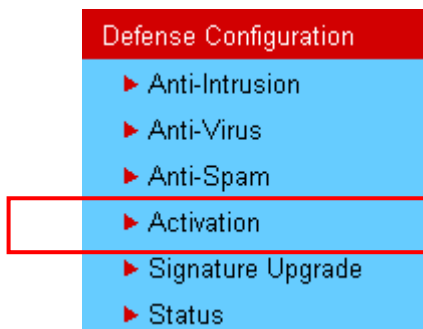

3. Click any one of the **Activate** link from the **Activation** web page.

Defense Configuration >> Activation

**Anti-Intrusion/Anti-Virus License**  
[Status:Not Activated]

**Activate**

**Anti-Spam License**  
[Status:Not Activated]

**Activate**

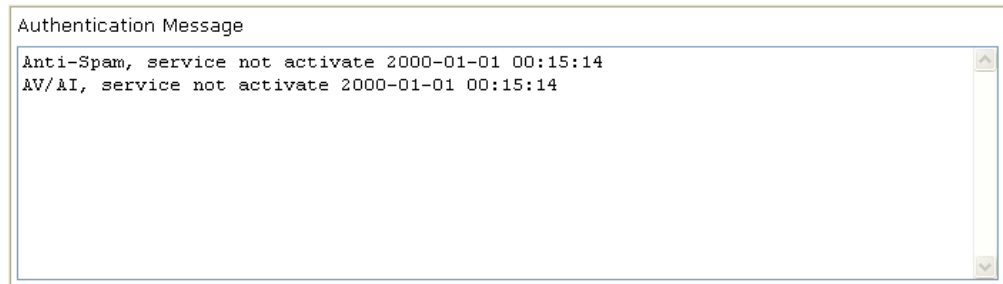

**Note:** If you want to use email alert or syslog, please configure the [SysLog/Mail Alert Setup](#) page.

4. A **Re-login** page will be shown on the screen. Please type the account and password that you created previously. And click **Login**.

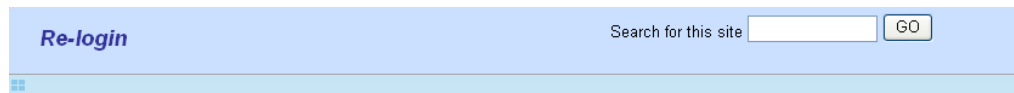

This service is available for VigorPro member only. Please login to access VigorPro.  
If you are not one of the members of VigorPro, please create an account first.



If you are having difficulty logging in, contact our customer service.  
Customer Service : 886 3 597 2727 or  
email to : [webmaster@draytek.com](mailto:webmaster@draytek.com)

5. The following page will be displayed after you logging in VigorPro server. From this page, please click **Add**.

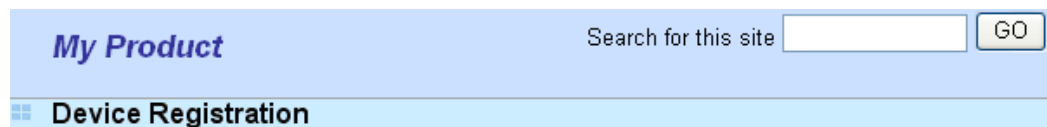

**Welcome, carrie**  
**Last Login Time** : 2006-08-16 17:08:25  
**Last Login From** : 218.174.234.195  
**Current Login Time** : 2006-08-16 17:13:51  
**Current Login From** : 218.174.234.195

RowNo : 1 PageNo : **Add**

6. When the following page appears, please type in Nick Name (for the router) and choose the right purchase date from the popup calendar (it appears when you click on the box of Purchase Date).

**My Product** Search for this site

**Device Add**

Serial number: 999999999990

Nick Name:

Purchase Date:

August 2006

Wk	Mon	Tue	Wed	Thu	Fri	Sat	Sun
31		1	2	3	4	5	6
32	7	8	9	10	11	12	13
33	14	15	16	17	18	19	20
34	21	22	23	24	25	26	27
35	28	29	30	31			

Today is Wed, 16 Aug 2006

7. After adding the basic information for the router, please click **Submit**.

**My Product** Search for this site

**Device Add**

Serial number: 999999999990

Nick Name:

Purchase Date:

8. Now, your router information has been added to the database. Click **OK** to leave this web page and return to **My Product** web page.

Your device has been successfully added to the database.

## 4.4 Activating Anti-Virus/Anti-Intrusion/Anti-Spam Service

After registering your vigor router, you have to follow the steps listed below to activate anti-virus/anti-intrusion/anti-spam service to obtain full security for your computer.

### 4.4.1 For Anti-Virus and Anti-Intrusion Service

1. Open a web browser on your PC and type **http://192.168.1.1**. A pop-up window will open to ask for username and password.
2. From the router's web page, please open **Defense Configuration >>Activate**. You will see the following web page.

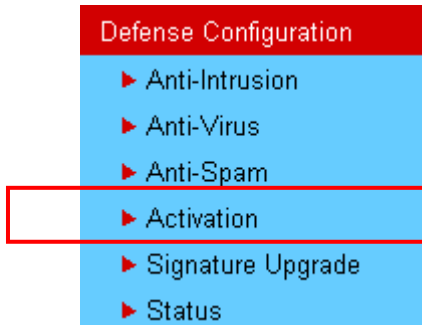

3. Click the **Activate** link from Anti-Intrusion/Anti-Virus License to activate Anti-Intrusion/Anti-Virus service.

Defense Configuration >> Activation

**Anti-Intrusion/Anti-Virus License**  
[Status:Not Activated]

[Activate](#)

**Anti-Spam License**  
[Status:Not Activated]

[Activate](#)

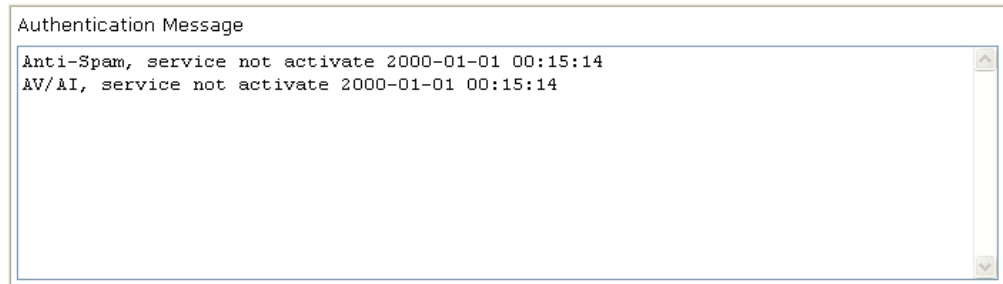

**Note:** If you want to use email alert or syslog, please configure the [SysLog/Mail Alert Setup](#) page.

- A **Re-login** page will be shown on the screen. Please type the account and password that you created previously. And click **Login**.

**Re-login** Search for this site

This service is available for VigorPro member only. Please login to access VigorPro.  
If you are not one of the members of VigorPro, please create an account first.

**LOGIN**

UserName :

Password :

Auth Code :  

If you cannot read the word, click here

**Don't have a VigorPro Account ?**

[Create an account now](#)

If you are having difficulty logging in, contact our customer service.  
Customer Service : 886 3 697 2727 or  
email to : [webmaster@dravtek.com](mailto:webmaster@dravtek.com)

- On the web page of **My Product**, you can find a list of the devices that you add with the above steps. Currently, you just have added VigorPro 5300. Please click the serial number link.

**My Product** Search for this site

**Device Registration**

**Welcome, carrie**  
**Last Login Time** : 2006-08-16 17:08:25  
**Last Login From** : 218.174.234.195  
**Current Login Time** : 2006-08-16 17:13:51  
**Current Login From** : 218.174.234.195

RowNo :  PageNo :

**Your Devices**

Serial Number	Device Name	Model	Note
9999999999990	carrie	VigorPro 5300	-

- From the **Device's Service** section, click the **Activate** button for AI-AV (Anti-Intrusion & Anti-Virus) service.

**My Product** Search for this site

---

**Device Information**

Nick Name : [carrie](#)

Serial : [999999999990](#)

Model : [VigorPro 5300](#)

---

**Device's Service**

Service	Action	Status	Start Date	Expired Date	Provider
AI-AV	<input type="button" value="Activate"/> <input type="button" value="Apply"/>	-	-	-	-
AS	<input type="button" value="Activate"/> <input type="button" value="Apply"/>	-	-	-	-

**Action**

**Activate :** It allows the user to activate the service provider (DT-DT and DT-KL) dedicated to the router. If the record of the license key exists, the button "Upgrade" will show up instead.

**Apply :** It allows the user to adopt the selected service provider on the router. It also enables the user to switch one key to the other.

- Rename** It allows you to change the account name.
- Delete** It allows you to delete account name used currently.
- Transfer** It allows you to transfer the VigorPro device together with applied license to someone who has already registered another account in [www.vigorpro.com](http://www.vigorpro.com). Be sure to press this button to transfer the product to whom you want to give. Otherwise he/she might not be able to maintain the license hooked up to the VigorPro device.
- Back** It allows you to return to the previous account.

7. In the following page, check the box of “**I have read and accept the above Agreement**”. The system will find out the date for you to activate this version of service. Then, click **Next**.

**My Product** Search for this site

**Confirm Message**

User Name : [carrie](#)  
 Serial : [200709210001](#)  
 Model : [VigorPro5510](#)

License Number	Service Provider	Status
DrayTek VigorPro Series End-User License Agreement IMPORTANT: DrayTek IS WILLING TO LICENSE THE ENCLOSED SOFTWARE TO YOU ONLY <input checked="" type="checkbox"/> I have read and accept the above Agreement. (Please check this box).		

**Note:** DT-DT means you can acquire the anti-intrusion and anti-virus services from DrayTek Corporation.

8. When this page appears, click **Register**.

**My Product** Search for this site

**Apply For A License Number**

Service Name: **AI-AV**

**STEP 2**

Enable It!! Enable the **VigorPro Statistical Reporting**

Activation Date (MM-DD-YYYY):

9. Next, the DrayTek Service Activation screen will be shown as the following:

**DrayTek Service Activation**

Service Name	Start Date	Expire Date	Status
Anti-Virus	2006-08-16	2006-09-15	DT-DT
Anti-Spam	---	---	Not Activated

Please check if the license fits with the service provider of your signature. To ensure normal operation for your router, update your signature again is recommended.

**Copyright © DrayTek Corp. All Rights Reserved.**

(Above figure supposes you have not activated Anti-Spam yet.)



- Click **Close**.
- Open **Defense Configuration>>Status** page of the router's web configurator. The start date and expire date for the license are shown in this page.

Defense Configuration >> Activation

---

**Anti-Intrusion/Anti-Virus License** [Activate](#)  
 [Status:DT-DT] [Start Date:2007-09-26 Expire Date:2010-09-26]

**Anti-Spam License** [Activate](#)  
 [Status:Not Activated]

Authentication Message

```
Anti-Spam, service not activate 2000-01-01 19:00:34
AV/AI, Get new license successful, 2007-09-26 01:51:56
```

**Note:** If you want to use email alert or syslog, please configure the [SysLog/Mail Alert Setup](#) page.

- Click **Activate** to access into VigorPro website again. Open the following page. You will see the AI-AV (with provider DT-DT) has been activated and in use.

**My Product** Search for this site

---

**Device Information**

Nickname : 5510  
 Serial : 200709210001  
 Model : VigorPro5510

---

**Device's Service**

Service	Provider	Action	Status	Start Date	Expired Date
AI-AV	DT-KL	<input type="button" value="Activate"/>	<span style="color: gray;">●</span> On	-	-
AI-AV	DT-DT	<input type="button" value="Renew"/>	<span style="color: green;">●</span> On	2007-09-26	2010-09-26
AS	CTCH	<input type="button" value="Trial"/>	<span style="color: gray;">●</span> On	-	-

<ul style="list-style-type: none"> <li><span style="color: green;">●</span> Means such service is in use.</li> <li><span style="color: red;">●</span> Means such service is not in use.</li> <li><span style="color: gray;">●</span> Means such service has not been activated yet.</li> <li><span style="color: yellow;">●</span> Means such service is in use and will be invalid soon(less than one month).</li> </ul>	<table border="0" style="width: 100%;"> <tr> <td style="border: 1px solid #ccc; padding: 2px;"><b>Trial</b></td> <td>Allows you to have the free trial for service.</td> </tr> <tr> <td style="border: 1px solid #ccc; padding: 2px;"><b>Renew</b></td> <td>Allows you to renew service license.</td> </tr> <tr> <td style="border: 1px solid #ccc; padding: 2px;"><b>Activate</b></td> <td>Allows you to activate service.</td> </tr> </table>	<b>Trial</b>	Allows you to have the free trial for service.	<b>Renew</b>	Allows you to renew service license.	<b>Activate</b>	Allows you to activate service.
<b>Trial</b>	Allows you to have the free trial for service.						
<b>Renew</b>	Allows you to renew service license.						
<b>Activate</b>	Allows you to activate service.						

Now, you have finished all the procedure for registering your router.

## 4.4.2 For Anti-Spam Service

Please follow the steps below to activate Anti-Spam Service for your system.

### Getting 30 Days of Free Charge

1. Open a web browser on your PC and type **http://192.168.1.1**. A pop-up window will open to ask for username and password.
2. From the router's web page, please open **Defense Configuration >>Activate**. You will see the following web page.

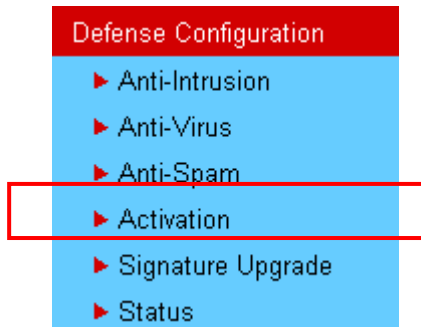

3. Click the **Activate** link from Anti-Spam License to activate Anti-Spam service.

Defense Configuration >> Activation

Anti-Intrusion/Anti-Virus License  
[Status:Not Activated]

[Activate](#)

Anti-Spam License  
[Status:Not Activated]

[Activate](#)

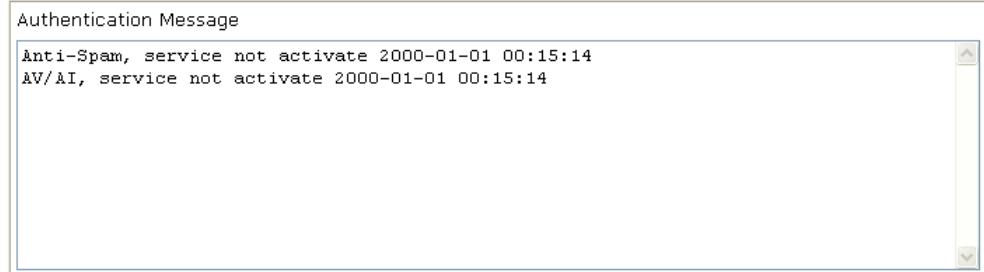

**Note:** If you want to use email alert or syslog, please configure the [SysLog/Mail Alert Setup](#) page.

- A **Re-login** page will be shown on the screen. Please type the account and password that you created previously. And click **Login**.

**Re-login** Search for this site

---

This service is available for VigorPro member only. Please login to access VigorPro.  
If you are not one of the members of VigorPro, please create an account first.

**LOGIN**

UserName :

Password :

Auth Code :  

If you cannot read the word, click here

Don't have a VigorPro Account ?

[Create an account now](#)

If you are having difficulty logging in, contact our customer service.  
Customer Service : 886 3 597 2727 or  
email to [webmaster@dravtek.com](mailto:webmaster@dravtek.com)

- On the web page of **My Product**, you can find a list of the devices that you add with the above steps. Currently, you just have added VigorPro 5300. Please click the serial number link.

**My Product** Search for this site

---

**Device Registration**

**Welcome, carrie**

**Last Login Time :** 2006-08-16 17:08:25  
**Last Login From :** 218.174.234.195  
**Current Login Time :** 2006-08-16 17:13:51  
**Current Login From :** 218.174.234.195

RowNo :  PageNo :

---

**Your Devices**

Serial Number	Device Name	Model	Note
<a href="#">999999999999</a>	carrie	VigorPro 5300	-



- From the **Device's Service** section, click the **Trial** button for AS (Anti-Spam) service.





**My Product** Search for this site

**Device Information**

Nickname : 5510  
 Serial : 200709210001  
 Model : VigorPro5510

**Device's Service**

Service	Provider	Action	Status	Start Date	Expired Date
AI-AV	DT-KL	<input type="button" value="Activate"/>	 On	-	-
AI-AV	DT-DT	<input type="button" value="Renew"/>	 On	2007-09-26	2010-09-26
AS	CTCH	<input type="button" value="Trial"/>	 On	-	-

 Green light means such service is in use.  
 Red light means such service is not in use.  
 Gray light means such service has not been activated yet.  
 Yellow light means such service is in use and will be invalid soon(less than one month).

Allows you to have the free trial for service.  
 Allows you to renew service license.  
 Allows you to activate service.

- In this page, check the box of **"I have read and accept the above Agreement"**. The system will find out the date for you to activate this version of service. Then, click **Next**.

**My Product** Search for this site

**Confirm Message**

User Name : carrie  
 Serial : 200709210001  
 Model : VigorPro5510

License Number	Service Provider	Status
End User License Agreement for Anti-Spam service on VigorPro router Ver 1.0		
<input checked="" type="checkbox"/> I have read and accept the above Agreement. (Please check this box).		

**Note:** CTCH means you can acquire anti-spam service from Commtouch.

- When this page appears, click **Register**.

**My Product** Search for this site

**Apply For A License Number**

Service Name: **AS**

**STEP 2**

Activation Date (MM-DD-YYYY):

9. Next, the DrayTek Service Activation screen will be shown as the following.

**DrayTek Service Activation**

---

Service Name	Start Date	Expire Date	Status
Anti-Virus	2007-09-26	2010-09-26	DT-DT
Anti-Spam	2007-09-26	2007-10-26	CTCH

Please check if the license fits with the service provider of your signature. To ensure normal operation for your router, update your signature again is recommended.

Copyright © DrayTek Corp. All Rights Reserved.

10. Click **Close**.

Now, you have finished all the procedure for activating Anti-Spam service for your router.

**Note:** You are allowed to use this version (with anti-spam feature) for 30 days after registration for your router. In addition, you will be informed with an e-mail before expire date of this version.

### Upgrade License for Anti-Spam

When thirty days for free of charge expires, you can apply for a new license by following the steps below:

1. Open a web browser on your PC and type **http://192.168.1.1**. A pop-up window will open to ask for username and password.
2. From the router's web page, please open **Defense Configuration >>Activate**. You will see the following web page.

Defense Configuration

- ▶ Anti-Intrusion
- ▶ Anti-Virus
- ▶ Anti-Spam
- ▶ Activation
- ▶ Signature Upgrade
- ▶ Status

3. Click the **Activate** link from Anti-Spam License to activate Anti-Spam service.

Defense Configuration >> Activation

**Anti-Intrusion/Anti-Virus License**

[Activate](#)

[Status:DT-DT] [Start Date:2007-09-26 Expire Date:2010-09-26]

**Anti-Spam License**

[Activate](#)

[Status:CTCH] [Start Date:2007-09-26 Expire Date:2007-10-26]

Authentication Message

**Note:** If you want to use email alert or syslog, please configure the [SysLog/Mail Alert Setup](#) page.

4. A **Re-login** page will be shown on the screen. Please type the account and password that you created previously. And click **Login**.

Re-login Search for this site

This service is available for VigorPro member only. Please login to access VigorPro.  
If you are not one of the members of VigorPro, please create an account first.

**LOGIN**

UserName :

Password :

Auth Code :  *thmj*

If you cannot read the word, [click here](#)

**Don't have a VigorPro Account ?**

[Create an account now](#)

If you are having difficulty logging in, contact our customer service.  
Customer Service : 988 3 597 2727 or  
email to [webmaster@draytek.com](mailto:webmaster@draytek.com)

5. On the web page of **My Product**, you can find a list of the devices that you add with the above steps. Currently, you just have added VigorPro 5300. Please click the serial number link.

**My Product** Search for this site

Device Registration

Welcome, **carrie**  
 Last Login Time : 2006-08-16 17:08:25  
 Last Login From : 218.174.234.195  
 Current Login Time : 2006-08-16 17:13:51  
 Current Login From : 218.174.234.195

RowNo :  PageNo :

Your Devices

Serial Number	Device Name	Model	Note
<a href="#">999999999999</a>	carrie	VigorPro 5300	-



6. From the **Device's Service** section, click the **Upgrade** buttons for AS (Anti-Spam) service.





**My Product** Search for this site

Device Information

Nickname : 5510  
 Serial : 200709210001  
 Model : VigorPro5510

Device's Service

Service	Provider	Action	Status	Start Date	Expired Date
AI-AV	DT-KL	<input type="button" value="Activate"/>	 On	-	-
AI-AV	DT-DT	<input type="button" value="Renew"/>	 On	2007-09-26	2010-09-26
AS	CTCH	<input type="button" value="Renew"/>	 On	2007-09-26	2007-10-26

 Green light means such service is in use.  
 Red light means such service is not in use.  
 Gray light means such service has not been activated yet.  
 Yellow light means such service is in use and will be invalid soon(less than one month).

Allows you to have the free trial for service.  
 Allows you to renew service license.  
 Allows you to activate service.

- In this page, type the License Number stated on the Anti-Spam license card in the field of **License Number**. Then, click **Add License**.

**My Product** Search for this site

**Apply For A License Number**

Service Name: **AS**  
 Service Provider: **CTCH**

**STEP 1**

License Number :

**Tip :** Please ensure that the licence key you enter is for the correct (your preferred) service provider.

- Now, the license number will be displayed on the page immediately. Click **Next**.

**My Product** Search for this site

**Apply For A License Number**

Service Name: **AS**  
 Service Provider: **CTCH**

**STEP 1**

License Number :

**Tip :** Please ensure that the licence key you enter is for the correct (your preferred) service provider.

Flag	License	Provider	Status
<input type="button" value="del"/>	E099E-A3733-ED2F3-DAC37	CTCH	valid



- In this page, check the box of “**I have read and accept the above Agreement**”. The system will find out the date for you to activate this version of service. Then, click **Next**.

**My Product** Search for this site

**Confirm Message**

User Name : carrie  
 Serial : 200705011001  
 Model : VigorPro5510

License Number	Service Provider	Status
E099E-A3733-ED2F3-DAC37	CTCH	valid

End User License Agreement  
 for Anti-Spam service on VigorPro router  
 Ver 1.0

I have read and accept the above Agreement. (Please check this box.)

- When this page appears, click **Apply**.

**My Product** Search for this site

**Apply For A License Number**

Service Name: AS  
**STEP 2**

Activation Date (MM-DD-YYYY):

(Above figure supposes you have not activated Anti-Virus yet.)

- Confirm Message window will appear for you to make a confirmation. Click **Confirm**.

Powered by **DrayTek** Search for this site

**Confirm Message**

User Name : carrie  
 Serial Number : 200705011001  
 Activate Date : 2007-10-26  
 Expired Date : 2008-10-26

License Number	Service Provider	Status
E099E-A3733-ED2F3-DAC37	CTCH	valid

- Next, the DrayTek Service Activation screen will be shown as the following.

### DrayTek Service Activation

---

Service Name	Start Date	Expire Date	Status
Anti-Virus	2007-09-26	2010-09-26	DT-DT
Anti-Spam	2007-10-26	2008-10-26	CTCH

Please check if the license fits with the service provider of your signature. To ensure normal operation for your router, update your signature again is recommended.

Copyright © DrayTek Corp. All Rights Reserved.

Close

13. Click **Close** to exit.

## 4.5 Applying a New License for Anti-Intrusion/Anti-Virus

When days for free of charge expires, you can apply for a new license by following the steps below:

1. Open a web browser on your PC and type **http://192.168.1.1**. A pop-up window will open to ask for username and password. Do not type any word on the window and click **OK**.
2. From the router's web page, please open **Defense Configuration >>Activation**. You will see the following web page

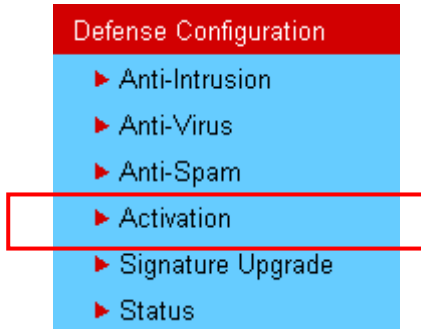

3. Click the **Activate** link from Anti-Intrusion/Anti-Virus License to activate Anti-Spam service.

Defense Configuration >> Activation

**Anti-Intrusion/Anti-Virus License**

[Status:Not Activated]

[Activate](#)

**Anti-Spam License**

[Status:Not Activated]

[Activate](#)

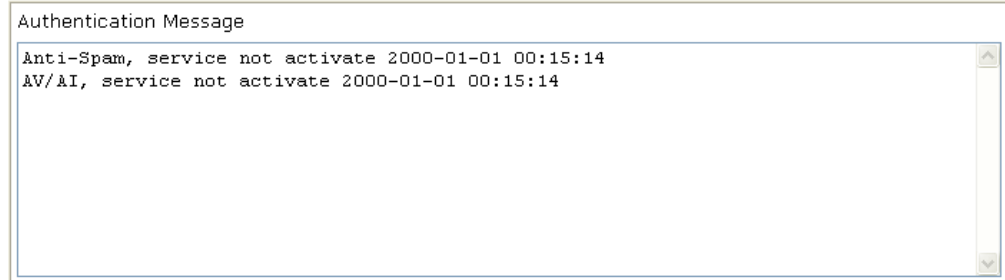

**Note:** If you want to use email alert or syslog, please configure the [SysLog/Mail Alert Setup](#) page.

- A **Re-login** page will be shown on the screen. Please type the account and password that you created previously. And click **Login**.

**Re-login** Search for this site

---

**This service is available for VigorPro member only. Please login to access VigorPro.  
If you are not one of the members of VigorPro, please create an account first.**

**LOGIN**

UserName :

Password :

Auth Code :  

If you cannot read the word, click here

**Don't have a VigorPro Account ?**

[Create an account now](#)

If you are having difficulty logging in, contact our customer service.  
Customer Service : 886 3 597 2727 or  
email to : [webmaster@draytek.com](mailto:webmaster@draytek.com)

- On the web page of **My Product**, you can find a list of the devices that you add with the above steps. Currently, you just have added VigorPro 5300. Please click the serial number link.

**My Product** Search for this site

---

**Welcome, carrie**  
**Last Login Time :** 2007-09-21 15:56:36  
**Last Login From :** 220.135.242.48  
**Current Login Time :** 2007-09-21 16:59:27  
**Current Login From :** 220.135.242.48

RowNo :  PageNo :

---

**Your Device List**

Serial Number	Device Name	Model	Note
<a href="#">200709210001</a>	5300	VigorPro5300	-

- From the **Device's Service** section, click the **Renew** button for AI-AV (Anti-Intrusion & Anti-Virus) service (service provider is DT-DT).

**My Product** Search for this site

**Device Information**

Nickname : 5300  
 Serial : 200709210001  
 Model : VigorPro5300

**Device's Service**

Service	Provider	Action	Status	Start Date	Expired Date
AI-AV	DT-KL	<input type="button" value="Activate"/>	On	-	-
AI-AV	DT-DT	<input type="button" value="Renew"/>	On	2007-09-26	2010-09-26
AS	CTCH	<input type="button" value="Trial"/>	On	-	-

Means such service is in use.  
 Means such service is not in use.  
 Means such service has not been activated yet.  
 Means such service is in use and will be invalid soon(less than one month).

Allows you to have the free trial for service.  
 Allows you to renew service license.  
 Allows you to activate service.

- In the following page, please type in license number shown on the License Key card. Enter the number and click **Add License**.

**My Product** Search for this site

**Apply For A License Number**

Service Name: AI-AV  
 Service Provider: DT-KL

**STEP 1**

License Number :

**Tip :** Please ensure that the licence key you enter is for the correct (your preferred) service provider.

**Note:** DT-KL allows you to acquire the anti-intrusion service from DrayTek and anti-virus service from Kaspersky. DT-DT allows you to acquire the anti-intrusion and anti-virus services from DrayTek Corporation.

- After typing the license key, click **Add License**. The basic information for the one you selected will be shown on the following page. Click **Next**.

**My Product** Search for this site

**Apply For A License Number**

Service Name: **AI-AV**  
 Service Provider: **DT-KL**

**STEP 1**

License Number :

**Tip :** Please ensure that the licence key you enter is for the correct (your preferred) service provider.

Flag	License	Provider	Status
<input type="button" value="del"/>	DA2D0-C443A-XXXXX-XXXXX	DT-KL	valid

9. Check the box of “**I have read and accept the above Agreement**” and click **Next**.

**My Product** Search for this site

**Confirm Message**

User Name : **carrie**  
 Serial : **200705011001**  
 Model : **VigorPro5300**

License Number	Service Provider	Status
DA2D0-C443A-XXXXX-XXXXX	DT-KL	valid

End User License Agreement  
 Ver 1.0

I have read and accept the above Agreement. (Please check this box).

10. When this page appears, click **Apply**.

**My Product** Search for this site

**Apply For A License Number**

Service Name: **AI-AV**

**STEP 2**

Activation Date (MM-DD-YYYY):

11. Confirm Message window will appear for you to make a confirmation. Click **Confirm**.

Powered by **DrayTek** Search for this site

---

**Confirm Message**

User Name :     carrie  
Serial Number : 200705011001  
Activate Date : 2007-10-26  
Expired Date : 2008-10-26

License Number	Service Provider	Status
DA2D0-C443A-XXXX-XXXX	DT-KL	valid

12. The Service Activation screen will be shown as the following.

**DrayTek Service Activation**

---

Service Name	Start Date	Expire Date	Status
Anti-Virus	2007-10-26	2008-10-26	DT-KL

Please check if the license fits with the service provider of your signature. To ensure normal operation for your router, update your signature again is recommended.

Copyright © DrayTek Corp. All Rights Reserved.

13. Click **Close**.

Return to **Defense Configuration>>Status** page of the router's web configurator. The start date and expire date for the license will be shown in this page.

## 4.6 Backup and Upgrade Signature for Anti-Intrusion/Anti-Virus

You can get the most updated signature from DrayTek's server if the license key of anti-virus/anti-intrusion for the VigorPro 5300 is not expired. Before you upgrade the signature, please check the validation information either from WEB user interface of VigorPro 5300 or account information from [www.vigorpro.com](http://www.vigorpro.com).

1. Open a web browser on your PC and type **http://192.168.1.1**. A pop-up window will open to ask for username and password. Do not type any word on the window and click **OK**.
2. From the router's web page, please open **Defense Configuration >>Signature Upgrade**. You will see the following web page.

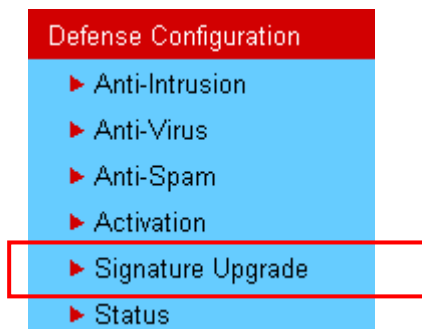

3. On Signature Upgrade web page, locate Backup and Download Now!!!.

Defense Configuration >> Signature Upgrade

---

**Signature Upgrade Setting**  
Signature Version : **basic**  
Signature Build Date : **Tue Aug 29 09:16:25.00 2006**

<b>Setup download server</b>	auto-selected	<a href="#">find more</a>
<b>Setup query server</b>	auto-selected	<a href="#">find more</a>

Signature authentication/download message:

**Upgrade Manually**

<input type="button" value="Import"/>	<input type="button" value="Backup"/>	<input type="button" value="Download Now !!!"/>
---------------------------------------	---------------------------------------	---

**Upgrade Automatically**

Scheduled Update

<input checked="" type="radio"/> Every:	1 (hour)	00 (minutes after the hour)
<input type="radio"/> Daily:	0 (hour)	00 (minute)
<input type="radio"/> Weekly:	Sunday (day)	0 (hour) 00 (minute)

### Time for Backup

Before changing other license, it is suggested for you to backup the original signature first. To backup current signature with the filename **vigorpro.sig**, click **Backup**.



## Time for Download

After changing other license, it is suggested for you to download newly update signature for your router. To download newly update anti-intrusion and anti-virus from VigorPro website, please click **Download Now!!!**.

## Time for Import

Backup files can be imported whenever you want. To use a saved signature information, please click **Import**.

In addition, users can specify certain time for executing the upgrade automatically by the router. Remember to check the **Schedule Update** box and click **OK** to activate the time settings.

## 4.7 Switching between DT-DT and DT-KL

You can change anti-virus and anti-intrusion service between DT-DT and DT-KL service provider whenever you want. Simply follow the steps below:

1. Open a web browser on your PC and type **http://192.168.1.1**. A pop-up window will open to ask for username and password. Do not type any word on the window and click **OK**.
2. From the router's web page, please open **Defense Configuration >>Activate**. You will see the following web page.

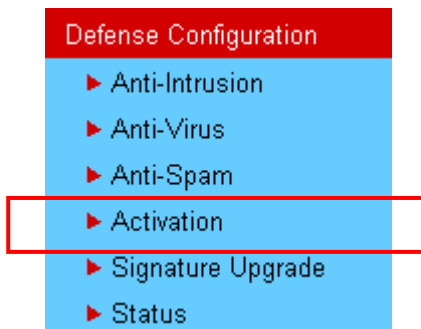

3. Click the **Activate** link from the **Defense Configuration >>Activate** web page. Remember that the license currently selected is DT-DT. Therefore, you can switch into DT-KL if you want.

Defense Configuration >> Activation

### Anti-Intrusion/Anti-Virus License

[Status:DT-DT] [Start Date:2006-07-27 Expire Date:2009-07-27]

**Activate**

### Anti-Spam License

[Status:Not Activated]

**Activate**

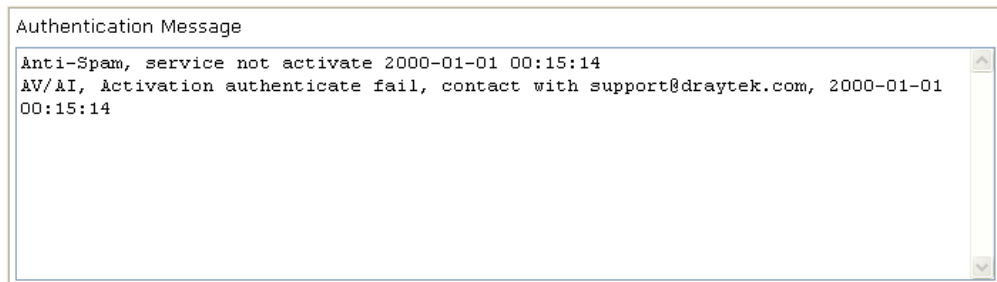

**Note:** If you want to use email alert or syslog, please configure the **SysLog/Mail Alert Setup** page.

4. A **Re-login** page will be shown on the screen. Please type new account and password that you created previously. And click **Login**.

**Re-login** Search for this site

**This service is available for VigorPro member only. Please login to access VigorPro.  
If you are not one of the members of VigorPro, please create an account first.**

**LOGIN**

UserName :

Password :

Auth Code :  

If you cannot read the word, click here

---

**Don't have a VigorPro Account ?**

[Create an account now](#)

If you are having difficulty logging in, contact our customer service.  
Customer Service : 886 3 597 2727 or  
email to : [webmaster@draytek.com](mailto:webmaster@draytek.com)

5. The following page will be shown automatically. You will find there are two devices service added to your router. If you activated only one service before, it must be only one service displayed here. In this case, DT-DT and DT-KL services are registered on the VigorPro website. However, DT-DT service is installed into the router at present.

**My Product** Search for this site

---

**Device Information**

**Nickname :** 5510

**Serial :** 200709210001

**Model :** VigorPro5510

---

**Device's Service**

Service	Provider	Action	Status	Start Date	Expired Date
AI-AV	DT-KL	<input type="button" value="Renew"/>	<span style="color: red;">●</span> On	2007-10-26	2008-10-26
AI-AV	DT-DT	<input type="button" value="Renew"/>	<span style="color: green;">●</span> On	2007-09-26	2010-09-26
AS	CTCH	<input type="button" value="Trial"/>	<span style="color: gray;">●</span> On	-	-

● Means such service is in use.  
● Means such service is not in use.  
● Means such service has not been activated yet.  
● Means such service is in use and will be invalid soon (less than one month).

Allows you to have the free trial for service.  
 Allows you to renew service license.  
 Allows you to activate service.

6. Click the **On** button on the line with DT-KL service to use that service. Then, the Status light for DT-DT service will be changed into red which means you can press on the **On** button for that one to use it for next time.
7. Now, you have successfully switched the service provider for your router.

## 4.8 Enabling Anti-Virus/Anti-Intrusion/Anti-Spam

After applying an account, registering your account and router, you have to access into the web page of Vigor router to enable Anti-Virus/Anti-Intrusion functions. There are two ways to enable it.

- A. For the default rule of firewall, please open **Firewall>>General Setup** page. Check the box of **Enable** for Anti-Intrusion and choose proper action (profile) from the drop down list of Anti-Virus and Anti-Spam. Next, click **OK** to finish the procedure of activation.

Firewall >> General Setup

**General Setup**

<b>Call Filter</b>	<input checked="" type="radio"/> Enable <input type="radio"/> Disable	Start Filter Set <span style="border: 1px solid #ccc; padding: 2px;">Set#1</span> ▼
<b>Data Filter</b>	<input checked="" type="radio"/> Enable <input type="radio"/> Disable	Start Filter Set <span style="border: 1px solid #ccc; padding: 2px;">Set#2</span> ▼

---

**Actions for default rule:**

Application	Action/Profile	Syslog
<b>Filter</b>	<span style="border: 1px solid #ccc; padding: 2px;">Pass</span> ▼	<input type="checkbox"/>
<b>IM/P2P Filter</b>	<span style="border: 1px solid #ccc; padding: 2px;">None</span> ▼	<input type="checkbox"/>
<b>URL Content Filter</b>	<span style="border: 1px solid #ccc; padding: 2px;">None</span> ▼	<input type="checkbox"/>
<b>Web Content Filter</b>	<span style="border: 1px solid #ccc; padding: 2px;">None</span> ▼	<input type="checkbox"/>
<b>Anti-Virus</b>	<span style="border: 1px solid #ccc; padding: 2px;">None</span> ▼	<input type="checkbox"/>
<b>Anti-Intrusion</b>	<input type="checkbox"/> Enable	<input type="checkbox"/>
<b>Anti-Spam</b>	<span style="border: 1px solid #ccc; padding: 2px;">None</span> ▼	<input type="checkbox"/>

---

Advance Setting Edit

---

Apply IP filter to VPN incoming packets

- B. For specified filter rule (there are twelve filter sets in Firewall, and each set is allowed to set seven filter rules), please check the box of **Enable** for Anti-Intrusion and choose proper action (profile) from the drop down list of Anti-Virus. Next, click **OK** to finish the procedure of activation.

Filter Set 1 Rule 1

<input checked="" type="checkbox"/> Check to enable the Filter Rule		
Comments:	Block NetBios	
Index(1-15) in <b>Schedule</b> Setup:	, , ,	
<hr/>		
Direction:	LAN -> WAN	
Source IP:	Any	<input type="button" value="Edit"/>
Destination IP:	Any	<input type="button" value="Edit"/>
Service Type:	TCP/UDP, Port: from 137~139 to undefined	<input type="button" value="Edit"/>
Fragments:	Don't Care	
<hr/>		
<b>Application</b>	<b>Action/Profile</b>	<b>Syslog</b>
Filter:	Pass If No Further Match	<input type="checkbox"/>
Branch to Other Filter Set:	None	
<b>IM/P2P Filter:</b>	None	<input type="checkbox"/>
<b>URL Content Filter</b>	None	<input type="checkbox"/>
<b>Web Content Filter</b>	None	<input type="checkbox"/>
<b>Anti-Virus:</b>	None	<input type="checkbox"/>
<b>Anti-Intrusion:</b>	<input type="checkbox"/> Enable	<input type="checkbox"/>
<b>Anti-Spam:</b>	None	<input type="checkbox"/>
<hr/>		
Advance Setting	<input type="button" value="Edit"/>	

If you **did not** check the Anti-Intrusion box and choose a proper profile for Anti-Virus/Anti-Spam, you still **cannot use** the Anti-Intrusion/Anti-Virus/Anti-Spam function even if you finished all the relational profiles.

# 5

## Application and Examples

### 5.1 Create a LAN-to-LAN Connection Between Remote Office and Headquarter

The most common case is that you may want to connect to network securely, such as the remote branch office and headquarter. According to the network structure as shown in the below illustration, you may follow the steps to create a LAN-to-LAN profile. These two networks (LANs) should NOT have the same network address.

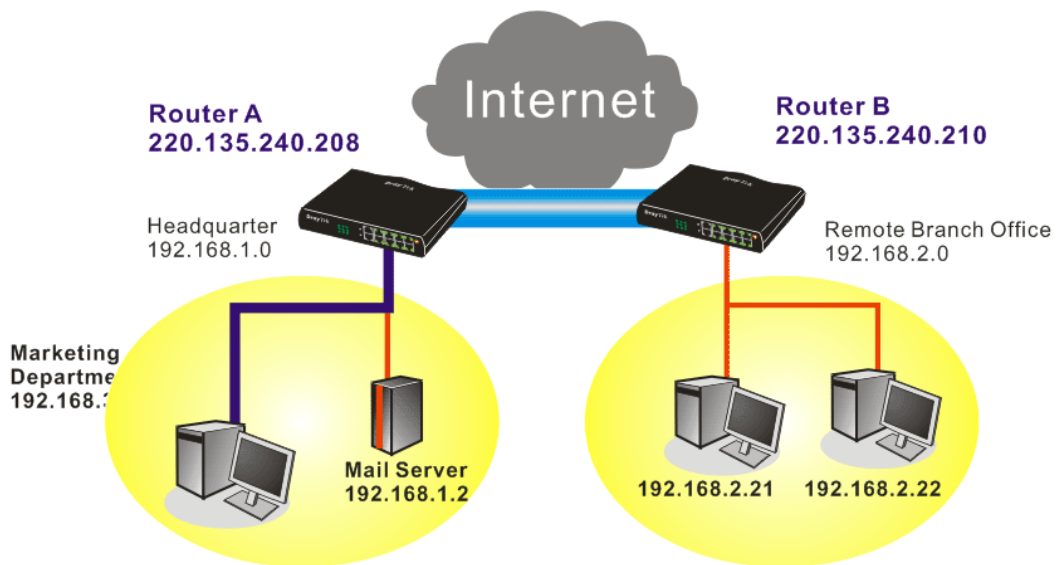

#### Settings in Router A in headquarter:

1. Go to **VPN and Remote Access** and select **Remote Access Control** to enable the necessary VPN service and click **OK**.
2. Then,  
For using **PPP** based services, such as PPTP, L2TP, you have to set general settings in **PPP General Setup**.

#### VPN and Remote Access >> PPP General Setup

PPP General Setup	
<b>PPP/MP Protocol</b>	<b>IP Address Assignment for Dial-In Users</b>
Dial-In PPP Authentication	Start IP Address
<input type="text" value="PAP or CHAP"/>	<input type="text" value="192.168.1.200"/>
Dial-In PPP Encryption (MPPE)	
<input type="text" value="Optional MPPE"/>	
Mutual Authentication (PAP)	
<input type="radio"/> Yes <input checked="" type="radio"/> No	
Username	
<input type="text"/>	
Password	
<input type="text"/>	

OK

For using **IPSec**-based service, such as IPSec or L2TP with IPSec Policy, you have to set general settings in **IPSec General Setup**, such as the pre-shared key that both parties have known.

VPN and Remote Access >> IPSec General Setup

**VPN IKE/IPSec General Setup**

Dial-in Set up for Remote Dial-in users and Dynamic IP Client (LAN to LAN).

<b>IKE Authentication Method</b>	
Pre-Shared Key	.....
Re-type Pre-Shared Key	.....
<b>IPSec Security Method</b>	
<input checked="" type="checkbox"/> Medium (AH)	Data will be authentic, but will not be encrypted.
High (ESP)	<input checked="" type="checkbox"/> DES <input checked="" type="checkbox"/> 3DES <input checked="" type="checkbox"/> AES
Data will be encrypted and authentic.	

OK Cancel

3. Go to **LAN-to-LAN**. Click on one index number to edit a profile.
4. Set **Common Settings** as shown below. You should enable both of VPN connections because any one of the parties may start the VPN connection.

VPN and Remote Access >> LAN to LAN

Profile Index : 1

**1. Common Settings**

Profile Name	Branch1	Call Direction	<input checked="" type="radio"/> Both <input type="radio"/> Dial-Out <input type="radio"/> Dial-In
<input checked="" type="checkbox"/> Enable this profile		<input type="checkbox"/> Always on	
VPN Connection Through:	WAN1 First	Idle Timeout	300 second(s)
		<input type="checkbox"/> Enable PING to keep alive	
		PING to the IP	

5. Set **Dial-Out Settings** as shown below to dial to connect to Router B aggressively with the selected Dial-Out method.  
If an **IPSec-based** service is selected, you should further specify the remote peer IP Address, IKE Authentication Method and IPSec Security Method for this Dial-Out connection.

## 2. Dial-Out Settings

<b>Type of Server I am calling</b> <input type="radio"/> ISDN <input type="radio"/> PPTP <input checked="" type="radio"/> IPsec Tunnel <input type="radio"/> L2TP with IPsec Policy <span>None</span>	Link Type <span>64k bps</span> Username <span>???</span> Password <span></span> PPP Authentication <span>PAP/CHAP</span> VJ Compression <input checked="" type="radio"/> On <input type="radio"/> Off
Dial Number for ISDN or Server IP/Host Name for VPN. (such as 5551234, draytek.com or 123.45.67.89) <span>220.135.240.210</span>	<b>IKE Authentication Method</b> <input checked="" type="radio"/> Pre-Shared Key IKE Pre-Shared Key <span></span> <input type="radio"/> Digital Signature(X.509) <span>None</span>
	<b>IPsec Security Method</b> <input checked="" type="radio"/> Medium(AH) <input type="radio"/> High(ESP) <span>DES without Authentication</span> <span>Advanced</span>
	Index(1-15) in <b>Schedule</b> Setup: <span></span> <span></span> <span></span> <span></span>
	<b>Callback Function (CBCP)</b> <input type="checkbox"/> Require Remote to Callback <input type="checkbox"/> Provide ISDN Number to Remote

If a **PPP-based service** is selected, you should further specify the remote peer IP Address, Username, Password, PPP Authentication and VJ Compression for this Dial-Out connection.

## 2. Dial-Out Settings

<b>Type of Server I am calling</b> <input type="radio"/> ISDN <input checked="" type="radio"/> PPTP <input type="radio"/> IPsec Tunnel <input type="radio"/> L2TP with IPsec Policy <span>None</span>	Link Type <span>64k bps</span> Username <span>draytek</span> Password <span>*****</span> PPP Authentication <span>PAP/CHAP</span> VJ Compression <input checked="" type="radio"/> On <input type="radio"/> Off
Dial Number for ISDN or Server IP/Host Name for VPN. (such as 5551234, draytek.com or 123.45.67.89) <span>220.135.240.210</span>	<b>IKE Authentication Method</b> <input checked="" type="radio"/> Pre-Shared Key IKE Pre-Shared Key <span></span> <input type="radio"/> Digital Signature(X.509) <span>None</span>
	<b>IPsec Security Method</b> <input checked="" type="radio"/> Medium(AH) <input type="radio"/> High(ESP) <span>DES without Authentication</span> <span>Advanced</span>
	Index(1-15) in <b>Schedule</b> Setup: <span></span> <span></span> <span></span> <span></span>
	<b>Callback Function (CBCP)</b> <input type="checkbox"/> Require Remote to Callback <input type="checkbox"/> Provide ISDN Number to Remote

- Set **Dial-In settings** to as shown below to allow Router B dial-in to build VPN connection.

If an **IPsec-based** service is selected, you may further specify the remote peer IP Address, IKE Authentication Method and IPsec Security Method for this Dial-In connection. Otherwise, it will apply the settings defined in **IPsec General Setup** above.

### 3. Dial-In Settings

<p><b>Allowed Dial-In Type</b></p> <p><input type="checkbox"/> ISDN</p> <p><input type="checkbox"/> PPTP</p> <p><input checked="" type="checkbox"/> IPsec Tunnel</p> <p><input type="checkbox"/> L2TP with IPsec Policy <span style="border: 1px solid black; padding: 0 5px;">None</span></p> <p><input checked="" type="checkbox"/> Specify ISDN CLID or Remote VPN Gateway Peer ISDN Number or Peer VPN Server IP <span style="border: 1px solid black; padding: 0 20px;">220.135.240.210</span></p> <p>or Peer ID <span style="border: 1px solid black; padding: 0 20px;"></span></p>	<p>Username <span style="border: 1px solid black; padding: 0 20px;">???</span></p> <p>Password <span style="border: 1px solid black; padding: 0 20px;"></span></p> <p>VJ Compression <input checked="" type="radio"/> On <input type="radio"/> Off</p> <hr/> <p><b>IKE Authentication Method</b></p> <p><input checked="" type="checkbox"/> Pre-Shared Key</p> <p><span style="border: 1px solid black; padding: 0 20px;">IKE Pre-Shared Key</span> <span style="border: 1px solid black; padding: 0 20px;"></span></p> <p><input type="checkbox"/> Digital Signature(X.509)</p> <p><span style="border: 1px solid black; padding: 0 5px;">None</span></p> <hr/> <p><b>IPsec Security Method</b></p> <p><input checked="" type="checkbox"/> Medium (AH)</p> <p>High (ESP)</p> <p><input checked="" type="checkbox"/> DES <input checked="" type="checkbox"/> 3DES <input checked="" type="checkbox"/> AES</p> <hr/> <p><b>Callback Function (CBCP)</b></p> <p><input type="checkbox"/> Enable Callback Function</p> <p><input type="checkbox"/> Use the Following Number to Callback</p> <p>Callback Number <span style="border: 1px solid black; padding: 0 20px;"></span></p> <p>Callback Budget <span style="border: 1px solid black; padding: 0 5px;">0</span> minute(s)</p>
---	--

If a **PPP-based service** is selected, you should further specify the remote peer IP Address, Username, Password, and VJ Compression for this Dial-In connection.

### 3. Dial-In Settings

<p><b>Allowed Dial-In Type</b></p> <p><input type="checkbox"/> ISDN</p> <p><input checked="" type="checkbox"/> PPTP</p> <p><input type="checkbox"/> IPsec Tunnel</p> <p><input type="checkbox"/> L2TP with IPsec Policy <span style="border: 1px solid black; padding: 0 5px;">None</span></p> <p><input checked="" type="checkbox"/> Specify ISDN CLID or Remote VPN Gateway Peer ISDN Number or Peer VPN Server IP <span style="border: 1px solid black; padding: 0 20px;">220.135.240.210</span></p> <p>or Peer ID <span style="border: 1px solid black; padding: 0 20px;"></span></p>	<p>Username <span style="border: 1px solid black; padding: 0 20px;">draytek</span></p> <p>Password <span style="border: 1px solid black; padding: 0 20px;">●●●●●●</span></p> <p>VJ Compression <input checked="" type="radio"/> On <input type="radio"/> Off</p> <hr/> <p><b>IKE Authentication Method</b></p> <p><input checked="" type="checkbox"/> Pre-Shared Key</p> <p><span style="border: 1px solid black; padding: 0 20px;">IKE Pre-Shared Key</span> <span style="border: 1px solid black; padding: 0 20px;"></span></p> <p><input type="checkbox"/> Digital Signature(X.509)</p> <p><span style="border: 1px solid black; padding: 0 5px;">None</span></p> <hr/> <p><b>IPsec Security Method</b></p> <p><input checked="" type="checkbox"/> Medium (AH)</p> <p>High (ESP)</p> <p><input checked="" type="checkbox"/> DES <input checked="" type="checkbox"/> 3DES <input checked="" type="checkbox"/> AES</p> <hr/> <p><b>Callback Function (CBCP)</b></p> <p><input type="checkbox"/> Enable Callback Function</p> <p><input type="checkbox"/> Use the Following Number to Callback</p> <p>Callback Number <span style="border: 1px solid black; padding: 0 20px;"></span></p> <p>Callback Budget <span style="border: 1px solid black; padding: 0 5px;">0</span> minute(s)</p>
---	--

- At last, set the remote network IP/subnet in **TCP/IP Network Settings** so that Router A can direct the packets destined to the remote network to Router B via the VPN connection.

### 4. TCP/IP Network Settings

<p>My WAN IP <span style="border: 1px solid black; padding: 0 20px;">0.0.0.0</span></p> <p>Remote Gateway IP <span style="border: 1px solid black; padding: 0 20px;">0.0.0.0</span></p> <p>Remote Network IP <span style="border: 1px solid black; padding: 0 20px;">192.168.2.0</span></p> <p>Remote Network Mask <span style="border: 1px solid black; padding: 0 20px;">255.255.255.0</span></p> <p style="text-align: center;"><span style="border: 1px solid black; padding: 2px 5px;">More</span></p>	<p>RIP Direction <span style="border: 1px solid black; padding: 0 5px;">Disable</span></p> <p>From first subnet to remote network, you have to do</p> <p style="text-align: center;"><span style="border: 1px solid black; padding: 2px 5px;">Route</span></p> <hr/> <p><input type="checkbox"/> Change default route to this VPN tunnel ( Only single WAN supports this )</p>
---	--

OK
Clear
Cancel

### Settings in Router B in the remote office:

- Go to **VPN and Remote Access** and select **Remote Access Control** to enable the necessary VPN service and click **OK**.



- Then, for using **PPP based** services, such as PPTP, L2TP, you have to set general settings in **PPP General Setup**.

VPN and Remote Access >> PPP General Setup

**PPP General Setup**

<p><b>PPP/MP Protocol</b></p> <p>Dial-In PPP Authentication <input type="text" value="PAP or CHAP"/></p> <p>Dial-In PPP Encryption (MPPE) <input type="text" value="Optional MPPE"/></p> <p>Mutual Authentication (PAP) <input type="radio"/> Yes <input checked="" type="radio"/> No</p> <p>Username <input type="text"/></p> <p>Password <input type="text"/></p>	<p><b>IP Address Assignment for Dial-In Users</b></p> <p>Start IP Address <input type="text" value="192.168.2.200"/></p>
---	--

For using **IPSec-based** service, such as IPSec or L2TP with IPSec Policy, you have to set general settings in **IPSec General Setup**, such as the pre-shared key that both parties have known.

VPN and Remote Access >> IPSec General Setup

**VPN IKE/IPSec General Setup**

Dial-in Set up for Remote Dial-in users and Dynamic IP Client (LAN to LAN).

<p><b>IKE Authentication Method</b></p> <p>Pre-Shared Key <input type="text" value="....."/></p> <p>Re-type Pre-Shared Key <input type="text" value="....."/></p> <p><b>IPSec Security Method</b></p> <p><input checked="" type="checkbox"/> Medium (AH) Data will be authentic, but will not be encrypted.</p> <p>High (ESP) <input checked="" type="checkbox"/> DES <input checked="" type="checkbox"/> 3DES <input checked="" type="checkbox"/> AES Data will be encrypted and authentic.</p>
--

- Go to **LAN-to-LAN**. Click on one index number to edit a profile.
- Set **Common Settings** as shown below. You should enable both of VPN connections because any one of the parties may start the VPN connection.

VPN and Remote Access >> LAN to LAN

**Profile Index : 1**

**1. Common Settings**

<p>Profile Name <input type="text" value="Branch1"/></p> <p><input checked="" type="checkbox"/> Enable this profile</p> <p>VPN Connection Through: <input type="text" value="WAN1 First"/></p>	<p>Call Direction <input checked="" type="radio"/> Both <input type="radio"/> Dial-Out <input type="radio"/> Dial-In</p> <p><input type="checkbox"/> Always on</p> <p>Idle Timeout <input type="text" value="300"/> second(s)</p> <p><input type="checkbox"/> Enable PING to keep alive</p> <p>PING to the IP <input type="text"/></p>
--	--

- Set **Dial-Out Settings** as shown below to dial to connect to Router B aggressively with the selected Dial-Out method.

If an **IPSec-based** service is selected, you should further specify the remote peer IP Address, IKE Authentication Method and IPSec Security Method for this Dial-Out

connection.

## 2. Dial-Out Settings

<b>Type of Server I am calling</b> <input type="radio"/> ISDN <input type="radio"/> PPTP <input checked="" type="radio"/> IPsec Tunnel <input type="radio"/> L2TP with IPsec Policy <span>None</span>	Link Type <span>64k bps</span> Username <span>???</span> Password <span></span> PPP Authentication <span>PAP/CHAP</span> VJ Compression <input checked="" type="radio"/> On <input type="radio"/> Off
Dial Number for ISDN or Server IP/Host Name for VPN. (such as 5551234, draytek.com or 123.45.67.89) <span>220.135.240.208</span>	<b>IKE Authentication Method</b> <input checked="" type="radio"/> Pre-Shared Key IKE Pre-Shared Key <span></span> <input type="radio"/> Digital Signature(X.509) <span>None</span>
	<b>IPsec Security Method</b> <input checked="" type="radio"/> Medium(AH) <input type="radio"/> High(ESP) <span>DES without Authentication</span> <span>Advanced</span>
	Index(1-15) in <b>Schedule</b> Setup: <span></span> <span></span> <span></span> <span></span>
	<b>Callback Function (CBCP)</b> <input type="checkbox"/> Require Remote to Callback <input type="checkbox"/> Provide ISDN Number to Remote

If a **PPP-based** service is selected, you should further specify the remote peer IP Address, Username, Password, PPP Authentication and VJ Compression for this Dial-Out connection.

## 2. Dial-Out Settings

<b>Type of Server I am calling</b> <input type="radio"/> ISDN <input checked="" type="radio"/> PPTP <input type="radio"/> IPsec Tunnel <input type="radio"/> L2TP with IPsec Policy <span>None</span>	Link Type <span>64k bps</span> Username <span>draytek</span> Password <span>•••••</span> PPP Authentication <span>PAP/CHAP</span> VJ Compression <input checked="" type="radio"/> On <input type="radio"/> Off
Dial Number for ISDN or Server IP/Host Name for VPN. (such as 5551234, draytek.com or 123.45.67.89) <span>220.135.240.208</span>	<b>IKE Authentication Method</b> <input checked="" type="radio"/> Pre-Shared Key IKE Pre-Shared Key <span></span> <input type="radio"/> Digital Signature(X.509) <span>None</span>
	<b>IPsec Security Method</b> <input checked="" type="radio"/> Medium(AH) <input type="radio"/> High(ESP) <span>DES without Authentication</span> <span>Advanced</span>
	Index(1-15) in <b>Schedule</b> Setup: <span></span> <span></span> <span></span> <span></span>
	<b>Callback Function (CBCP)</b> <input type="checkbox"/> Require Remote to Callback <input type="checkbox"/> Provide ISDN Number to Remote

6. Set **Dial-In settings** to as shown below to allow Router A dial-in to build VPN connection.

If an **IPsec-based** service is selected, you may further specify the remote peer IP Address, IKE Authentication Method and IPsec Security Method for this Dial-In connection. Otherwise, it will apply the settings defined in **IPsec General Setup** above.

### 3. Dial-In Settings

<b>Allowed Dial-In Type</b> <input type="checkbox"/> ISDN <input type="checkbox"/> pPTP <input checked="" type="checkbox"/> IPsec Tunnel <input type="checkbox"/> L2TP with IPsec Policy <input type="text" value="None"/>  <input checked="" type="checkbox"/> Specify ISDN CLID or Remote VPN Gateway Peer ISDN Number or Peer VPN Server IP <input type="text" value="220.135.240.208"/> or Peer ID <input type="text"/>	Username <input type="text" value="???"/> Password <input type="text"/> VJ Compression <input checked="" type="radio"/> On <input type="radio"/> Off  <b>IKE Authentication Method</b> <input checked="" type="checkbox"/> Pre-Shared Key IKE Pre-Shared Key <input type="text"/> <input type="checkbox"/> Digital Signature(X.509) <input type="text" value="None"/>  <b>IPsec Security Method</b> <input checked="" type="checkbox"/> Medium (AH) High (ESP) <input checked="" type="checkbox"/> DES <input checked="" type="checkbox"/> 3DES <input checked="" type="checkbox"/> AES  <b>Callback Function (CBCP)</b> <input type="checkbox"/> Enable Callback Function <input type="checkbox"/> Use the Following Number to Callback Callback Number <input type="text"/> Callback Budget <input type="text" value="0"/> minute(s)
--	---

If a **PPP-based** service is selected, you should further specify the remote peer IP Address, Username, Password, and VJ Compression for this Dial-In connection.

### 3. Dial-In Settings

<b>Allowed Dial-In Type</b> <input type="checkbox"/> ISDN <input checked="" type="checkbox"/> pPTP <input type="checkbox"/> IPsec Tunnel <input type="checkbox"/> L2TP with IPsec Policy <input type="text" value="None"/>  <input checked="" type="checkbox"/> Specify ISDN CLID or Remote VPN Gateway Peer ISDN Number or Peer VPN Server IP <input type="text" value="220.135.240.208"/> or Peer ID <input type="text"/>	Username <input type="text" value="draytek"/> Password <input type="text" value="*****"/> VJ Compression <input checked="" type="radio"/> On <input type="radio"/> Off  <b>IKE Authentication Method</b> <input checked="" type="checkbox"/> Pre-Shared Key IKE Pre-Shared Key <input type="text"/> <input type="checkbox"/> Digital Signature(X.509) <input type="text" value="None"/>  <b>IPsec Security Method</b> <input checked="" type="checkbox"/> Medium (AH) High (ESP) <input checked="" type="checkbox"/> DES <input checked="" type="checkbox"/> 3DES <input checked="" type="checkbox"/> AES  <b>Callback Function (CBCP)</b> <input type="checkbox"/> Enable Callback Function <input type="checkbox"/> Use the Following Number to Callback Callback Number <input type="text"/> Callback Budget <input type="text" value="0"/> minute(s)
--	---

- At last, set the remote network IP/subnet in **TCP/IP Network Settings** so that Router B can direct the packets destined to the remote network to Router A via the VPN connection.

### 4. TCP/IP Network Settings

My WAN IP <input type="text" value="0.0.0.0"/> Remote Gateway IP <input type="text" value="0.0.0.0"/> Remote Network IP <input type="text" value="192.168.1.0"/> Remote Network Mask <input type="text" value="255.255.255.0"/> <input type="button" value="More"/>	RIP Direction <input type="text" value="Disable"/> From first subnet to remote network, you have to do <input type="text" value="Route"/>  <input type="checkbox"/> Change default route to this VPN tunnel ( Only single WAN supports this )
---	---

## 5.2 Create a Remote Dial-in User Connection Between the Teleworker and Headquarter

The other common case is that you, as a teleworker, may want to connect to the enterprise network securely. According to the network structure as shown in the below illustration, you may follow the steps to create a Remote User Profile and install Smart VPN Client on the remote host.

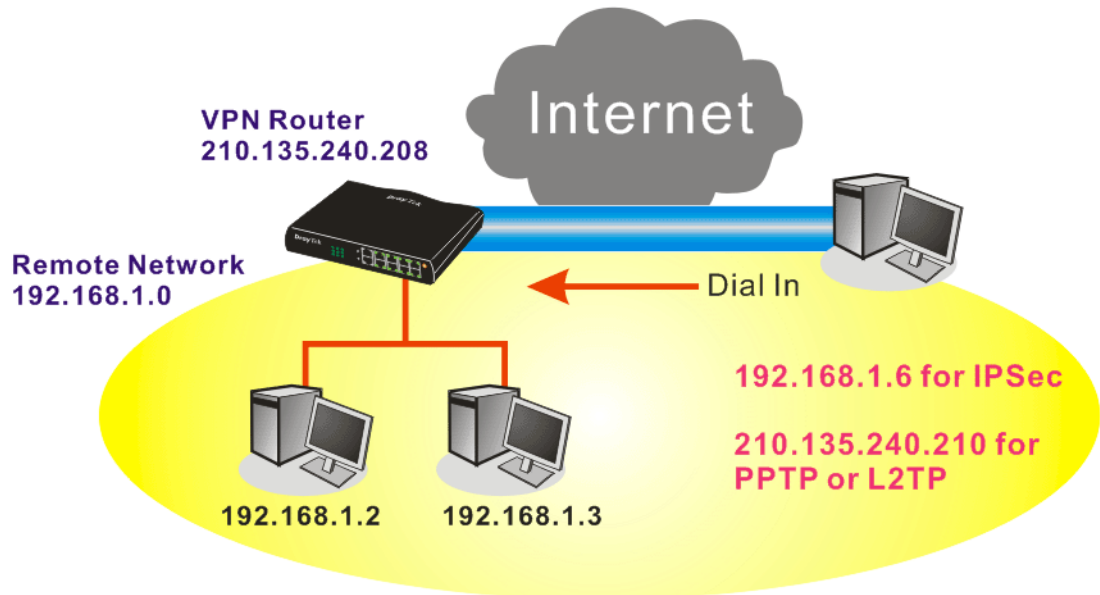

### Settings in VPN Router in the enterprise office:

1. Go to **VPN and Remote Access** and select **Remote Access Control** to enable the necessary VPN service and click **OK**.
2. Then, for using PPP based services, such as PPTP, L2TP, you have to set general settings in **PPP General Setup**.

VPN and Remote Access >> PPP General Setup

PPP General Setup	
<b>PPP/MP Protocol</b>	
Dial-In PPP Authentication	PAP or CHAP
Dial-In PPP Encryption (MPPE)	Optional MPPE
Mutual Authentication (PAP)	<input type="radio"/> Yes <input checked="" type="radio"/> No
Username	<input type="text"/>
Password	<input type="text"/>
<b>IP Address Assignment for Dial-In Users</b>	
Start IP Address	192.168.1.200

OK

For using IPsec-based service, such as IPsec or L2TP with IPsec Policy, you have to set general settings in **IKE/IPsec General Setup**, such as the pre-shared key that both parties have known.

VPN and Remote Access >> IPSec General Setup

VPN IKE/IPSec General Setup

Dial-in Set up for Remote Dial-in users and Dynamic IP Client (LAN to LAN).

<b>IKE Authentication Method</b>	
Pre-Shared Key	●●●●
Re-type Pre-Shared Key	●●●●
<b>IPSec Security Method</b>	
<input checked="" type="checkbox"/> Medium (AH)	Data will be authentic, but will not be encrypted.
High (ESP)	<input checked="" type="checkbox"/> DES <input checked="" type="checkbox"/> 3DES <input checked="" type="checkbox"/> AES
Data will be encrypted and authentic.	

OK Cancel

3. Go to **Remote Dial-In Users**. Click on one index number to edit a profile.
4. Set **Dial-In** settings to as shown below to allow the remote user dial-in to build VPN connection.

If an **IPSec** service is selected, you may further specify the remote peer IP Address, IKE Authentication Method and IPSec Security Method for this Dial-In connection. Otherwise, it will apply the settings defined in **IPSec General Setup** above.

VPN and Remote Access >> Remote Dial-in User

Index No. 1

<b>User account and Authentication</b> <input checked="" type="checkbox"/> Enable this account Idle Timeout: 300 second(s)	Username: ??? Password:
<b>Allowed Dial-In Type</b> <input type="checkbox"/> ISDN <input type="checkbox"/> PPTP <input checked="" type="checkbox"/> IPSec Tunnel <input type="checkbox"/> L2TP with IPSec Policy: None	<b>IKE Authentication Method</b> <input checked="" type="checkbox"/> Pre-Shared Key IKE Pre-Shared Key: <input type="checkbox"/> Digital Signature (X.509) None
<input checked="" type="checkbox"/> Specify Remote Node Remote Client IP or Peer ISDN Number: 210.135.240.210 or Peer ID:	<b>IPSec Security Method</b> <input checked="" type="checkbox"/> Medium (AH) High (ESP) <input checked="" type="checkbox"/> DES <input checked="" type="checkbox"/> 3DES <input checked="" type="checkbox"/> AES Local ID: (optional)
	<b>Callback Function</b> <input type="checkbox"/> Check to enable Callback function <input type="checkbox"/> Specify the callback number Callback Number: <input checked="" type="checkbox"/> Check to enable Callback Budget Control Callback Budget: 30 minute(s)

OK Clear Cancel

If a **PPTP** service is selected, you should further specify the remote peer IP Address, Username, Password, and VJ Compression for this Dial-In connection.

**Index No. 1**

<b>User account and Authentication</b> <input checked="" type="checkbox"/> Enable this account Idle Timeout: <input type="text" value="300"/> second(s)		Username: <input type="text" value="???"/> Password: <input type="password"/>
<b>Allowed Dial-In Type</b> <input type="checkbox"/> ISDN <input checked="" type="checkbox"/> PPTP <input type="checkbox"/> IPsec Tunnel <input type="checkbox"/> L2TP with IPsec Policy: <input type="text" value="None"/>		<b>IKE Authentication Method</b> <input checked="" type="checkbox"/> Pre-Shared Key IKE Pre-Shared Key: <input type="text"/> <input type="checkbox"/> Digital Signature (X.509) <input type="text" value="None"/>
<input checked="" type="checkbox"/> Specify Remote Node Remote Client IP or Peer ISDN Number: <input type="text" value="210.135.240.210"/> or Peer ID: <input type="text"/>		<b>IPsec Security Method</b> <input checked="" type="checkbox"/> Medium (AH) <input checked="" type="checkbox"/> High (ESP) <input checked="" type="checkbox"/> DES <input checked="" type="checkbox"/> 3DES <input checked="" type="checkbox"/> AES Local ID: <input type="text"/> (optional)
<b>Callback Function</b> <input type="checkbox"/> Check to enable Callback function <input type="checkbox"/> Specify the callback number Callback Number: <input type="text"/> <input checked="" type="checkbox"/> Check to enable Callback Budget Control Callback Budget: <input type="text" value="30"/> minute(s)		

### Settings in the remote host:

- For Win98/ME, you may use "Dial-up Networking" to create the PPTP tunnel to Vigor router. For Win2000/XP, please use "Network and Dial-up connections" or "Smart VPN Client", complimentary software to help you create PPTP, L2TP, and L2TP over IPsec tunnel. You can find it in CD-ROM in the package or go to [www.draytek.com](http://www.draytek.com) download center. Install as instructed.
- After successful installation, for the first time user, you should click on the **Step 0. Configure** button. Reboot the host.

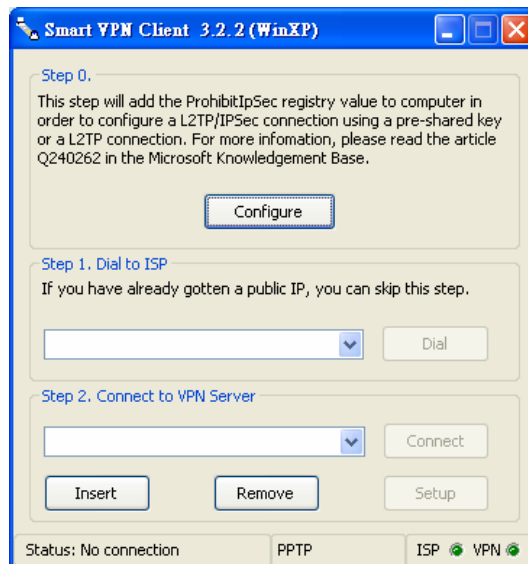

- In **Step 2. Connect to VPN Server**, click **Insert** button to add a new entry.

If an IPsec-based service is selected as shown below,

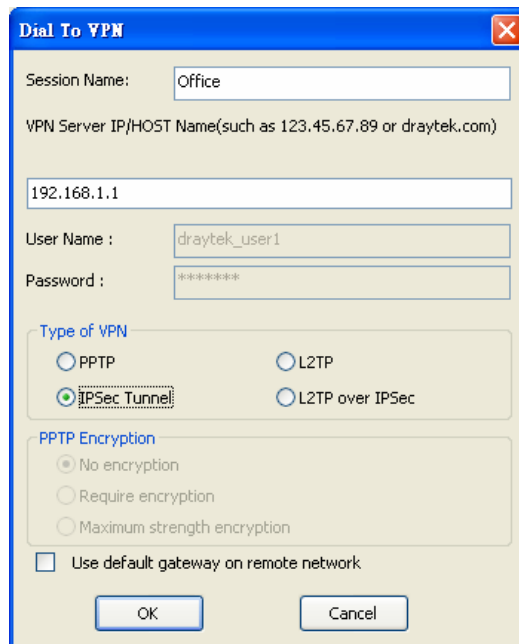

You may further specify the method you use to get IP, the security method, and authentication method. If the Pre-Shared Key is selected, it should be consistent with the one set in VPN router.

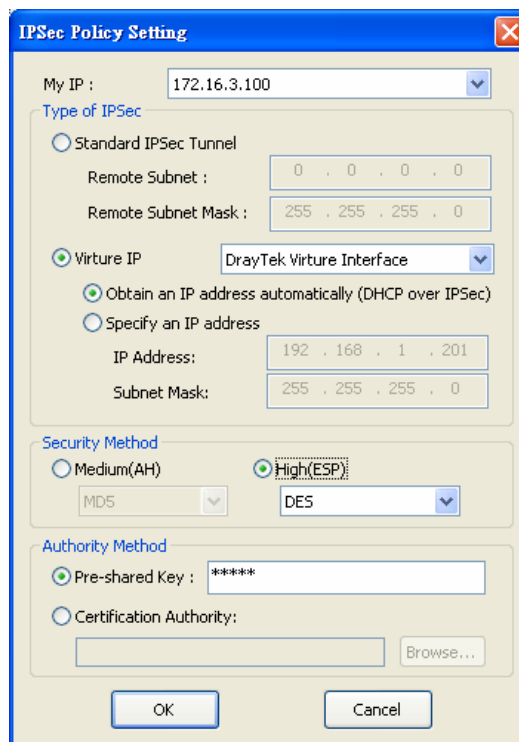

If a PPP-based service is selected, you should further specify the remote VPN server IP address, Username, Password, and encryption method. The User Name and Password should be consistent with the one set up in the VPN router. To use default gateway on remote network means that all the packets of remote host will be directed to VPN server then forwarded to Internet. This will make the remote host seem to be working in the enterprise network.

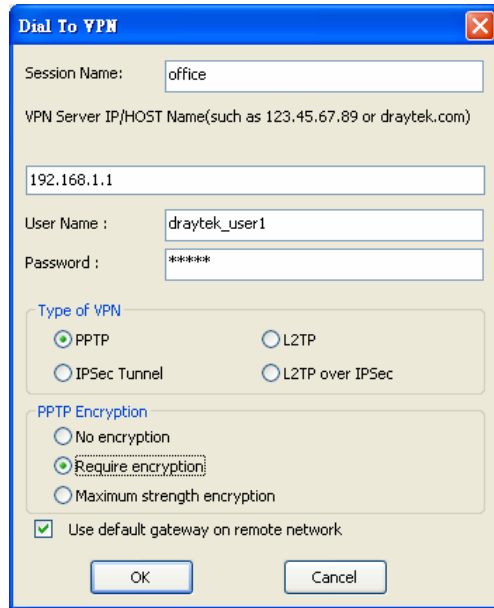

- Click **Connect** button to build connection. When the connection is successful, you will find a green light on the right down corner.

## 5.3 QoS Setting Example

Assume a teleworker sometimes works at home and takes care of children. When working time, he would use Vigor router at home to connect to the server in the headquarter office downtown via either HTTPS or VPN to check email and access internal database. Meanwhile, children may chat on Skype in the restroom.

- Go to **Bandwidth Management >> Quality of Service**.

Bandwidth Management >> Quality of Service

### General Setup

Index	Status	Bandwidth	Direction	Class 1	Class 2	Class 3	Others	UDP Bandwidth Control	
WAN1	Disable	10000Kbps/10000Kbps		25%	25%	25%	25%	Inactive	<a href="#">Setup</a>
WAN2	Disable	10000Kbps/10000Kbps		25%	25%	25%	25%	Inactive	<a href="#">Setup</a>

### Class Rule

Index	Name	Rule	Service Type
Class 1		<a href="#">Edit</a>	<a href="#">Edit</a>
Class 2		<a href="#">Edit</a>	
Class 3		<a href="#">Edit</a>	

- Click **Setup** link for WAN1. Make sure the QoS Control on the left corner is checked. And select **BOTH** as the **Direction**.

### WAN1 General Setup

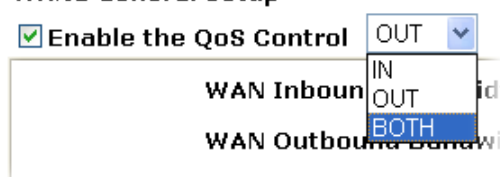

- Set Inbound/Outbound bandwidth.



Bandwidth Management >> Quality of Service

WAN1 General Setup

Enable the QoS Control BOTH

WAN Inbound Bandwidth  Kbps  
WAN Outbound Bandwidth  Kbps

**Note:** The rate of outbound/inbound must be smaller than the real bandwidth to ensure correct calculation of QoS. It is suggested to set the bandwidth value for inbound/outbound as 80% - 85% of physical network speed provided by ISP to maximize the QoS performance.

- Return to previous page. Enter the Name of Index Class 1 by clicking **Edit** link. Type the name “**E-mail**” for Class 1.

Bandwidth Management >> Quality of Service

**Class Index # 1**  
Name

NO	Status	Local Address	Remote Address	DiffServ CodePoint	Service Type
1	Active	Any	Any	IP precedence 2	SMTP(TCP:25)

- For this index, the user will set reserved bandwidth (e.g., 25%) for **Email** using protocol POP3 and SMTP.

Bandwidth Management >> Quality of Service

WAN1 General Setup

Enable the QoS Control BOTH

WAN Inbound Bandwidth  Kbps  
WAN Outbound Bandwidth  Kbps

Index	Class Name	Reserved bandwidth Ratio
Class 1	E-mail	<input type="text" value="25"/> %
Class 2		<input type="text" value="25"/> %
Class 3		<input type="text" value="25"/> %
	Others	<input type="text" value="25"/> %

Enable UDP Bandwidth Control Limited\_bandwidth Ratio  %  
 Outbound TCP ACK Prioritize

- Return to previous page. Enter the Name of Index Class 2 by clicking **Edit** link. In this index, the user will set reserved bandwidth (e.g., 25%) for **HTTPS**.

Bandwidth Management >> Quality of Service

Class Index #2

Name

NO	Status	Local Address	Remote Address	DiffServ CodePoint	Service Type
1 <input type="radio"/>	Active	Any	Any	IP precedence 2	SQL-NET (TCP:1521)

- Click **Setup** link for WAN1.

Bandwidth Management >> Quality of Service

General Setup

| [Set to Factory Default](#) |

Index	Status	Bandwidth	Direction	Class 1	Class 2	Class 3	Others	UDP Bandwidth Control	
WAN1	Disable	10000Kbps/10000Kbps		25%	25%	25%	25%	Inactive	<a href="#">Setup</a>
WAN2	Disable	10000Kbps/10000Kbps		25%	25%	25%	25%	Inactive	<a href="#">Setup</a>

Class Rule

Index	Name	Rule	Service Type
Class 1	E-mail	<a href="#">Edit</a>	
Class 2	HTTPS	<a href="#">Edit</a>	<a href="#">Edit</a>
Class 3		<a href="#">Edit</a>	

- Check **Enable UDP Bandwidth Control** on the bottom to prevent enormous UDP traffic of VoIP influent other application, and click OK.

Bandwidth Management >> Quality of Service

WAN1 General Setup

Enable the QoS Control

WAN Inbound Bandwidth	<input type="text" value="10000"/> Kbps
WAN Outbound Bandwidth	<input type="text" value="10000"/> Kbps

Index	Class Name	Reserved_bandwidth Ratio
Class 1	E-mail	<input type="text" value="25"/> %
Class 2	HTTPS	<input type="text" value="25"/> %
Class 3		<input type="text" value="25"/> %
	Others	<input type="text" value="25"/> %

Enable UDP Bandwidth Control Limited\_bandwidth Ratio  %  
 Outbound TCP ACK Prioritize

- If the worker has connected to the headquarter using host to host VPN tunnel. (Please refer to Chapter 3 VPN for detail instruction), he may set up an index for it. Enter the Class Name of Index 3. In this index, he will set reserve bandwidth for 1 VPN tunnel.

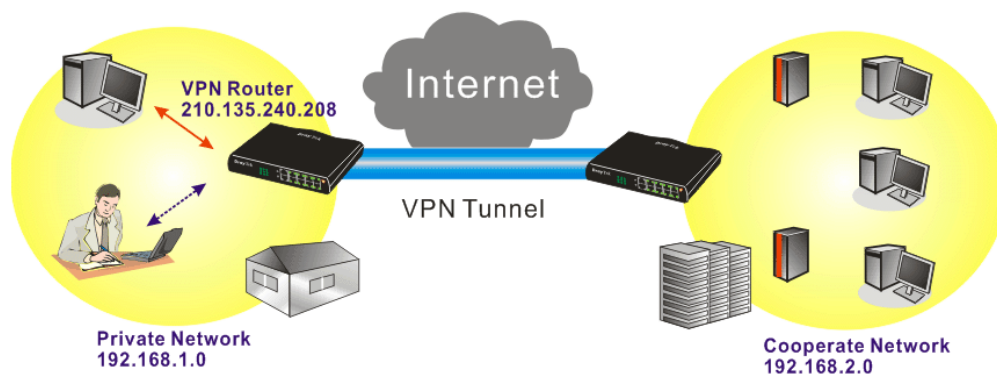

- Click edit to open a new window.

Bandwidth Management >> Quality of Service

#### Class Index # 1

Name

NO	Status	Local Address	Remote Address	DiffServ CodePoint	Service Type
1	Empty	-	-	-	-

- First, check the **ACT** box. Then click **Edit** of **Local Address** to set a worker's subnet address. Click **Edit** of **Remote Address** to set headquarter's subnet address. Leave other fields and click **OK**.

Bandwidth Management >> Quality of Service

#### Rule Edit

ACT

Local Address

Remote Address

DiffServ CodePoint

Service Type

**Note:** Please choose/setup the **Service Type** first.

## 5.4 LAN – Created by Using NAT

An example of default setting and the corresponding deployment are shown below. The default Vigor router private IP address/Subnet Mask is 192.168.1.1/255.255.255.0. The built-in DHCP server is enabled so it assigns every local NATed host an IP address of 192.168.1.x starting from 192.168.1.10.

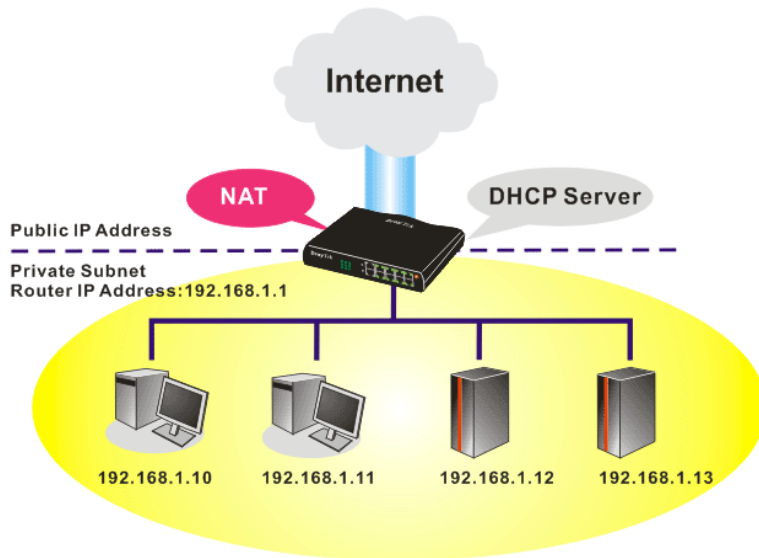

You can just set the settings wrapped inside the red rectangles to fit the request of NAT usage.

LAN >> General Setup

**Ethernet TCP / IP and DHCP Setup**

<b>LAN IP Network Configuration</b>		<b>DHCP Server Configuration</b>	
For NAT Usage		<input checked="" type="radio"/> Enable Server <input type="radio"/> Disable Server	
1st IP Address	<input type="text" value="192.168.1.1"/>	Relay Agent:	<input type="radio"/> 1st Subnet <input type="radio"/> 2nd Subnet
1st Subnet Mask	<input type="text" value="255.255.255.0"/>	Start IP Address	<input type="text" value="192.168.1.10"/>
For IP Routing Usage	<input type="radio"/> Enable <input checked="" type="radio"/> Disable	IP Pool Counts	<input type="text" value="50"/>
2nd IP Address	<input type="text" value="192.168.2.1"/>	Gateway IP Address	<input type="text" value="192.168.1.1"/>
2nd Subnet Mask	<input type="text" value="255.255.255.0"/>	DHCP Server IP Address for Relay Agent	<input type="text"/>
<input type="button" value="2nd Subnet DHCP Server"/>		<b>DNS Server IP Address</b>	
RIP Protocol Control	<input type="text" value="Disable"/>	<input type="checkbox"/> Force DNS manual setting	
		Primary IP Address	<input type="text" value="168.95.1.1"/>
		Secondary IP Address	<input type="text"/>

To use another DHCP server in the network rather than the built-in one of Vigor Router, you have to change the settings as show below.

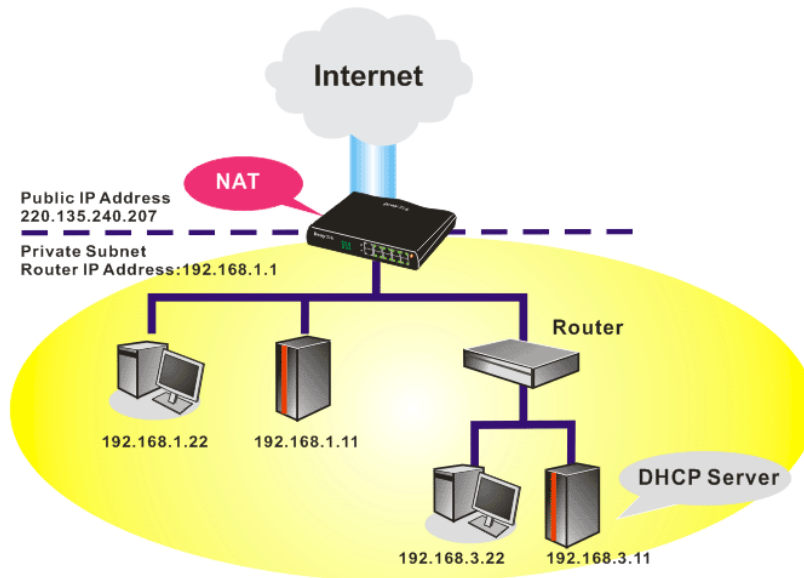

You can just set the settings wrapped inside the red rectangles to fit the request of NAT usage.

LAN >> General Setup

#### Ethernet TCP / IP and DHCP Setup

LAN IP Network Configuration	DHCP Server Configuration
For NAT Usage	<input type="radio"/> Enable Server <input checked="" type="radio"/> Disable Server
1st IP Address <input type="text" value="192.168.1.1"/>	Relay Agent: <input type="radio"/> 1st Subnet <input type="radio"/> 2nd Subnet
1st Subnet Mask <input type="text" value="255.255.255.0"/>	Start IP Address <input type="text" value="192.168.1.10"/>
For IP Routing Usage <input type="radio"/> Enable <input checked="" type="radio"/> Disable	IP Pool Counts <input type="text" value="50"/>
2nd IP Address <input type="text" value="192.168.2.1"/>	Gateway IP Address <input type="text" value="192.168.1.1"/>
2nd Subnet Mask <input type="text" value="255.255.255.0"/>	DHCP Server IP Address for Relay Agent <input type="text"/>
<input type="button" value="2nd Subnet DHCP Server"/>	<b>DNS Server IP Address</b>
RIP Protocol Control <input type="text" value="Disable"/>	<input type="checkbox"/> Force DNS manual setting
	Primary IP Address <input type="text" value="168.95.1.1"/>
	Secondary IP Address <input type="text"/>

## 5.5 Calling Scenario for VoIP function

### 5.5.1 Calling via SIP Sever

**Example 1: Both John and David have SIP Addresses from different service providers.**

John's SIP URL: 1234@draytel.org, David's SIP URL: 4321@iptel.org

#### Settings for John

DialPlan index 1  
Phone Number: 1111  
Display Name: David  
SIP URL: 4321@iptel.org

#### SIP Accounts Settings ---

Profile Name: draytel1  
Register via: Auto  
SIP Port: 5060 (default)  
Domain/Realm: draytel.org  
Proxy: draytel.org  
Act as outbound proxy: unchecked  
Display Name: John  
Account Number/Name: 1234  
Authentication ID: unchecked  
Password: \*\*\*\*  
Expiry Time: (use default value)

**CODEC/RTP/DTMF ---**  
(Use default value)

#### Settings for David

DialPlan index 1  
Phone Number: 2222  
Display Name: John  
SIP URL: 1234@draytel.org

#### SIP Accounts Settings ---

Profile Name: iptel 1  
Register via: Auto  
SIP Port: 5060 (default)  
Domain/Realm: iptel.org  
Proxy: iptel.org  
Act as outbound proxy: unchecked  
Display Name: David  
Account Name: 4321  
Authentication ID: unchecked  
Password: \*\*\*\*  
Expiry Time: (use default value)

**CODEC/RTP/DTMF ---**  
(Use default value)

Phone Book Index No. 1

<input checked="" type="checkbox"/> Enable	
Phone Number	1111
Display Name	David
SIP URL	4321@iptel.org
Loop through	None
Backup Phone Number	

OK Clear Cancel

VoIP >> SIP Accounts

SIP Account Index No. 1

Profile Name	draytel 1 (11 char max.)
Register via	Auto <input type="checkbox"/> Call without Registration
SIP Port	5060
Domain/Realm	draytel.org (63 char max.)
Proxy	draytel.org (63 char max.)
<input type="checkbox"/> Act as outbound proxy	
Display Name	John (23 char max.)
Account Number/Name	1234 (63 char max.)
<input type="checkbox"/> Authentication ID	
Password	**** (63 char max.)
Expiry Time	1 hour 3600 sec
NAT Traversal Support	None
Ring Port	<input checked="" type="checkbox"/> Phone1 <input type="checkbox"/> Phone2 <input type="checkbox"/> ISDN1-S0 <input type="checkbox"/> ISDN2-T8
Ring Pattern	1

OK Cancel

#### John calls David ---

He picks up the phone and dials 1111#. (DialPlan Phone Number for David)

Phone Book Index No. 1

<input checked="" type="checkbox"/> Enable	
Phone Number	2222
Display Name	John
SIP URL	1234@draytel.org
Loop through	None
Backup Phone Number	

OK Clear Cancel

VoIP >> SIP Accounts

SIP Account Index No. 1

Profile Name	iptel 1 (11 char max.)
Register via	Auto <input type="checkbox"/> Call without Registration
SIP Port	5060
Domain/Realm	iptel.org (63 char max.)
Proxy	iptel.org (63 char max.)
<input type="checkbox"/> Act as outbound proxy	
Display Name	David (23 char max.)
Account Number/Name	4321 (63 char max.)
<input type="checkbox"/> Authentication ID	
Password	**** (63 char max.)
Expiry Time	1 hour 3600 sec
NAT Traversal Support	None
Ring Port	<input checked="" type="checkbox"/> Phone1 <input type="checkbox"/> Phone2 <input type="checkbox"/> ISDN1-S0 <input type="checkbox"/> ISDN2-T8
Ring Pattern	1

OK Cancel

#### David calls John

He picks up the phone and dials 2222# (DialPlan Phone Number for John)

**Example 2: Both John and David have SIP Addresses from the same service provider.**

John's SIP URL: 1234@draytel.org , David's SIP URL: 4321@draytel.org

**Settings for John**

DialPlan index 1  
Phone Number: 1111  
Display Name: David  
SIP URL: 4321@draytel.org

Phone Book Index No. 1

Enable

Phone Number: 1111

Display Name: David

SIP URL: 4321 @ draytel.org

Loop through: None

Backup Phone Number

OK Clear Cancel

**SIP Accounts Settings ---**

Profile Name: draytel 1  
Register via: Auto  
SIP Port: 5060 (default)  
Domain/Realm: draytel.org  
Proxy: draytel.org  
Act as outbound proxy: unchecked  
Display Name: John  
Account Number/Name: 1234  
Authentication ID: unchecked  
Password: \*\*\*\*  
Expiry Time: (use default value)

VoIP >> SIP Accounts

SIP Account Index No. 1

Profile Name: draytel 1 (11 char max.)

Register via: Auto  Call without Registration

SIP Port: 5060

Domain/Realm: draytel.org (63 char max.)

Proxy: draytel.org (63 char max.)

Act as outbound proxy

Display Name: John (23 char max.)

Account Number/Name: 1234 (63 char max.)

Authentication ID

Password: \*\*\*\* (63 char max.)

Expiry Time: 1 hour 3600 sec

NAT Traversal Support: None

Ring Port:  Phone1  Phone2  ISDN1-S0 Any  ISDN2-TE

Ring Pattern: 1

OK Cancel

**John calls David**

He picks up the phone and dials 1111#. (DialPlan Phone Number for David) Or,  
He picks up the phone and dials 4321#. (David's Account Name)

**CODEC/RTP/DTMF ---**

(Use default value)

**Settings for David**

DialPlan index 1  
Phone Number: 2222  
Display Name: John  
SIP URL: 1234@draytel.org

Phone Book Index No. 1

Enable

Phone Number: 2222

Display Name: John

SIP URL: 1234 @ draytel.org

Loop through: None

Backup Phone Number

OK Clear Cancel

**SIP Accounts Settings ---**

Profile Name: John  
Register via: Auto  
SIP Port: 5060(default)  
Domain/Realm: draytel.org  
Proxy: iptel.org  
Act as outbound proxy: unchecked  
Display Name: David  
Account Name: 4321  
Authentication ID: unchecked  
Password: \*\*\*\*  
Expiry Time: (use default value)

VoIP >> SIP Accounts

SIP Account Index No. 1

Profile Name: draytel 1 (11 char max.)

Register via: Auto  Call without Registration

SIP Port: 5060

Domain/Realm: draytel.org (63 char max.)

Proxy: draytel.org (63 char max.)

Act as outbound proxy

Display Name: David (23 char max.)

Account Number/Name: 4321 (63 char max.)

Authentication ID

Password: \*\*\*\* (63 char max.)

Expiry Time: 1 hour 3600 sec

NAT Traversal Support: None

Ring Port:  Phone1  Phone2  ISDN1-S0 Any  ISDN2-TE

Ring Pattern: 1

OK Cancel

**David calls John**

He picks up the phone and dials 2222# (DialPlan Phone Number for John) Or,  
He picks up the phone and dials 1234# (John's Account Name)

**CODEC/RTP/DTMF---**

(Use default value)

## 5.5.2 Peer-to-Peer Calling

Example 3: Arnor and Paulin have Vigor routers respectively, they can call each other *without* SIP Registrar. First they must have each other's IP address and assign an Account Name for the port used for calling.

Arnor's SIP URL: 1234@214.61.172.53      Paulin's SIP URL: 4321@ 203.69.175.24

### Settings for Arnor

DialPlan index 1  
 Phone Number: 1111  
 Display Name: paulin  
 SIP URL: 4321@ 203.69.175.24

### SIP Accounts Settings ---

Profile Name: Paulin  
 Register via: None  
 SIP Port: 5060(default)  
 Domain/Realm: (blank)  
 Proxy: (blank)  
 Act as outbound proxy: unchecked  
 Display Name: Arnor  
 Account Name: 1234  
 Authentication ID: unchecked  
 Password: (blank)  
 Expiry Time: (use default value)

### CODEC/RTP/DTMF---

(Use default value)

### Settings for Paulin

DialPlan index 1  
 Phone Number:2222  
 Display Name: Arnor  
 SIP URL: 1234@214.61.172.53

### SIP Accounts Settings ---

Profile Name: Arnor  
 Register via: None  
 SIP Port: 5060(default)  
 Domain/Realm: (blank)  
 Proxy: (blank)  
 Act as outbound proxy: unchecked  
 Display Name: Paulin  
 Account Name: 4321  
 Authentication ID: unchecked  
 Password: (blank)  
 Expiry Time: (use default value)

### CODEC/RTP/DTMF---

(Use default value)

Phone Book Index No. 1

Enable

Phone Number: 1111

Display Name: paulin

SIP URL: 4321@ 203.69.175.24

Loop through: None

Backup Phone Number:

OK Clear Cancel

VoIP >> SIP Accounts

SIP Account Index No. 1

Profile Name: Paulin (11 char max.)

Register via: None  Call without Registration

SIP Port: 5060

Domain/Realm: (63 char max.)

Proxy: (63 char max.)

Act as outbound proxy

Display Name: Arnor (23 char max.)

Account Number/Name: 1234 (63 char max.)

Authentication ID (63 char max.)

Password: (63 char max.)

Expiry Time: 1 hour 3600 sec

NAT Traversal Support: None

Ring Port:  Phone1  Phone2  ISDN1-S0 Any  ISDN2-TE

Ring Pattern: 1

OK Cancel

### Arnor calls Paulin

He picks up the phone and dials 1111#. (DialPlan Phone Number for Arnor)

Phone Book Index No. 1

Enable

Phone Number: 2222

Display Name: Arnor

SIP URL: 1234@ 214.61.172.53

Loop through: None

Backup Phone Number:

OK Clear Cancel

VoIP >> SIP Accounts

SIP Account Index No. 1

Profile Name: Arnor (11 char max.)

Register via: None  Call without Registration

SIP Port: 5060

Domain/Realm: (63 char max.)

Proxy: (63 char max.)

Act as outbound proxy

Display Name: Paulin (23 char max.)

Account Number/Name: 4321 (63 char max.)

Authentication ID (63 char max.)

Password: (63 char max.)

Expiry Time: 1 hour 3600 sec

NAT Traversal Support: None

Ring Port:  Phone1  Phone2  ISDN1-S0 Any  ISDN2-TE

Ring Pattern: 1

OK Cancel

### Paulin calls Arnor

He picks up the phone and dials 2222# (DialPlan Phone Number for John)



## 5.6 Upgrade Firmware for Your Router

Before upgrading your router firmware, you need to install the Router Tools. The **Firmware Upgrade Utility** is included in the tools.

1. Insert CD of the router to your CD ROM.
2. From the webpage, please find out **Utility** menu and click it.
3. On the webpage of Utility, click **Install Now!** (under Syslog description) to install the corresponding program.

Please remember to set as follows in your DrayTek Router :

- Server IP Address : IP address of the PC that runs the Syslog
- Port Number : Default value 514



4. The file **RTSxxx.exe** will be asked to copy onto your computer. Remember the place of storing the execution file.
5. Go to **www.draytek.com** to find out the newly update firmware for your router.
6. Access into **Support Center >> Downloads**. Find out the model name of the router and click the firmware link. The Tools of Vigor router will display as shown below.

Tools Name	Released Date	Version	OS	Support Model	Download
Router Tools	21/12/2006	3.5.1	MS-Windows	All Model	<a href="#">zip</a>
Smart VPN Client	18/08/2006	3.2.6	MS-Windows	All Model	<a href="#">zip</a>
LPR	27/06/2005	1.0	MS-Windows	For Print Function	<a href="#">zip</a>
VTA	15/09/2005	2.8	Windows2000/XP	For ISDN Model	<a href="#">zip</a>
DialPlan	26/01/2006	2.5_lite	MS-Windows	For VoIP Model	<a href="#">zip</a>

7. Choose the one that matches with your operating system and click the corresponding link to download correct firmware (zip file).
8. Next, decompress the zip file.

9. Double click on the icon of router tool. The setup wizard will appear.

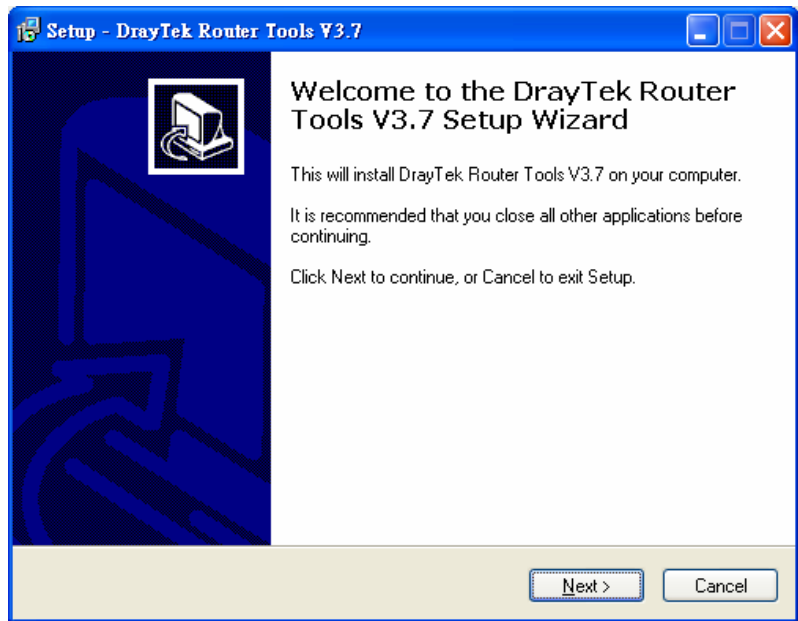

10. Follow the onscreen instructions to install the tool. Finally, click **Finish** to end the installation.
11. From the **Start** menu, open **Programs** and choose **Router Tools XXX >> Firmware Upgrade Utility**.

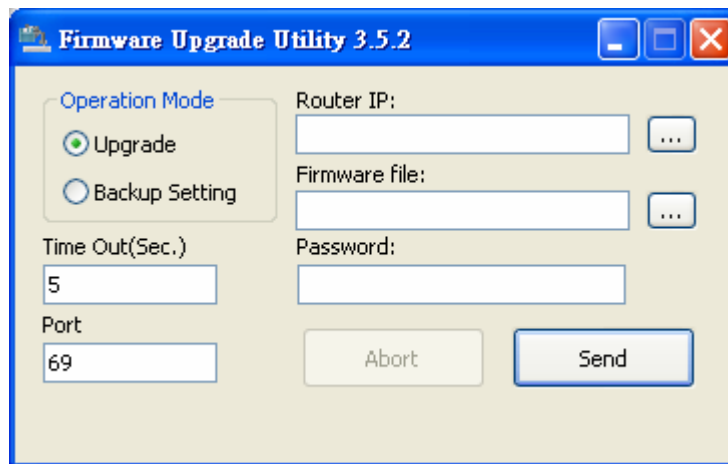

12. Type in your router IP, usually **192.168.1.1**.
13. Click the button to the right side of Firmware file typing box. Locate the files that you download from the company web sites. You will find out two files with different extension names, **xxxx.all** (keep the old custom settings) and **xxxx.rst** (reset all the custom settings to default settings). Choose any one of them that you need.

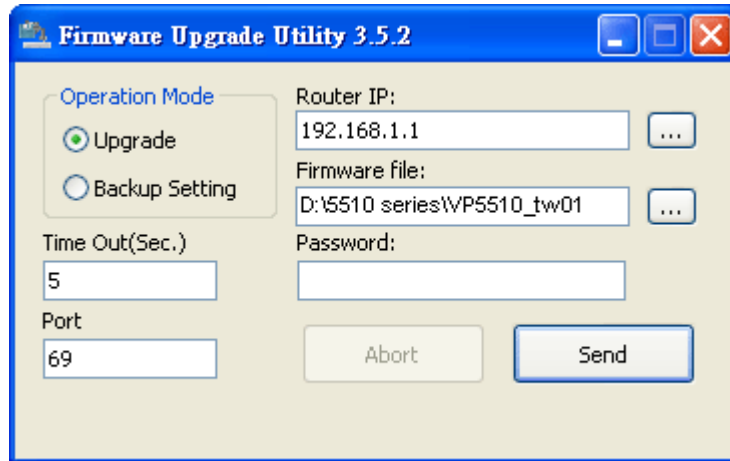

14. Click **Send**.

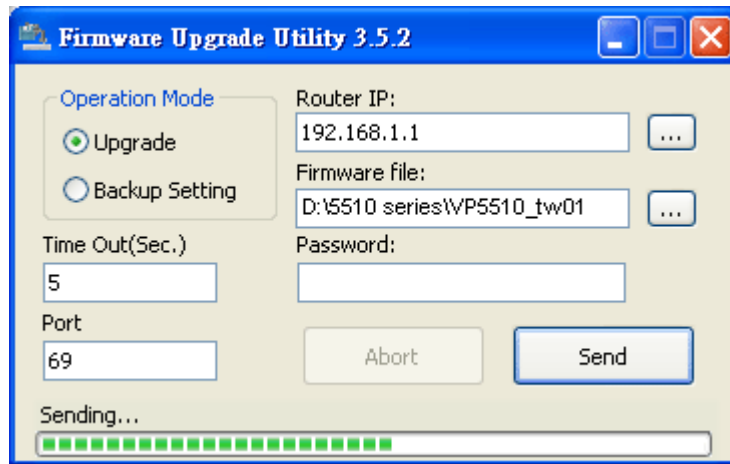

15. Now the firmware update is finished.

## 5.7 Request a certificate from a CA server on Windows CA Server

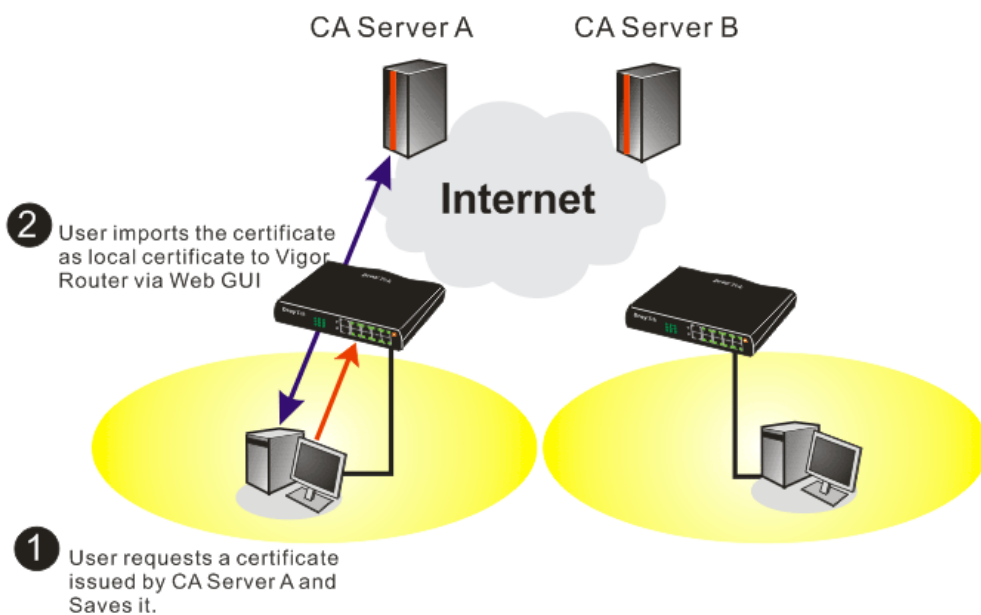

1. Go to **Certificate Management** and choose **Local Certificate**.

Certificate Management >> Local Certificate

**X509 Local Certificate Configuration**

Name	Subject	Status	Modify
Local	---	---	<input type="button" value="View"/> <input type="button" value="Delete"/>

**X509 Local Certificate**

2. You can click **GENERATE** button to start to edit a certificate request. Enter the information in the certificate request.

Certificate Management >> Local Certificate

**Generate Certificate Request**

**Subject Alternative Name**

Type:    
 Domain Name:

---

**Subject Name**

Country (C):   
 State (ST):   
 Location (L):   
 Organization (O):   
 Organization Unit (OU):   
 Common Name (CN):   
 Email (E):

---

Key Type:   
 Key Size:

3. Copy and save the X509 Local Certificate Request as a text file and save it for later use.

Certificate Management >> Local Certificate

**X509 Local Certificate Configuration**

Name	Subject	Status	Modify
Local	/C=TW/O=Draytek/emailAddress...	Requesting	<input type="button" value="View"/> <input type="button" value="Delete"/>

**X509 Local Certificate Request**

```

-----BEGIN CERTIFICATE REQUEST-----
MIIBjzCB+QIBADBQMqswCQYDVQQGEwJUVzEQMA4GA1UEChMHRHJheXR1azELMAkG
A1UECzMCUkQxIjAgBgkqhkiG9w0BCQEWES3N1cnZpY2VhZmJheXR1ay5jb20wgZSw
DQYJKoZIhvcNAQEBBQADgYOAMIGJAoGBAMemQ68+e0u+fS237c1TP51CRDFuxgxw
K89UJEeq11h7rUYhrfgFj07kZ0fQTpWjqu/wv3vmwOEnkg16mntzq9tBmDF12djG
cdIZQh7H9MOmpP0qrPu0cgA0Ete1oaLhgV1MovrojR6OXNPABq6kYr4NYLHh1bFH
MDkjEpdMQARpAgMBAAAGgADANBgkqhkiG9w0BAQUFAAOBgQBWphus100n9rZ8y2C2
egi0n39FoAPathPmqHZoAYFGeDMCHGUY4vHdkQo7RObVtKkqs17D12hPHESHgS0
P/D4zKQiJLTXSm8+3gX3ZdRq+IjpruzZTTBPBMR93PhP3USUYTrBL01pNVQCGqb
jaquLF4Zpb0VVqOq8a4UbtXENw==
-----END CERTIFICATE REQUEST-----

```

4. Connect to CA server via web browser. Follow the instruction to submit the request. Below we take a Windows 2000 CA server for example. Select **Request a Certificate**.

The screenshot shows the 'Microsoft Certificate Services' website. The page title is 'Microsoft Certificate Services -- vigor' and there is a 'Home' link in the top right. The main heading is 'Welcome'. Below the heading, there is a paragraph explaining the site's purpose: 'You use this web site to request a certificate for your web browser, e-mail client, or other secure program. Once you acquire a certificate, you will be able to securely identify yourself to other people over the web, sign your e-mail messages, encrypt your e-mail messages, and more depending upon the type of certificate you request.' Underneath, there is a section titled 'Select a task:' with three radio button options: 'Retrieve the CA certificate or certificate revocation list', 'Request a certificate' (which is selected), and 'Check on a pending certificate'. A 'Next >' button is located at the bottom right of the page.

Select **Advanced request**.

The screenshot shows the 'Microsoft Certificate Services' website. The page title is 'Microsoft Certificate Services -- vigor' and there is a 'Home' link in the top right. The main heading is 'Choose Request Type'. Below the heading, there is a paragraph: 'Please select the type of request you would like to make:'. There are two radio button options: 'User certificate request' and 'Advanced request' (which is selected). Under the 'User certificate request' option, there is a small rectangular box with the text 'User Certificate' inside. A 'Next >' button is located at the bottom right of the page.

Select **Submit a certificate request a base64 encoded PKCS #10 file or a renewal request using a base64 encoded PKCS #7 file**

The screenshot shows the 'Microsoft Certificate Services' website. The page title is 'Microsoft Certificate Services -- vigor' and there is a 'Home' link in the top right. The main heading is 'Advanced Certificate Requests'. Below the heading, there is a paragraph: 'You can request a certificate for yourself, another user, or a computer using one of the following methods. Note that the policy of the certification authority (CA) will determine the certificates that you can obtain.' There are three radio button options: 'Submit a certificate request to this CA using a form.', 'Submit a certificate request using a base64 encoded PKCS #10 file or a renewal request using a base64 encoded PKCS #7 file.' (which is selected), and 'Request a certificate for a smart card on behalf of another user using the Smart Card Enrollment Station. You must have an enrollment agent certificate to submit a request for another user.' A 'Next >' button is located at the bottom right of the page.

Import the X509 Local Certificate Request text file. Select **Router (Offline request)** or **IPSec (Offline request)** below.

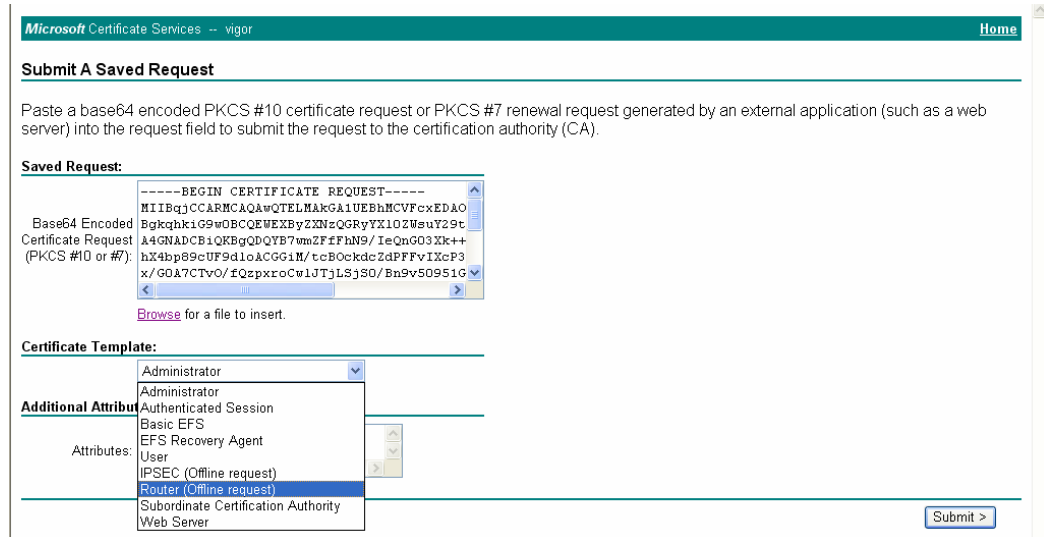

Then you have done the request and the server now issues you a certificate. Select **Base 64 encoded** certificate and **Download CA certificate**. Now you should get a certificate (.cer file) and save it.

- Back to Vigor router, go to **Local Certificate**. Click **IMPORT** button and browse the file to import the certificate (.cer file) into Vigor router. When finished, click refresh and you will find the below window showing “-----BEGIN CERTIFICATE-----.....”  
**Certificate Management >> Local Certificate**

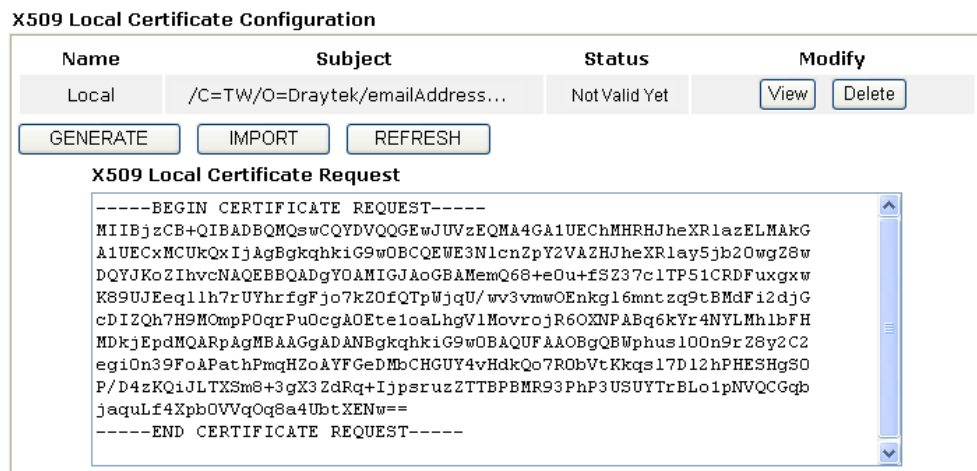

- You may review the detail information of the certificate by clicking **View** button.

Name :	Local
Issuer :	/C=US/CN=vigor
Subject :	/emailAddress=press@draytek.com/C=TW/O=Draytek
Subject Alternative Name :	DNS: draytek.com
Valid From :	Aug 30 23:08:43 2005 GMT
Valid To :	Aug 30 23:17:47 2007 GMT

## 5.8 Request a CA Certificate and Set as Trusted on Windows CA Server

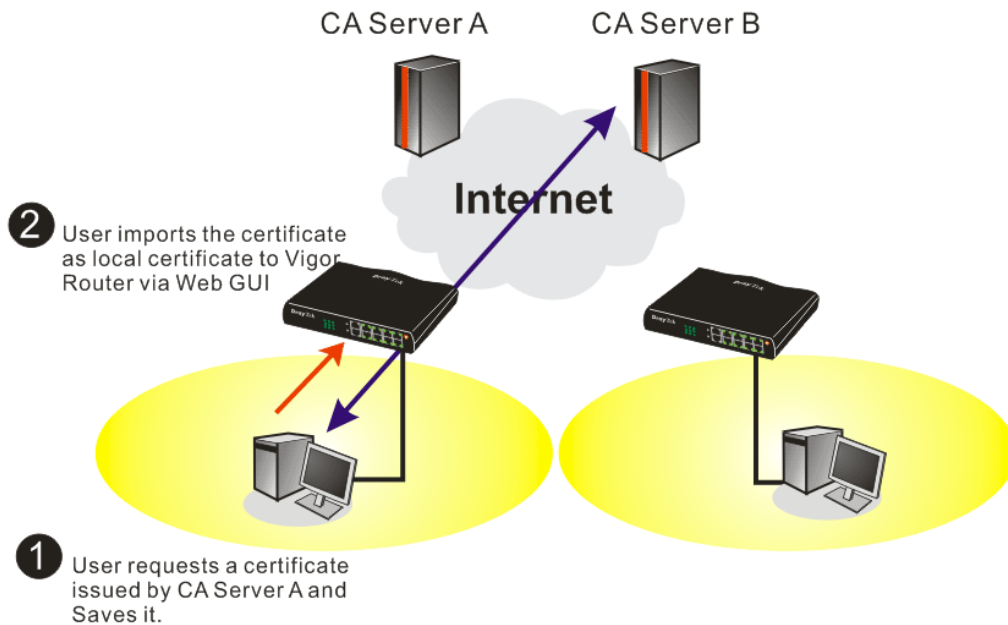

1. Use web browser connecting to the CA server that you would like to retrieve its CA certificate. Click **Retrieve the CA certificate or certificate recoring list**.

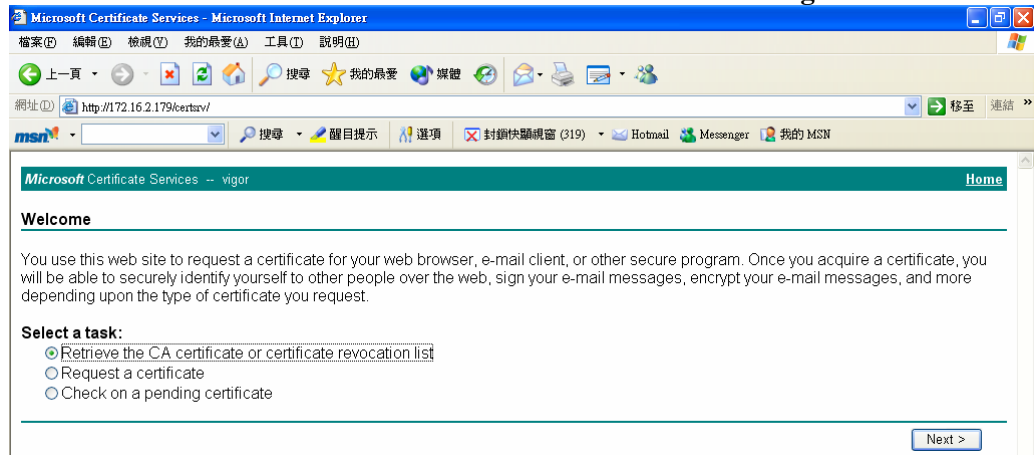

- In **Choose file to download**, click CA Certificate **Current** and **Base 64 encoded**, and **Download CA certificate** to save the .cer. file.

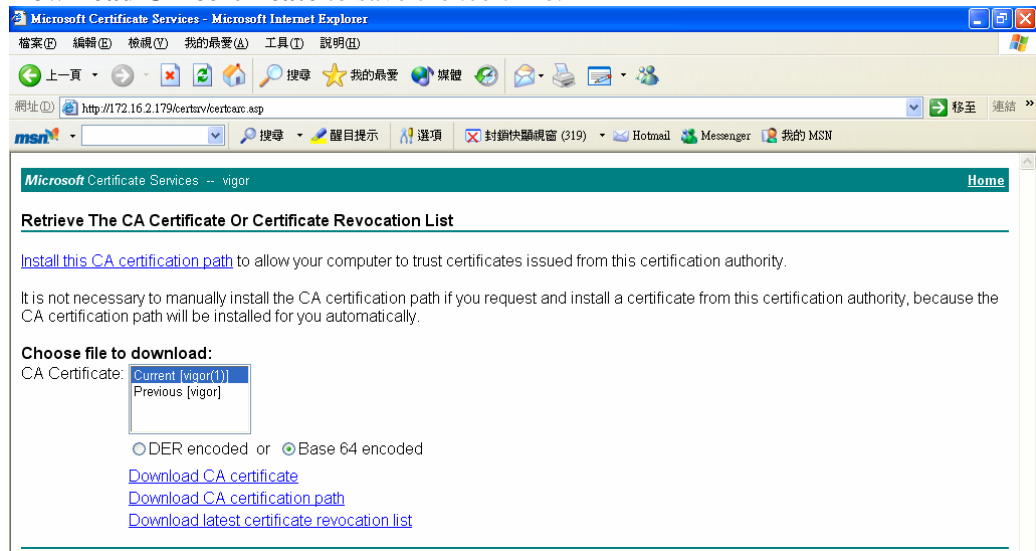

- Back to Vigor router, go to **Trusted CA Certificate**. Click **IMPORT** button and browse the file to import the certificate (.cer file) into Vigor router. When finished, click refresh and you will find the below illustration.

Certificate Management >> Trusted CA Certificate

#### X509 Trusted CA Certificate Configuration

Name	Subject	Status	Modify	
Trusted CA-1	---	---	View	Delete
Trusted CA-2	---	---	View	Delete
Trusted CA-3	---	---	View	Delete

IMPORT REFRESH

- You may review the detail information of the certificate by clicking **View** button.

Name :	Trusted CA-1
Issuer :	/C=US/CN=vigor
Subject :	/C=US/CN=vigor
Subject Alternative Name :	DNS:draytek.com
Valid From :	Aug 30 23:08:43 2005 GMT
Valid To :	Aug 30 23:17:47 2007 GMT

Close

**Note:** Before setting certificate configuration, please go to **System Maintenance >> Time and Date** to reset current time of the router first.



# 6

## Trouble Shooting

This section will guide you to solve abnormal situations if you cannot access into the Internet after installing the router and finishing the web configuration. Please follow sections below to check your basic installation status stage by stage.

- Checking if the hardware status is OK or not.
- Checking if the network connection settings on your computer are OK or not.
- Pinging the router from your computer.
- Checking if the ISP settings are OK or not.
- Backing to factory default setting if necessary.

If all above stages are done and the router still cannot run normally, it is the time for you to contact your dealer for advanced help.

### 6.1 Checking If the Hardware Status Is OK or Not

Follow the steps below to verify the hardware status.

1. Check the power line and WLAN/LAN cable connections. Refer to “**1.3 Hardware Installation**” for details.
2. Turn on the router. Make sure the **ACT LED** blink once per second and the correspondent **LAN LED** is bright.



3. If not, it means that there is something wrong with the hardware status. Simply back to “**1.3 Hardware Installation**” to execute the hardware installation again. And then, try again.

### 6.2 Checking If the Network Connection Settings on Your Computer Is OK or Not

Sometimes the link failure occurs due to the wrong network connection settings. After trying the above section, if the link is still failed, please do the steps listed below to make sure the network connection settings is OK.

## For Windows



The example is based on Windows XP. As to the examples for other operation systems, please refer to the similar steps or find support notes in [www.draytek.com](http://www.draytek.com).

1. Go to Control Panel and then double-click on Network Connections.



2. Right-click on Local Area Connection and click on Properties.

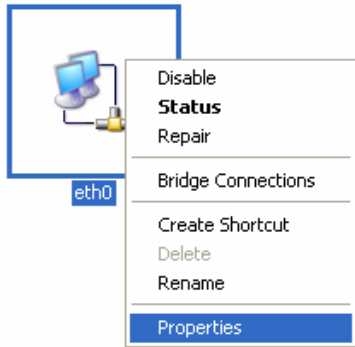

3. Select Internet Protocol (TCP/IP) and then click Properties.

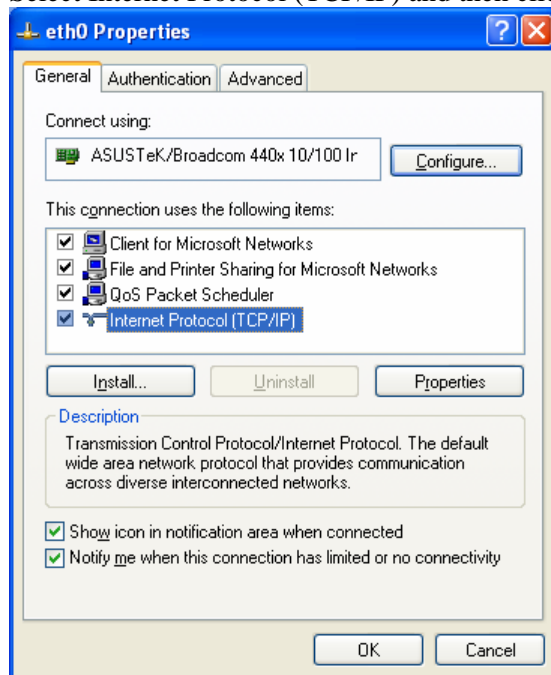

4. Select Obtain an IP address automatically and Obtain DNS server address automatically.

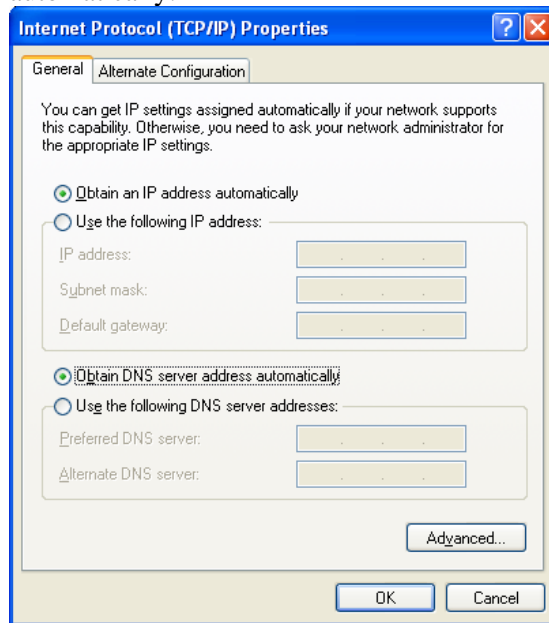

### For MacOs

1. Double click on the current used MacOs on the desktop.
2. Open the **Application** folder and get into **Network**.
3. On the **Network** screen, select **Using DHCP** from the drop down list of Configure IPv4.

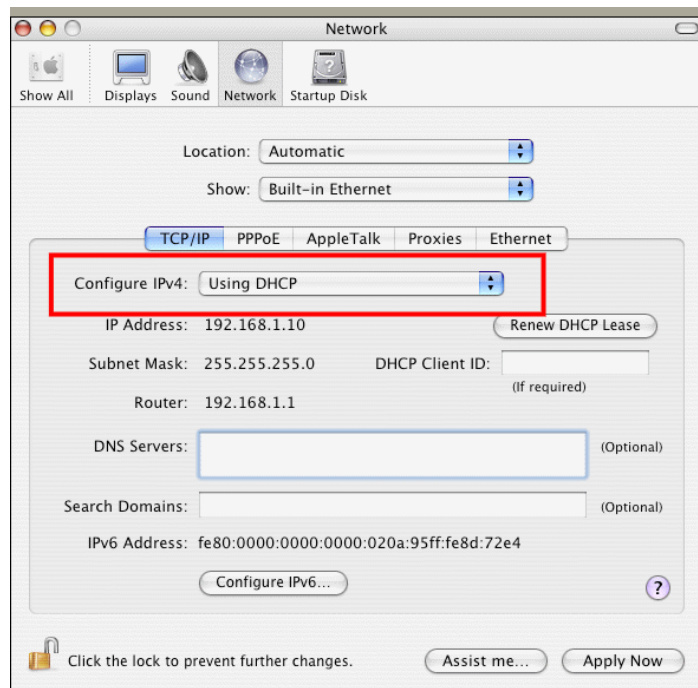

## 6.3 Pinging the Router from Your Computer

The default gateway IP address of the router is 192.168.1.1. For some reason, you might need to use “ping” command to check the link status of the router. **The most important thing is that the computer will receive a reply from 192.168.1.1.** If not, please check the IP address of your computer. We suggest you setting the network connection as **get IP automatically**. (Please refer to the section 4.2)

Please follow the steps below to ping the router correctly.

### For Windows

1. Open the **Command Prompt** window (from **Start menu**> **Run**).
2. Type **command** (for Windows 95/98/ME) or **cmd** (for Windows NT/ 2000/XP). The DOS command dialog will appear.

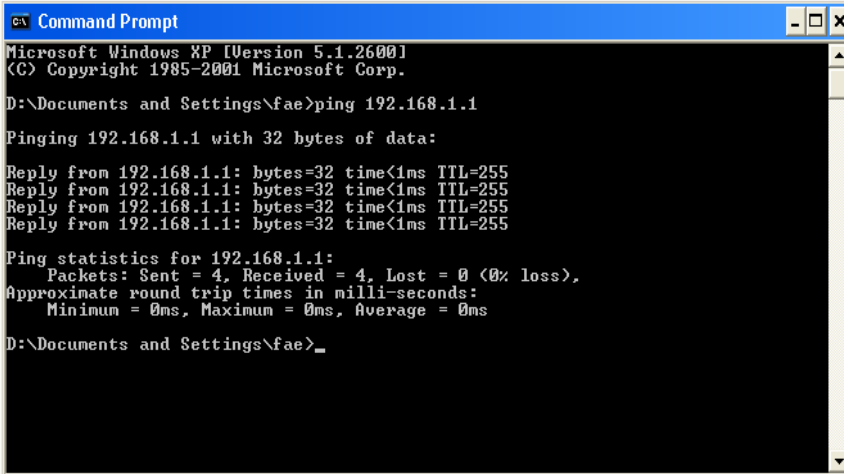

```
Microsoft Windows XP [Version 5.1.2600]
(C) Copyright 1985-2001 Microsoft Corp.

D:\Documents and Settings\fae>ping 192.168.1.1

Pinging 192.168.1.1 with 32 bytes of data:

Reply from 192.168.1.1: bytes=32 time<1ms TTL=255
Reply from 192.168.1.1: bytes=32 time<1ms TTL=255
Reply from 192.168.1.1: bytes=32 time<1ms TTL=255
Reply from 192.168.1.1: bytes=32 time<1ms TTL=255

Ping statistics for 192.168.1.1:
    Packets: Sent = 4, Received = 4, Lost = 0 (0% loss),
    Approximate round trip times in milli-seconds:
        Minimum = 0ms, Maximum = 0ms, Average = 0ms

D:\Documents and Settings\fae>_
```

3. Type **ping 192.168.1.1** and press [Enter]. If the link is OK, the line of **“Reply from 192.168.1.1:bytes=32 time<1ms TTL=255”** will appear.
4. If the line does not appear, please check the IP address setting of your computer.

### For MacOs (Terminal)

1. Double click on the current used MacOs on the desktop.
2. Open the **Application** folder and get into **Utilities**.
3. Double click **Terminal**. The Terminal window will appear.
4. Type **ping 192.168.1.1** and press [Enter]. If the link is OK, the line of **“64 bytes from 192.168.1.1: icmp\_seq=0 ttl=255 time=xxxx ms”** will appear.

```

Terminal — bash — 80x24
Last login: Sat Jan  3 02:24:18 on ttys1
Welcome to Darwin!
Vigor10:~ draytek$ ping 192.168.1.1
PING 192.168.1.1 (192.168.1.1): 56 data bytes
64 bytes from 192.168.1.1: icmp_seq=0 ttl=255 time=0.755 ms
64 bytes from 192.168.1.1: icmp_seq=1 ttl=255 time=0.697 ms
64 bytes from 192.168.1.1: icmp_seq=2 ttl=255 time=0.716 ms
64 bytes from 192.168.1.1: icmp_seq=3 ttl=255 time=0.731 ms
64 bytes from 192.168.1.1: icmp_seq=4 ttl=255 time=0.72 ms
^C
--- 192.168.1.1 ping statistics ---
5 packets transmitted, 5 packets received, 0% packet loss
round-trip min/avg/max = 0.697/0.723/0.755 ms
Vigor10:~ draytek$

```

## 6.4 Checking If the ISP Settings are OK or Not

Click **WAN>> Internet Access** and then check whether the ISP settings are set correctly. Click **Details Page** of WAN1/WAN2 to review the settings that you configured previously.

WAN >> Internet Access

### Internet Access

Index	Display Name	Physical Mode	Access Mode	
WAN1		Ethernet	Static or Dynamic IP	<a href="#">Details Page</a>
WAN2		Ethernet	None	<a href="#">Details Page</a>

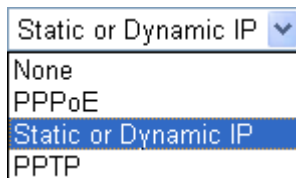

### For PPPoE Users

1. Check if the **Enable** option is selected.
2. Check if **Username** and **Password** are entered with correct values that you **got from** your **ISP**.

**WAN 1**

<p><b>PPPoE Client Mode</b></p> <p><input checked="" type="radio"/> Enable <input type="radio"/> Disable</p> <hr/> <p><b>ISP Access Setup</b></p> <p>Username <input type="text" value="admin"/></p> <p>Password <input type="password" value="*****"/></p> <p>Index(1-15) in <b>Schedule</b> Setup: =&gt; <input type="text"/> , <input type="text"/> , <input type="text"/> , <input type="text"/></p> <p><b>ISDN Dial Backup Setup</b></p> <p>Dial Backup Mode <input type="text" value="None"/></p>	<p><b>PPP/MP Setup</b></p> <p>PPP Authentication <input type="text" value="PAP or CHAP"/></p> <p>Idle Timeout <input type="text" value="-1"/> second(s)</p> <p><b>IP Address Assignment Method (IPCP)</b> <input type="text" value="WAN IP Alias"/></p> <p>Fixed IP: <input type="radio"/> Yes <input checked="" type="radio"/> No (Dynamic IP)</p> <p>Fixed IP Address <input type="text"/></p> <hr/> <p><input checked="" type="radio"/> Default MAC Address  <input type="radio"/> Specify a MAC Address</p> <p>MAC Address:  <input type="text" value="00"/> <input type="text" value=".50"/> <input type="text" value=".7F"/> <input type="text" value=".22"/> <input type="text" value=".33"/> <input type="text" value=".45"/></p>
---	---

### For Static/Dynamic IP Users

1. Check if the **Enable** option is selected.
2. Check if **IP address, Subnet Mask and Gateway** are entered with correct values that you **got from your ISP**.

**WAN 1**

<p><b>Static or Dynamic IP (DHCP Client)</b></p> <p><input checked="" type="radio"/> Enable <input type="radio"/> Disable</p> <hr/> <p><b>Keep WAN Connection</b></p> <p><input type="checkbox"/> Enable PING to keep alive</p> <p>PING to the IP <input type="text"/></p> <p>PING Interval <input type="text" value="0"/> minute(s)</p> <hr/> <p><b>WAN Connection Detection</b></p> <p>Mode <input type="text" value="ARP Detect"/></p> <p>Ping IP <input type="text"/></p> <p>TTL:</p> <hr/> <p><b>RIP Protocol</b></p> <p><input type="checkbox"/> Enable RIP</p>	<p><b>WAN IP Network Settings</b> <input type="text" value="WAN IP Alias"/></p> <p><input type="radio"/> Obtain an IP address automatically</p> <p>Router Name <input type="text"/> *</p> <p>Domain Name <input type="text"/> *</p> <p>* : Required for some ISPs</p> <p><input checked="" type="radio"/> Specify an IP address</p> <p>IP Address <input type="text" value="172.16.3.229"/></p> <p>Subnet Mask <input type="text" value="255.255.0.0"/></p> <p>Gateway IP Address <input type="text" value="172.16.3.4"/></p> <hr/> <p><input checked="" type="radio"/> Default MAC Address  <input type="radio"/> Specify a MAC Address</p> <p>MAC Address:  <input type="text" value="00"/> <input type="text" value=".50"/> <input type="text" value=".7F"/> <input type="text" value=".22"/> <input type="text" value=".33"/> <input type="text" value=".45"/></p> <hr/> <p><b>DNS Server IP Address</b></p> <p>Primary IP Address <input type="text"/></p> <p>Secondary IP Address <input type="text"/></p>
---	--

## For PPTP Users

1. Check if the **Enable** option for **PPTP Link** is selected.

WAN >> Internet Access

WAN 1

<b>PPTP Client Mode</b> <input checked="" type="radio"/> Enable <input type="radio"/> Disable PPTP Server <input type="text" value="10.0.0.138"/>	<b>PPP Setup</b> PPP Authentication <input type="text" value="PAP or CHAP"/> Idle Timeout <input type="text" value="-1"/> second(s)
<b>ISP Access Setup</b> Username <input type="text"/> Password <input type="text"/> Index(1-15) in <b>Schedule</b> Setup: => <input type="text"/> , <input type="text"/> , <input type="text"/> , <input type="text"/>	<b>IP Address Assignment Method (IPCP)</b> <input type="text" value="WAN IP Alias"/> Fixed IP: <input type="radio"/> Yes <input checked="" type="radio"/> No (Dynamic IP) Fixed IP Address <input type="text"/>
<b>ISDN Dial Backup Setup</b> Dial Backup Mode <input type="text" value="None"/>	<b>WAN IP Network Settings</b> <input type="radio"/> Obtain an IP address automatically <input checked="" type="radio"/> Specify an IP address IP Address <input type="text" value="10.0.0.150"/> Subnet Mask <input type="text" value="255.0.0.0"/>

OK Cancel

2. Check if **PPTP Server**, **Username**, **Password** and **WAN IP address** are set correctly (must identify with the values from your ISP).

## 6.5 Backing to Factory Default Setting If Necessary

Sometimes, a wrong connection can be improved by returning to the default settings. Try to reset the router by software or hardware.



**Warning:** After pressing **factory default setting**, you will lose all settings you did before. Make sure you have recorded all useful settings before you pressing. The password of factory default is null.

### Software Reset

You can reset the router to factory default via Web page.

Go to **System Maintenance** and choose **Reboot System** on the web page. The following screen will appear. Choose **Using factory default configuration** and click **OK**. After few seconds, the router will return all the settings to the factory settings.

System Maintenance >> Reboot System

Reboot System

Do You want to reboot your router ?

Using current configuration  
 Using factory default configuration

OK

## Hardware Reset

While the router is running (ACT LED blinking), press the **Factory Reset** button and hold for more than 5 seconds. When you see the **ACT LED** blinks rapidly, please release the button. Then, the router will restart with the default configuration.

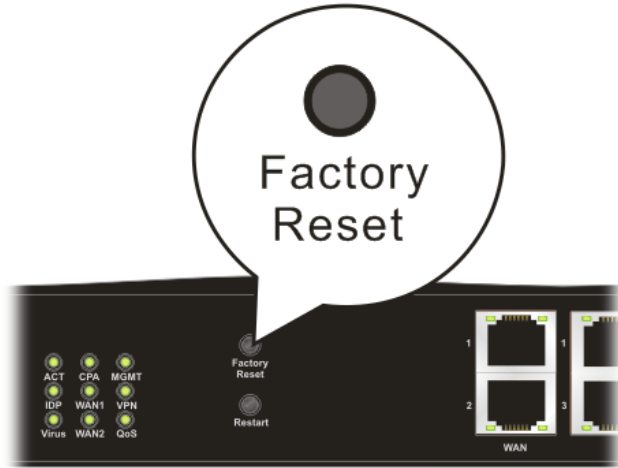

After restore the factory default setting, you can configure the settings for the router again to fit your personal request.

## 6.6 Contacting Your Dealer

If the router still cannot work correctly after trying many efforts, please contact your dealer for further help right away. For any questions, please feel free to send e-mail to [support@draytek.com](mailto:support@draytek.com).