

LinkPlay Wireless Smart Audio Module (A31)

User Manual

Rev 1.0

SEP. 21, 2015

Doc Title	Wireless smart audio module	Number	WMB20150921
		Version	1.0

HISTORY

Version	Date	Description	Author
0.1	09/21/2015	Initial document	

Confidential

Doc Title	Wireless smart audio module	Number	WMB20150921
		Version	1.0

INDEX

Features	4
1 . Overview	5
1.1. Parameters.....	5
2. Hardware Description	6
2.1. Description of hardware interface.....	6
2.2. Mechanical dimension	8
2.3. Connect with Audio Codec	9
2.4. External antenna	11
2.5. 10/100M Ethernet Port	11
2.5.1. Connect the module with RJ45	12
2.6. USB host port	12
2.7. Power supply	13
2.8. Silkscreen and Package.....	13
3. Software	14
3.1. Airplay introduction.....	15
3.2. DLNA introduction	15
3.3. WiFi mode	15
3.3.1. AP Client mode.....	16
3.4. Web Server setup	16
3.4.1. Web server login	17
3.4.2. Connecting the module to another AP	17
3.4.3. Advanced setting for the module	18
3.4.3.1. Module setting page	18
3.4.3.1.1. Software upgrade	18
3.5. Use UART to debug.....	19
3.6. WPS Setting.....	20
3.7. Restore to factory setting	20

Doc Title	Wireless smart audio module	Number	WMB20150921
		Version	1.0

Features

- Support 2.4GHz 802.11 b/g/n with highly optimized Wi-Fi performance
- Support 10/100Mbps Ethernet
- Support Internet audio streaming via Apple AirPlay or DLNA
- Support Spotify, Pandora, iHeartRadio, Tidal, Tune in and many more ...
- Support TCP/IP/UDP/HTTP/UPNP protocol
- Support play-list with M3U, M3U8, WPL, ASX, PLS formats
- Support MP3/WMA/AAC/AAC+/ALAC/FLAC/APE/WAV etc. audio formats
- Support STA/AP/AP Client mode
- Support Ethernet, UART and USB2.0 interfaces
- Support digital audio input and output via I2S interface
- Built-in web server to easily configure the module
- Support remote control of module via WLAN
- Support online firmware upgrade
- Support module configuration via iOS or Android APP
- Support Wi-Fi UART pass-through or self-defined MCU/UART interface
- Support multi-room audio (a.k.a, party mode) and multi-channel audio with perfect time synchronization among speakers
- Support most popular streaming services around the world
- Provide iOS, Android and PC SDK and applications to work with the module

Applications

- Wi-Fi speaker
- Smart toy
- Smart audio receiver
- Wi-Fi audio docking station for smartphones
- Internet smart audio device
- Internet radio receiver
- Home automation and Internet of Thing (IoT)

Doc Title	Wireless smart audio module	Number	WMB20150921
		Version	1.0

1. Overview

LinkPlay Wi-Fi Audio module A31-2, is our second generation smart audio modules developed to be used in wireless speaker, wireless docking station, Wi-Fi base station, home automation and smart toy. It supports 802.11b/g/n standard with up to 300Mbps bandwidth. It could work at AP, AP client or station modes. It is fully compatible with Apple AirPlay and digital living network alliance (DLNA) streaming standards. It supports Hi-Fi audio up to 192KHz, 24-bit with most popular audio formats. It supports multi-room and multi-channel audio streaming with perfect synchronization.

With this module, you can play the music on your speaker wirelessly from iPhone, iPad , iPod touch, Android devices or PC. More important, it enables the traditional speaker system to become the Internet enabled device through the wired or wireless connection provided by the module. Thus, you could freely playback any Internet audio contents such as music, podcast, radio or either the accompany audio in the movie directly from the Internet.

1.1. Parameters

	Items	Performance
Wireless	Certification	FCC/CE/Reach/RoHS
	Standard	802.11 b/g/n 1T1R
	Frequency	2.412GHz-2.484GHz
	Transmit	802.11b: +17dBm(Max.)
		802.11g: +15dBm(Max.)
		802.11n: +14dBm(Max.)
	Receive sensitivity	802.11b: -76dBm
		802.11g: -67dBm
		802.11n(HT20): < -82dBm(MCS0)
802.11n(HT20): < -64dBm(MCS7)		
Antenna options	External: I-PEX	
Hardware	Work voltage	3.5V ~ 5.5V
	Work current	130 mA ~ 320 mA
	Peak current	320 mA
	Standby current	20 mA
	Work temperature	-5°C - 40°C
	Storage temperature	-40°C - 135°C
	Status LED	AP status, client status, power, WiFi data transfer
	I2S input/output	24 bit, up to 192KHz
	Wi-Fi distance	80m
	IO extension	Ethernet, USB, UART, GPIO, I2C
	Size	28.5mm X 38.7mm X 3mm, 36-pin DIP

Doc Title	Wireless smart audio module	Number	WMB20150921
		Version	1.0

Software	Wi-Fi working mode	AP Client (by default)/AP/STA
	Security	WEP/WPA-PSK/WPA2-PSK/WAPI
	Encryption	WEP64/WEP128/TKIP/AES
	User Configuration	Web browser, Companion APP
	Software update	Web browser or APP
	Online update	Support
	Audio source	U disk, Smartphone/Tablet/PC, online contents
	Applications support	iOS, Android, Win7/8
	Audio streaming protocol	AirPlay
		DLNA, Spotify Connect, QQ music Qplay
	Multi-room audio	Support Airplay, Spotify Connect, DLNA, U Disk attached to WiFi device, BT and Aux-in multi-room transmission

Table1-1 LinkPlay A31-2 module parameters

2. Hardware Description

2.1. Description of hardware interface

A31-2 module provides the option to connect with customer board through its 36-pins DIP . The detail is as follows.

Doc Title	Wireless smart audio module	Number	WMB20150921
		Version	1.0

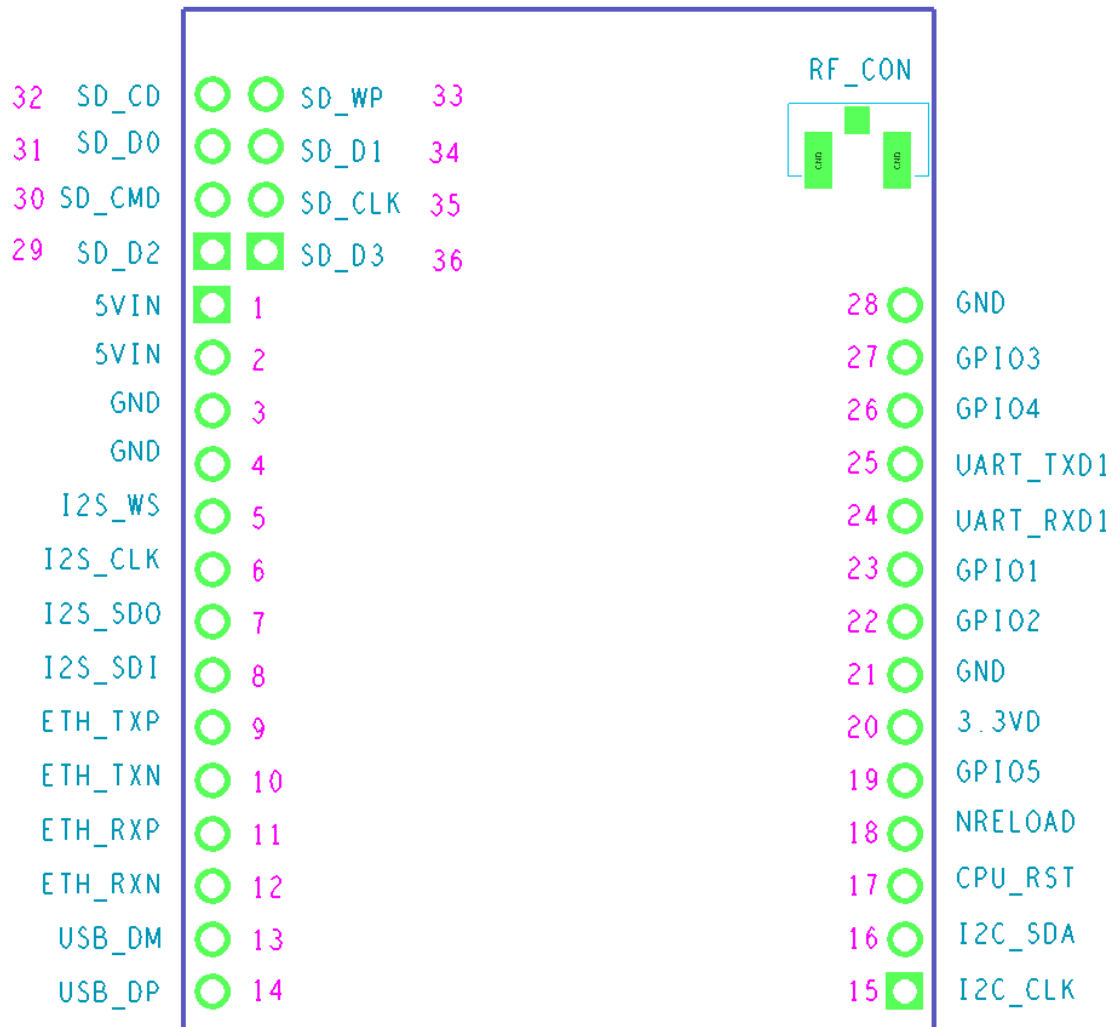

Figure 2-1 A31-2 interface pins

Pin description:

Pin	Description	Net	Type	Comments
3,4,21,28	GND	GND	Power	Ground
1,2	5VD input	DC+5V	Power, I	+5V@ 350mA
20	3.3VD output	DC+3.3V	Power, O	Output +3.3V@100mA
5	I2S_WS	I2S_WS	O	All pins could be pin shared as GPIO
6	I2S_CLK	I2S_CLK	I/O	
7	I2S_SDO	I2S_SDO	O	
8	I2S_SDI	I2S_SDI	I	
9	ETH_TXP	ETH_TXP	O	10M/100M Ethernet interface (Current driven)
10	ETH_TXN	ETH_TXN	O	
11	ETH_RXP	ETH_RXP	I	
12	ETH_RXN	ETH_RXN	I	
13	USB_DM	USB_DM	I/O	USB 2.0 host

Doc Title	Wireless smart audio module	Number	WMB20150921
		Version	1.0

14	USB_DP	USB_DP	I/O	
15	I2C_CLK	I2C_CLK	O	I2C interface, in module 4.7K resistor pull-up
16	I2C_SDA	I2C_SDA	I/O	
17	Module reset	CPU_RST	I,IPU	Reset with pull down, reset time >300ms
18	Restore factory setting	nReload	I/O, IPU	First Input 0 and keep for more than 5 seconds then change to 1, it will go back to factory setting, in module 4.7K resistor pull-up
19	GPIO	GPIO5	I/O, IPU	in module 4.7K resistor pull-up
22	GPIO	GPIO2	I/O, IPU	in module 4.7K resistor pull-up
23	GPIO	GPIO1	I/O, IPU	in module 4.7K resistor pull-up
24	UART receive	UART_RXD	I,	Need keep UART_TXD high during chip boot-up
25	UART transmit	UART_TXD	O, IPU	
26	GPIO	GPIO4	I/O, IPU	
27	GPIO	GPIO3	I/O,IPU	
37	Reference CLK	REF_CLK	O, IPD	Reference Clock Output
29	SDIO Data	SD_D2	I/O	SDIO, GPIO 10K Pull-up
30	SDIO CMD	SD_CMD	O	SDIO CMD, GPIO, 10K IPU
31	SDIO Data	SD_D0	I/O	SDIO Data0, GPIO,10K IPU
32	SDIO Detect	SD_CD	I	SDIO detect, GPIO, 10K IPU
33	SDIO WP	SD_WP	I	Write Protect, GPIO, 10K IPU, If MICRO SD (TF), need put this pin to GND
34	SDIO Data	SD_D1	I/O	SDIO Data 1, GPIO, 10K IPU
35	SDIO CLK	SD_CLK	O	SDIO CLK, GPIO
36	SDIO Data	SD_D3	I/O	SDIO Data 3, GPIO, 10K IPU

Table 2-1 LinkPlay A31-2 module pin description

Notes:

1. I: Input, O: Output, P: Power, IPU: Internal Pull Up, IPD: Internal Pull Down, A: Analog.

2.2. Mechanical dimension

LinkPlay A31-2 module has the physical dimension of 28.5 x 38.7mm. The detailed layout shows below. The unit is in mm.

Doc Title	Wireless smart audio module	Number	WMB20150921
		Version	1.0

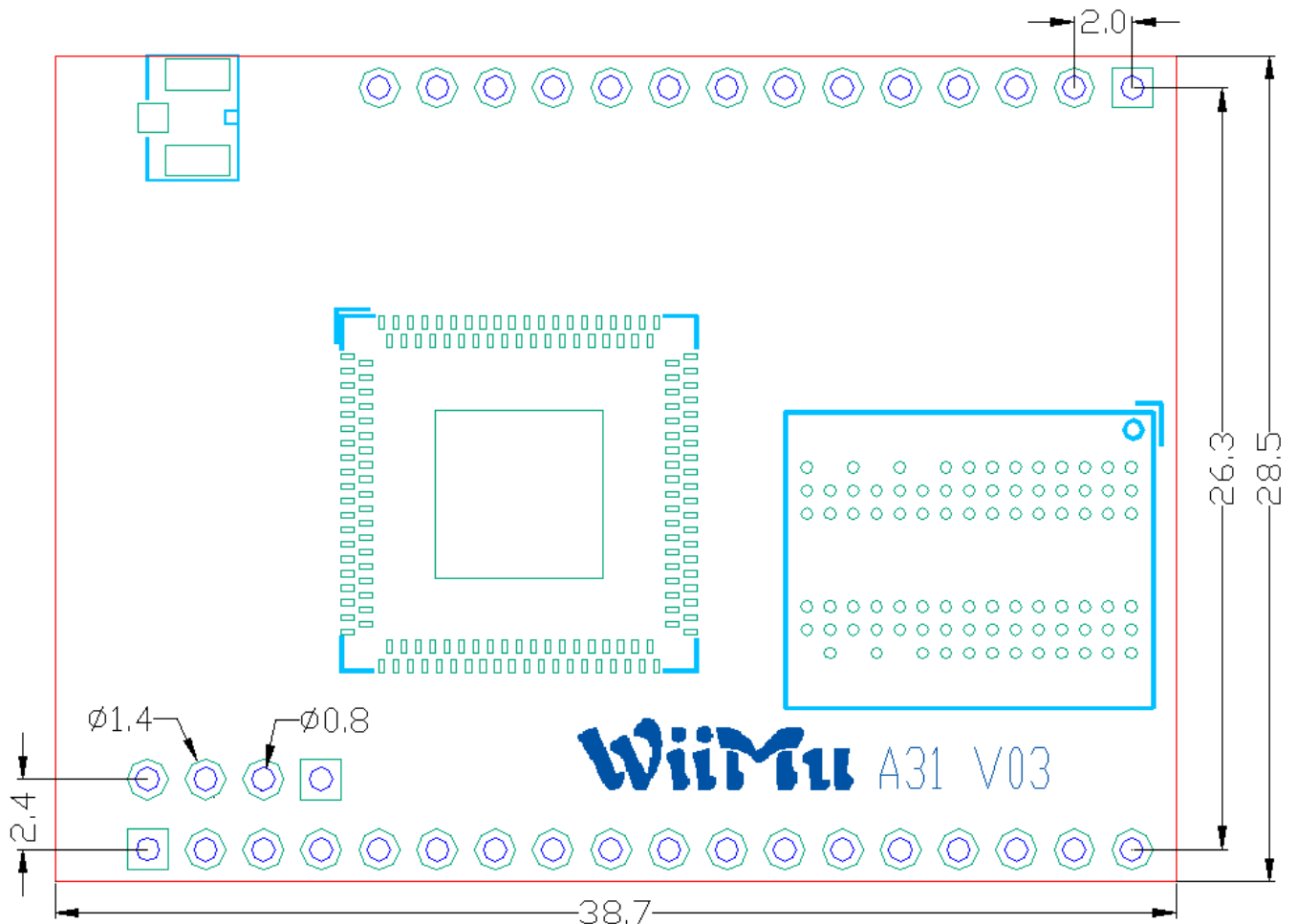

Figure 2-2: LinkPlay A31-2 physical dimension

2.3. Connect with Audio Codec

LinkPlay A31-2 module has digital audio interface I2S. It supports both master and slave modes.

- Master mode:

In master mode, it is recommended to connect with an audio codec IC for audio playback and record shown in the following example. Current module firmware supports Wolfson WM8918/WM8960. The reference schematics is shown below.

Doc Title	Wireless smart audio module	Number	WMB20150921
		Version	1.0

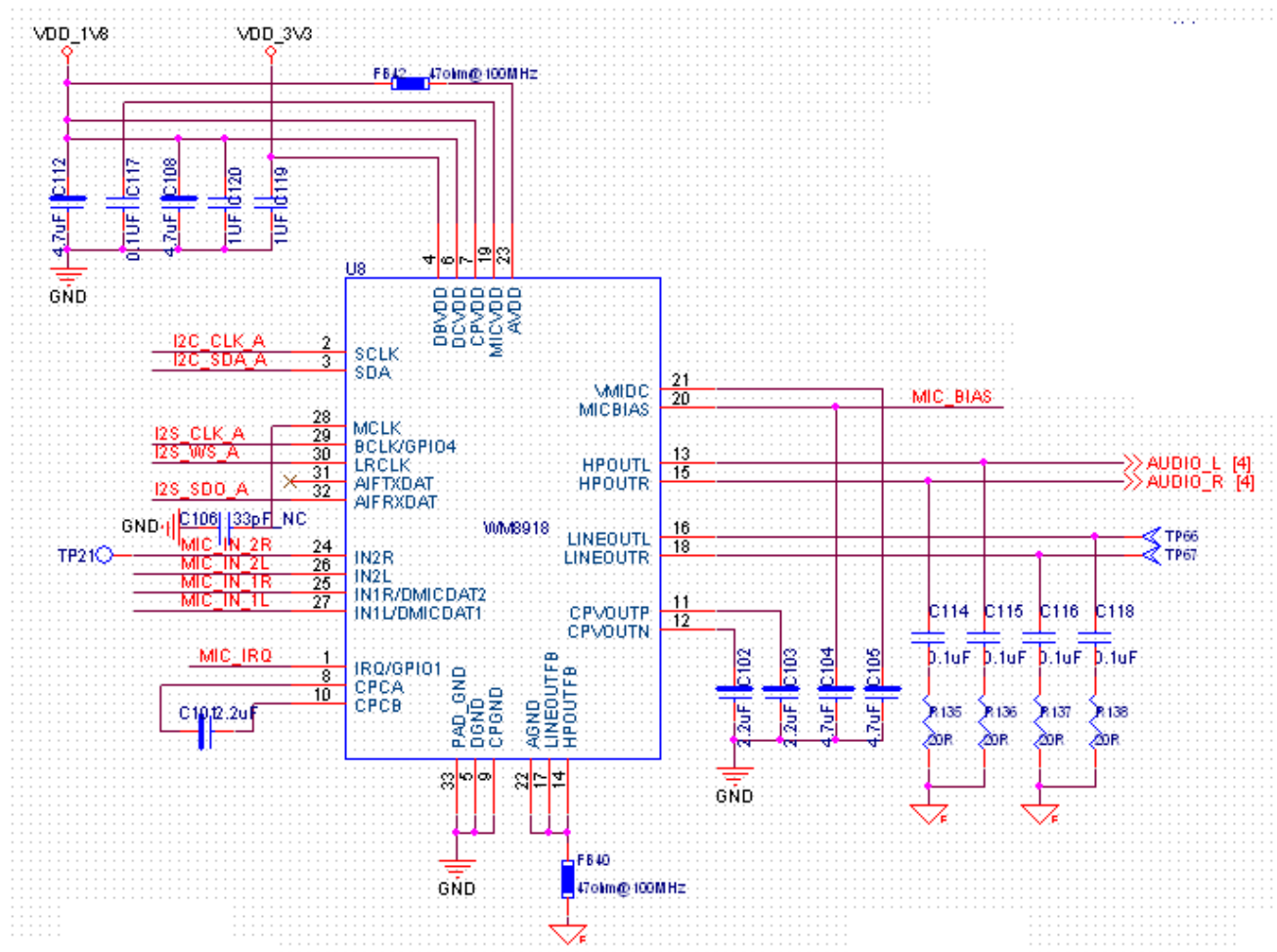

Table 2-3 Connect with external audio IC with A31-2 module

Notes:

Please see the following documents for details:
 WIFIAudio_Module_Design_Note_V03.pdf
 WIFIAudio A31-2 Reference Design_4.pdf

- Slave mode:

When A31-2 module is working as I2S slave mode, it needs the external input for both I2S_WS and I2S_CLK. Here we use the MVSilicon’s MCU/Codec chip AP8048/AP8064 as an example to explain how to connect the module as the I2S slave. The connection method and function description are as follows:

- 1) **Case 1:** Wi-Fi, BT or AUX IN can be connected to AP8048/8064 directly. The AP8048 etc. will decide which source (Wi-Fi/BT/AUX IN) is output to connected digital amplifier.

How to connect I2S pin of A31-2: I2S DATA OUT of A31-2 is connected to I2S DATA IN of AP8048/8064. The I2S DATA OUT of AP8048 is connected to the amplifier. The advantage of doing this is: power saving, i.e., Wi-Fi or BT could be switched off independently.

Doc Title	Wireless smart audio module	Number	WMB20150921
		Version	1.0

2) **Case 2:** AUX IN and BT could be converted to digital I2S input for A31-2 by AP8048. It is possible to re-transmit these inputs through Wi-Fi to other speakers and output it to digital amplifier simultaneously. Therefore, we could achieve the multi-room audio for Aux-in and BT sources with this configuration.

To connect with amplifier with digital input, the I2S DATA OUT of AP8048 is connected with DATA IN of A31-2, DATA OUT of A31-2 is connected with amplifier. A31-2 will be responsible for receiving data then re-transmit to other slave speakers during multi-room playback

To connect with amplifier with analog input, the I2S DATA OUT of AP8048 needs to be connected with the I2S DATA IN of A31-2, and I2S DATA OUT of A31-2 needs to be connected with the DATA IN of AP8048. AP8048 will be responsible for output analog audio data to amplifier.

Notes: There is an advantage to use amplifier with analog input. The EQ module in AP8048 could be used to improve the sound quality.

Notes:

- Please see the following documents for details:
- WIFIAudio_Module_Design_Note_V03.pdf
- WIFIAudio A31-2 Reference Design_1/2/3.pdf

2.4. External antenna

A31-2 uses the external antenna for best Wi-Fi performance. To use external antenna, please choose the antenna type that meets the requirement of IEEE 802 b/g/n WiFi standard running at 2.4GHz frequency. The detailed parameters are shown in the table below.

Items	Parameters
Frequency range	2.4~2.5GHz
Impedance	50 Ohm
VSWR	2 (Max)
Reflection loss	-10dB (Max)
Connector	I-PEX or populate directly

Table 2-5 A31-2 external antenna parameters

2.5. 10/100M Ethernet Port

A31-2 module provides 10/100Mbps Ethernet interface pins that could be used to connect with Ethernet RJ45 socket. It has built-in transformer.

Doc Title	Wireless smart audio module	Number	WMB20150921
		Version	1.0

2.5.1. Connect the module with RJ45

To provide 10/100Mbps Ethernet functionality, you could connect the module with the RJ45 socket via a Ethernet transformer. The detailed diagram is as follows:

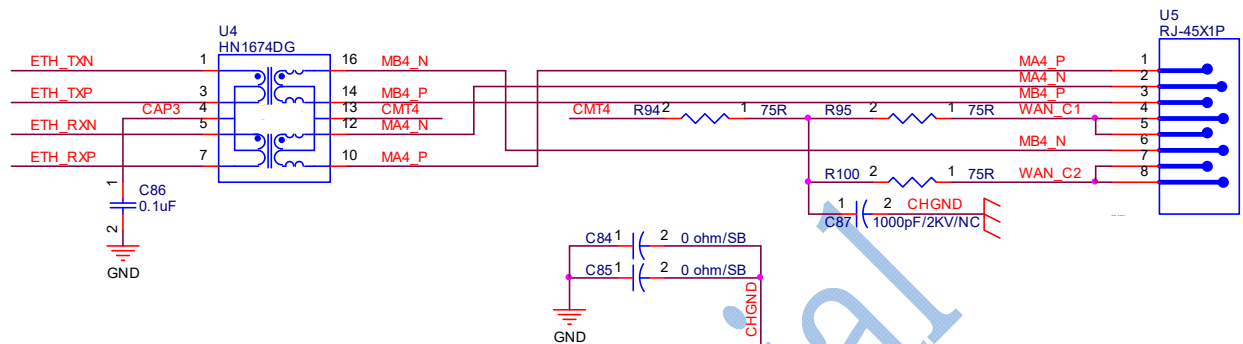

Figure 2-4 The reference design of Ethernet

2.6. USB host port

A31-2 module provides high speed USB2.0 host interface. To connect with USB port, the reference design is shown below.

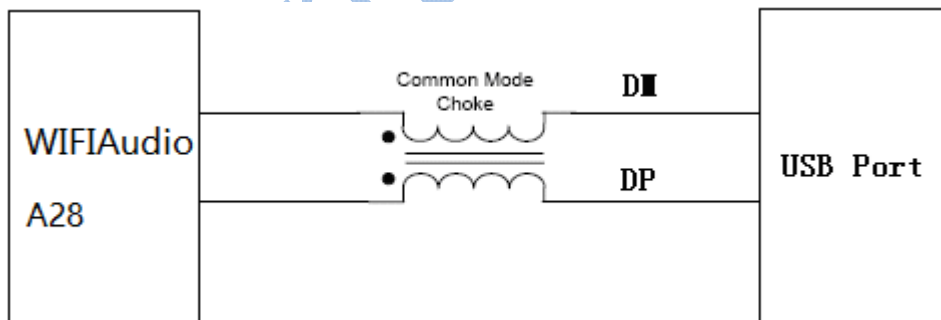

Figure 2-5 USB host interface

Please follows the following design rule to populate the USB host interface:

Item	Parameter
Signal Group	USB

Doc Title	Wireless smart audio module	Number	WMB20150921
		Version	1.0

Topology	Differential Pair Point-to-Point
Reference Plane	Ground Referenced
Characteristic Trace Impedance (Zo)	90 Ω \pm 10%
Trace Width	4 mils
Serpentine Spacing(center to center)	8.5 mils
Minimum Isolation Spacing to Clock Signals	50 mils
Minimum Isolation Spacing to Low-Speed Signals	20 mils
Minimum Isolation Spacing to other USB Pair	20 mils
Total Length (with package length)	Max = 8000 mils
Maximum Recommended Via Count	2 (per side)
DM to DP Length Matching(with package length)	Match total length to within \pm 10 mils

Table 2-6 WiFiAudio-A31-2 USB design rule

2.7. Power supply

A31-2 module can be powered with single power supply with voltage between 3.5V and 5.5V. The peak current is around 300mA, the normal working current is 170mA. In sleep mode (when Wi-Fi is off), the current is 20mA.

The power supply is important for system stability and Wi-Fi performance. It is recommended to use 100uF and 10uF decoupling capacitor in parallel to reduce the ripple of power supply.

2.8. Silkscreen and Package

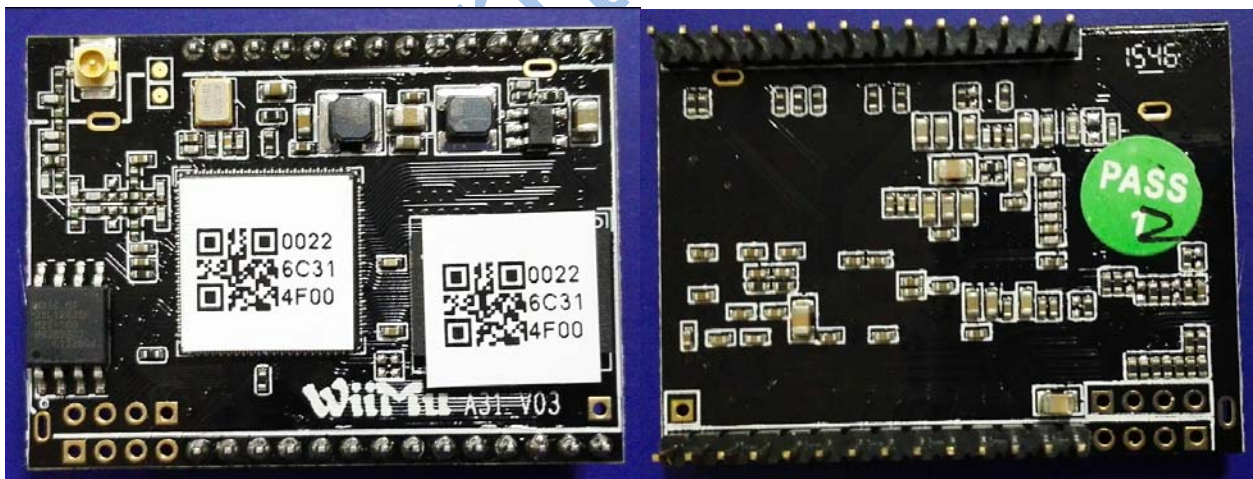

Remark:

Wiimu: English logo

A31: Internal product code

V03: A31 revision code

Doc Title	Wireless smart audio module	Number	WMB20150921
		Version	1.0



Remark:

1 tray: 30 pcs

1 carton: 15 trays

Total of 1 carton: 15*30 pcs=450 pcs

3. Software

WiFiAudio-A31-2 supports Airplay and DLNA functionality:

Items	Description
iOS version	<ul style="list-style-type: none"> ● iOS 4.2 and above ● iPhone, iPad, iPod Touch, iPad Mini
iTune version	<ul style="list-style-type: none"> ● iTunes 10.2 and above ● PC, iMac
Network setup	<ul style="list-style-type: none"> ● A31-2 works in AP Client mode ● Support WPS and proprietary Wi-Fi setup
Support Airplay mode	<ul style="list-style-type: none"> ● Play, Pause, Seek, Volume, Prev, Next
Airplay applications	<ul style="list-style-type: none"> ● Apple Music App. ● QQ Music ● iTunes ● Many third party music applications ...
DLNA operations	<ul style="list-style-type: none"> ● Play, Pause, Seek, Volume, Prev, Next
DLNA applications	<ul style="list-style-type: none"> ● Compatible with DLNA certified player, i.e., <ul style="list-style-type: none"> ■ Skifta ■ BubbleUPnP

Doc Title	Wireless smart audio module	Number	WMB20150921
		Version	1.0

Audio format support	<ul style="list-style-type: none"> ● MP3, WMA, WAV, Apple Lossless (ALAC), AAC, AAC+, FLAC, APE, OGG
Browser support	<ul style="list-style-type: none"> ● PC: IE9/10, Chrome, Firefox ● iOS/MAC OS: Safari
Language support of Web server	<ul style="list-style-type: none"> ● Chinese ● English
Setup with web server	<ul style="list-style-type: none"> ● Setup A31-2 network ● Setup A31-2 device name, add password protection ● Update A31-2 firmware and restore factory setting ● Online update firmware ● Connect device to Internet

Table 3-1 A31-2 software description

3.1. Airplay introduction

AirPlay is the streaming standard developed by Apple Inc. It lets you wirelessly stream what's on your iOS device to your HDTV or speaker. It is supported starting from iOS4.2 and OS X Mountain Lion. It can also stream the music in PC or Mac via iTunes 10.1 or above.

When the user devices (including iMac, PC, iPod touch, iPhone, iPad) are in the same WiFi LAN with the speaker that supports Airplay, when the user device launches the applications such as iTunes or iOS music applications, the

Airplay button  appears. When click the Airplay button, please choose the speaker that you want to stream to.

3.2. DLNA introduction

Digital Living Network Alliance (DLNA) is an organization formed by companies in consumer electronics, cellphone and PC fields. The device with DLNA certification could seamlessly works with other DLNA devices

without compatibility issue. The device has  dlna logo.

3.3. WiFi mode

WiFiAudio-A31-2 module is working at WiFi AP Client mode. To setup AP client mode, please setup with web browser when you connect with the device via WiFi or Ethernet.

Doc Title	Wireless smart audio module	Number	WMB20150921
		Version	1.0

3.3.1. AP Client mode

Device working under AP Client could serve as AP and client simultaneously. When it is used as AP, other wireless device could connect with it directly. Meanwhile, it could connect to other wireless AP as a wireless station. In this mode, device could connect with WiFiAudio-A31-2 and playback music to this device with airplay or DLNA. Meanwhile, if WiFiAudio-A31-2 is connected with main wireless AP that is connected to Internet, the device that is connected with WiFiAudio-A31-2 has access to Internet too.

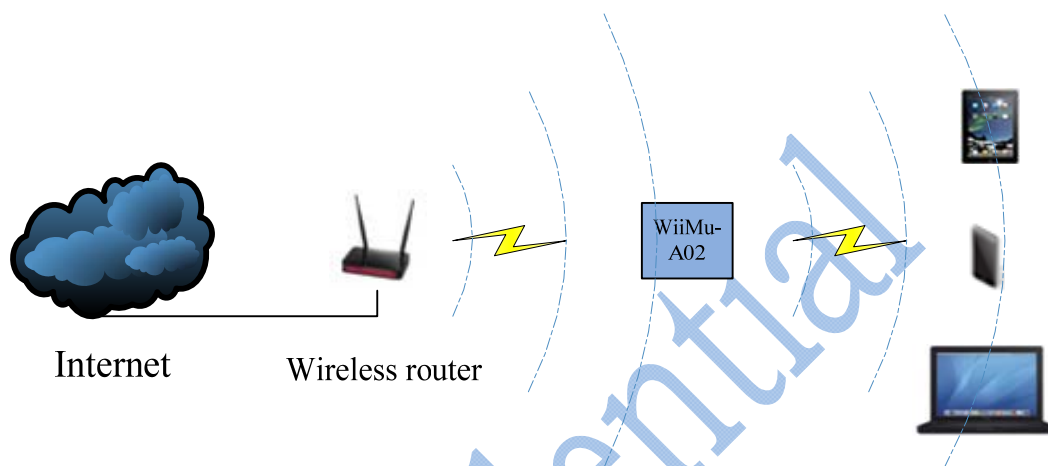

Figure 3-1 WiFiAudio-A31-2 AP Client mode

3.4. Web Server setup

WiFiAudio-A31-2 module provides built-in web server to let user configure the module via the Internet browser. In the factory mode, the SSID of WiFiAudio-A31-2's AP port is in the form of WiFiAudio_XXXX. The XXXX represent four digital numbers. The IP address, user name and password are shown below:

Parameters	Default setting
SSID	WiFiAudio_XXXX
IP address	10.10.10.254
Mask	255.255.255.0
DNS	WiiMu.com
User name	admin
Password	admin

Table 3-2 WiFiAudio-A31-2 AP default parameters

You could use PC, iOS or Android device connect the WiFiAudio-A31-2 first as wireless AP, then launch the browser and login to web server and configure the module. It supports IE8.0 or up, Chrome and Safari Internet browser.

Doc Title	Wireless smart audio module	Number	WMB20150921
		Version	1.0

3.4.1. Web server login

When the user devices are in the same network as WIFIAudio-A31-2 the user could login to the built-in web server by entering “http://10.10.10.254” or “http://wiimu.com” in the Internet browser. Currently, both English and Chinese language are supported in the web server and could be configured in the setup page. However, it is also possible to add other language support. The following example is shown in English as it is selected as the default language in the web server.

If the WIFIAudio-A31-2 device is not connected to another AP to get Internet access, the web server will be directed to the WIFI setup page. In this page, the user could choose the AP to connect. Otherwise, if it is already connected with another AP, it will be redirected to the setting page for other settings.

3.4.2. Connecting the module to another AP

In this page, the network information such as the connected AP and list of available AP are displayed. Please see the details in Figure 3-2. The user could select the AP to connect to provide the module with Internet access. Meanwhile, the module could serve as the AP for other devices that could directly connect with the module. In the case, the module worked as “AP client” or so called bridge mode.

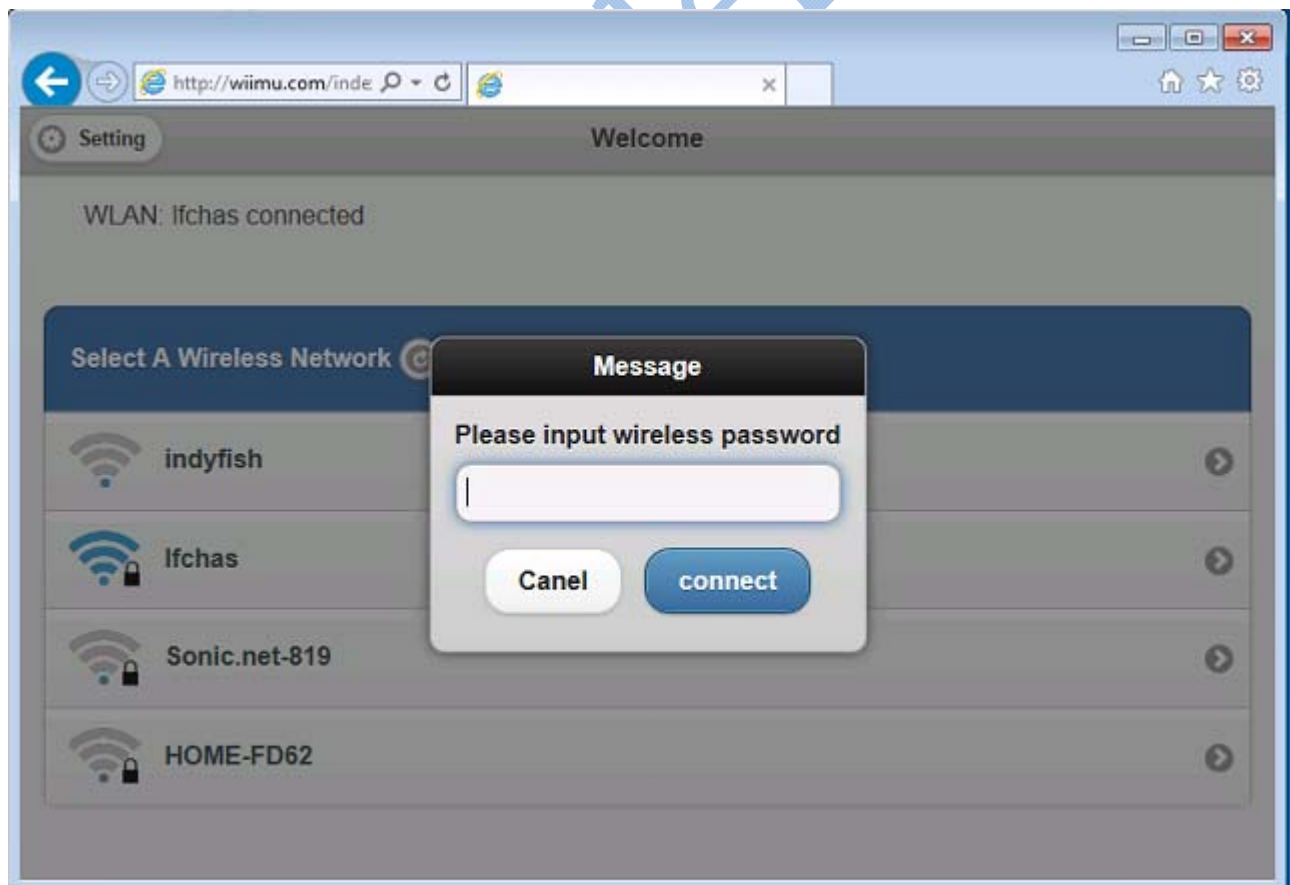

Doc Title	Wireless smart audio module	Number	WMB20150921
		Version	1.0

Figure 3-2 Connect WiFiAudio-A31-2 with another AP

After entering the password for the connected AP, there is pop up message window to remind you that the user device should be in the same network as WiFiAudio-A31-2 in order to use it , i.e., the user device is connected to the module directly or the AP that the module is connected to.

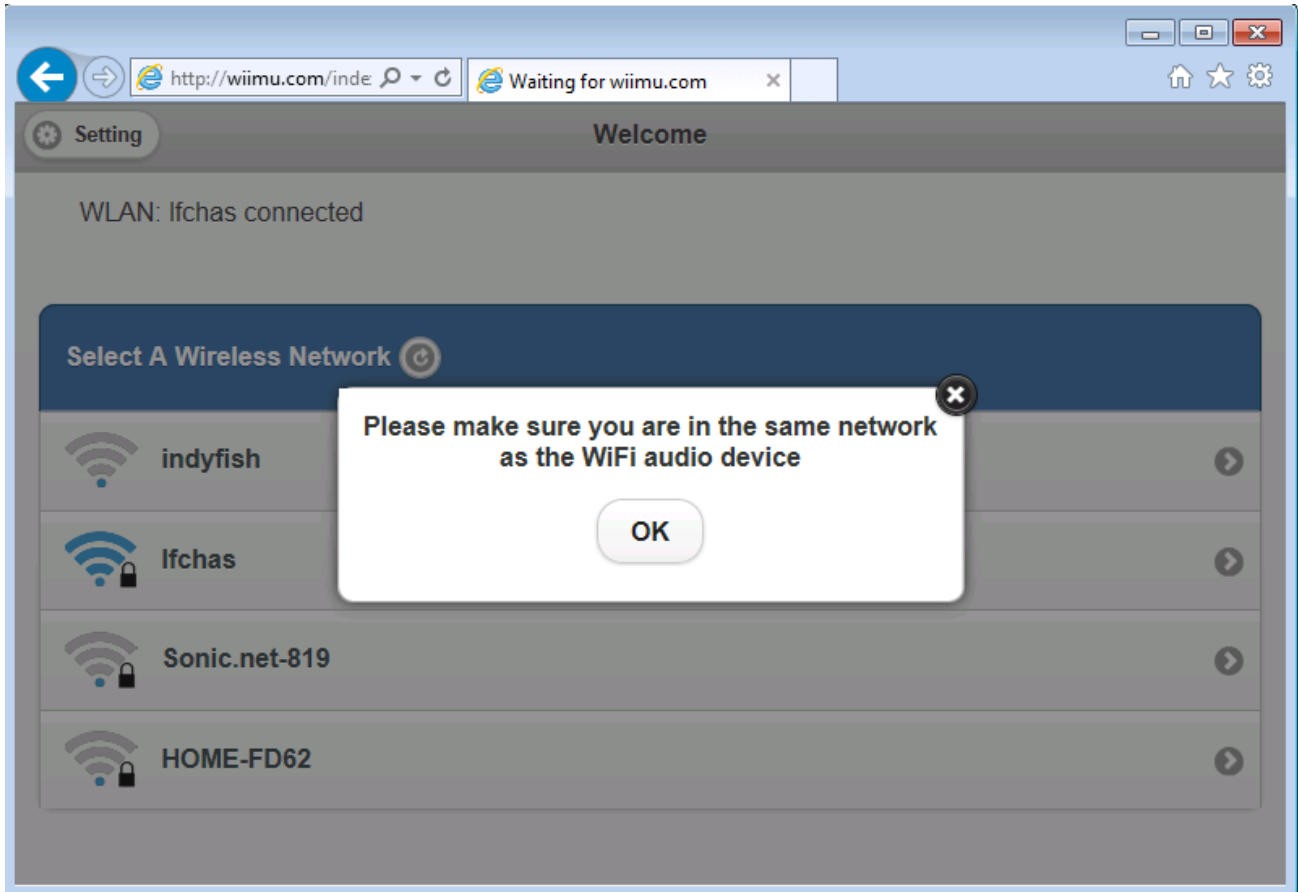

Figure 3-3 Keep the device and WiFiAudio-A31-2 in the same network

3.4.3. Advanced setting for the module

Press the setting button in top left corner of the WiFi setup page to enter the page for advanced settings. There are three setting fields such as device information, module and wireless LAN setting.

3.4.3.1. Module setting page

It is used to perform manual software upgrade, restore factory settings and setup the default language.

3.4.3.1.1. Software upgrade

Important: software upgrade is the critical operation so please be cautious of doing this. In the process of

Doc Title	Wireless smart audio module	Number	WMB20150921
		Version	1.0

software upgrade, please don't playback any music or any other operation except the software upgrade. Please don't disconnect the power for the module during the process.

It is also possible to use the online update if the device is connected with the Internet by press the "Check Online update" button in the software upgrade page. The module will then check if there is updated version in the remote maintenance server.

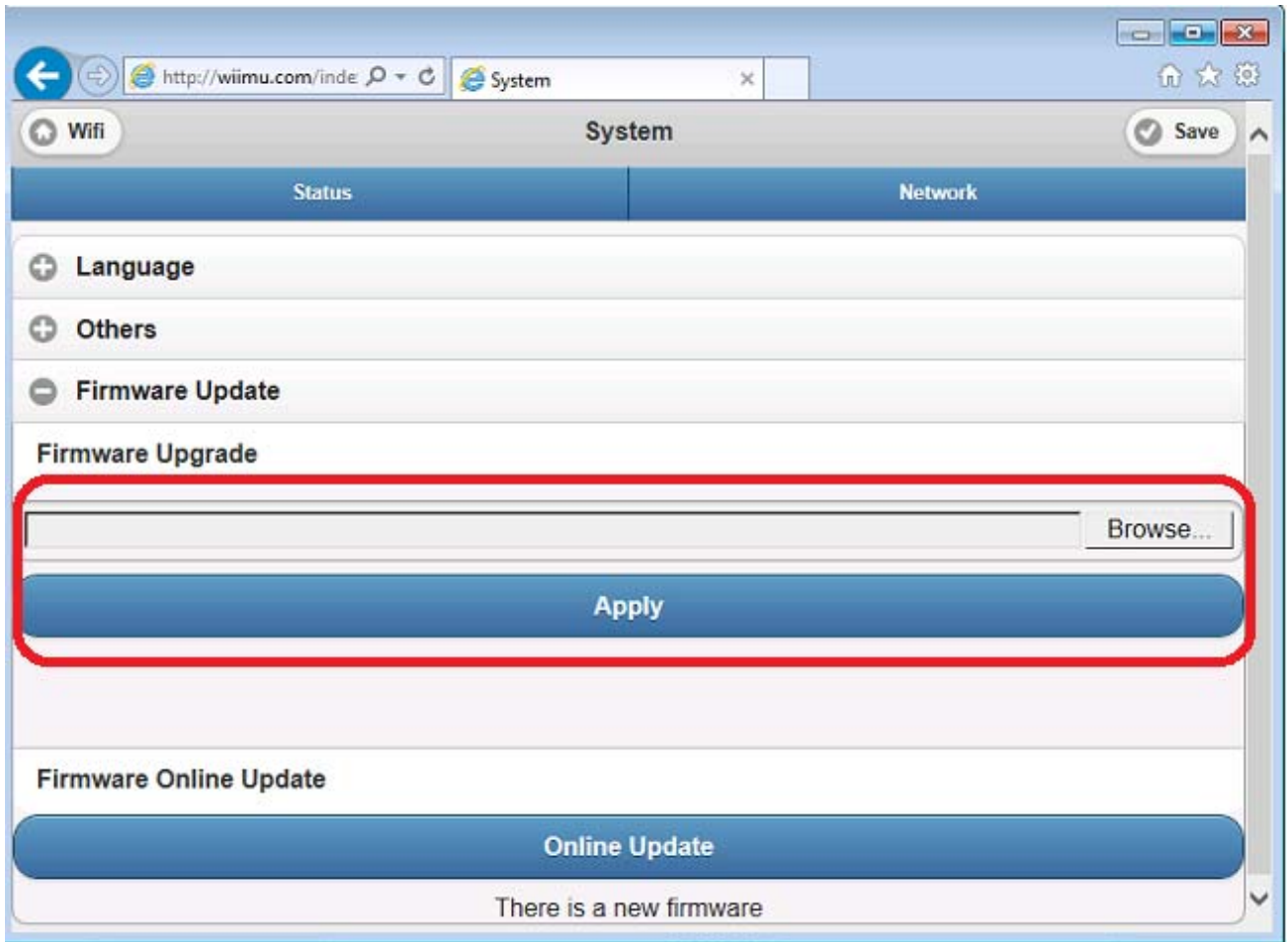

Figure 3-4 Upgrade the module firmware manually

3.5. Use UART to debug

The UART needs setup as follows:

Baud rate	57600
Data bit	8
Parity bit	None
Stop bit	1

Doc Title	Wireless smart audio module	Number	WMB20150921
		Version	1.0

Flow control

DTR/DSR None

RTS/CTS None

XON/XOFF None

3.6. WPS Setting

WPS (Wi-Fi Protected Setup) is used to simplify the Wi-Fi setup. Working with WPS enabled router, user doesn't need choose the Wi-Fi SSID and enter password. Instead, user just needs press the button (PBC mode) and it will join the network safely.

To enter the WPS mode, keep low pulse (300ms < t <5s) for “nReload” pin in A31-2 module.

3.7. Restore to factory setting

To restore the factory setting for the module, keep low pulse for t >5s for “nReload” pin in the A31-2 module. When the factory setting is restored, the system will reboot automatically.

Confidential

FCC Warning

This device complies with Part 15 of the FCC Rules. Operation is subject to the following two conditions:

- (1) this device may not cause harmful interference, and
- (2) this device must accept any interference received, including interference that may cause undesired operation.

NOTE: Any changes or modifications to this unit not expressly approved by the party responsible for compliance could void the user's authority to operate the equipment.

FCC Radiation Exposure Statement:

This equipment complies with FCC radiation exposure limits set forth for an uncontrolled environment. End users must follow the specific operating instructions for satisfying RF exposure compliance.

Note 1: This module certified that complies with RF exposure requirement under portable or mobile or fixed condition, this module is to be installed only in portable or mobile or fixed applications.

A portable device is defined as a transmitting device designed to be used so that the radiating structure(s) of the device is/are within 20 centimeters of the body of the user

A mobile device is defined as a transmitting device designed to be used in other than fixed locations and to generally be used in such a way that a separation distance of at least 20 centimeters is normally maintained between the transmitter's radiating structure(s) and the body of the user or nearby persons. Transmitting devices designed to be used by consumers or workers that can be easily re-located, such as wireless devices associated with a personal computer, are considered to be mobile devices if they meet the 20 centimeter separation requirement.

A fixed device is defined as a device is physically secured at one location and is not able to be easily moved to another location.

Note 2: Any modifications made to the module will void the Grant of Certification, this module is limited to OEM installation only and must not be sold to end-users, end-user has no manual instructions to remove or install the device, only software or operating procedure shall be placed in the end-user operating manual of final products.

Note 3: The device must not transmit simultaneously with any other antenna or transmitter.

Note 4: To ensure compliance with all non-transmitter functions the host manufacturer is responsible for ensuring compliance with the module(s) installed and fully operational. For example, if a host was previously authorized as an unintentional radiator under the Declaration of Conformity procedure without a transmitter certified module and a module is added, the host manufacturer is responsible for ensuring that the after the module is installed and operational the host continues to be compliant with the Part 15B unintentional radiator requirements. Since this may depend on the details of how the module is integrated with the host, LM Technologies Ltd. shall provide guidance to the host manufacturer for compliance with the Part 15B requirements.

Note 5: FCC ID label on the final system must be labeled with “Contains FCC ID: 2AAPP-A31 or “Contains transmitter module FCC ID: 2AAPP-A31”.

The transmitter module must be installed and used in strict accordance with the manufacturer's instructions as described in the user documentation that comes with the host product. Wiimu Information Technology Inc. is responsible for the compliance of the module in all final hosts.