



SX-SDWAG 802.11a/b/g SDIO Module User Manual

© 2008 Silex Technology America, Inc. All rights reserved.
September, 2008

Silex Technology America SPECIFICALLY DISCLAIMS THE IMPLIED WARRANTIES OF MERCHANTABILITY AND FITNESS OF THIS PRODUCT FOR A PARTICULAR PURPOSE. Silex shall not be liable for any errors contained in this manual or for any damages resulting from loss of use, data, profits, or any incidental or consequential damages arising from the use of SILEX products or services. The information contained in this documentation is subject to change without notice.

Information and descriptions contained herein are the property of Silex. Such information and descriptions may not be copied, disseminated, or distributed without the express written consent of Silex. This publication is subject to change without notice.

Trademarks

ExtendView is a trademark of Silex Technology America, Inc. All other company or product names referenced in this document may be trademarks or registered trademarks of their respective owners.

Silex Technology America, Inc.

www.silexamerica.com

Contents

About This User Manual	1
Safety Precautions	1
Emissions Disclaimer	1
Chapter 1: Introduction	2
Chapter 2 Hardware Specifications/Compliance	3
FCC Information	3
Information for Canadian Users (IC Notice)	4
Specifications	5
Chapter 3 Installation	6
Installation Requirements	6
Installation Procedure	6
Appendix A Antenna Information	8
Antenna Cable Drawings and Specifications	8
Antenna Drawings and Specifications	9
Appendix B Silex Contact Information	11

About This User Manual

This user manual provides detailed specifications, diagrams and additional information required to install the SX-SDWAG 802.11a/b/g SDIO module into a product. The intended audiences are the developers and engineers responsible for the integration of the module in another product.

Safety Precautions

- To prevent damage to the SX-SDWAG module's electronic circuit components, follow established ESD practices and procedures for handling static-sensitive devices. All ESD-sensitive components must be stored and shipped in ESD-conductive bags or bubble-wrap and labeled as such using the standardized ESD adhesive warning label.
- Ethernet electrical wiring must be at least 6 feet from bare power wiring or lightning rods and associated wires, and at least 6 inches from other types of wire (antenna wires, doorbell wires, wires from transformers to neon signs), steam or hot water pipes, and heating devices.
- Protectors and grounding wire placed by the service provider must not be connected to, removed, or modified by the customer.

Emissions Disclaimer

Final emission certification per FCC, CE and other agency requirements are the responsibility of the OEM (refer to chapter 2 for additional information).

Chapter 1: Introduction

The SX-SDWAG is an 802.11a/b/g radio/baseband module in a standard SDIO form factor. 1a/b/g capabilities in an SDIO card form factor. Designed for wireless local area network (WLAN) applications that require low power consumption, the SX-SDWAG is ideal for battery-operated portable devices in the medical, weights and measures, transportation and other industries.

SX-SDWAG features include:

- Highly Integrated System for 802.11a/b/g WLAN
- U.FL antenna connectors with diversity support
- Wide operating temperature range
- Integrated Atheros AR6001XL Single Chip
- Integrated high performance Dual-Band Front End Module (FEM), Band Pass Filter, 40MHz Crystal
- 4Kbit EEPROM
- Advanced power management to minimize standby and active power
- WEP 64/128, WPA (TKIP), WPA2 (802.11i) security
- Linux, Windows CE, and Windows Mobile drivers available from Silex (porting will be required in most cases)
- Compatible with Sourceforge (Linux) and Codeplex (WinCE 6.0) Open Source Drivers (firmware downgrade may be required; contact Silex for details)

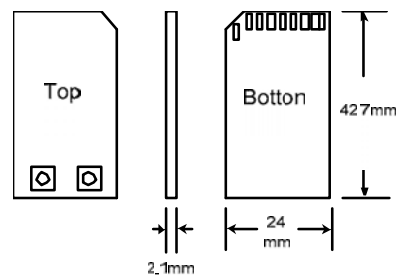

Figure 1 SX-SDWAG Dimensions

Chapter 2 Hardware Specifications/Compliance

FCC Information

FCC ID: N6C-SXDWAG

NOTICE

In accordance with FCC Part 15, the SX-SDWAG is listed as a Modular Transmitter device. End products that include the SX-SDWAG shall have the words “Contains Transmitter module FCC ID: N6C-SXSDWAG” on an exterior label.

This equipment complies with Part 15 of the FCC Rules. Operation is subject to the following two conditions: (1) this device may not cause harmful interference, and (2) this device must accept any interference received, including interference that may cause undesired operation.

This equipment has been tested and found to comply within the limits for a Class B digital device, pursuant to part 15 of the FCC Rules. These limits are designed to provide reasonable protection against harmful interference in a residential installation.

This equipment generates, uses, and can radiate radio frequency energy and, if not installed and used in accordance with the instructions, may cause harmful interference to radio communications. However, there is no guarantee that interference will not occur in a particular installation. If this equipment does cause harmful interference to radio or television reception, which can be determined by turning the equipment off and on, the user is encouraged to try to correct the interference by one or more of the following measures:

- Reorient or relocate the receiving antenna
- Increase the separation between the equipment and receiver
- Connect the equipment into an outlet on a different circuit from that to which the receiver is connected
- Consult the dealer or an experienced radio/TV technician for help.

The transmitter must not be co-located or operated in conjunction with any other antenna or transmitter.

The available scientific evidence does not show that any health problems are associated with using low power wireless devices. There is no proof, however, that these low power wireless devices are absolutely safe. Low power wireless devices emit low levels of radio frequency energy (RF) in the microwave range

while being used. Whereas high levels of RF can produce health effects (by heating tissue), exposure to low-level RF that does not produce heating effects causes no known adverse health effects. Many studies of low-level RF exposures have not found any biological effects. Some studies have suggested that some biological effects might occur, but such findings have not been confirmed by additional research.

To satisfy RF exposure requirements, this device and its antenna(s) must operate with a separation distance of at least 20 centimeters from all persons and must not be co-located or operated in conjunction with any other antenna or transmitter. End-users must be provided with specific operating instructions for satisfying RF exposure.

FCC WARNING:

Changes or modifications not expressly approved by the party responsible for compliance could void the user's authority to operate the equipment.

Information for Canadian Users (IC Notice)

The term "IC" before the radio certification number only signifies that Industry Canada technical specifications were met. Operation is subject to the following two conditions: (1) this device may not cause interference, and (2) this device must accept any interference, including interference that may cause undesired operation of the device.

This Class B digital apparatus meets all requirements of the Canadian Interference-Causing Regulations.

To prevent radio interference to the licensed service, this device is intended to be operated indoors and away from windows to provide maximum shielding. Equipment that is installed outdoors is subject to licensing.

This device has been designed to operate with an antenna having a maximum gain of 2dB. Antennas having a higher gain are strictly prohibited per regulations of Industry Canada. The required antenna impedance is 50 ohms.

To reduce potential radio interference to others, the antenna type and its gain should be so chosen that the equivalent isotropically radiated power (EIRP) is not more than required for successful communication.

The device for the band 5150-5250MHz is for indoor usage to reduce potential for harmful interference to co-channel Mobile Satellite systems.

The available scientific evidence does not show that any health problems are associated with using low power wireless devices. There is no proof, however, that these low power wireless devices are absolutely safe. Low power wireless devices emit low levels of radio frequency energy (RF) in the microwave range while being used. Whereas high levels of RF can produce health effects (by heating tissue), exposure to low-level RF that does not produce heating effects causes no known adverse health effects. Many studies of low-level RF exposures have not found any biological effects. Some studies have suggested that some biological effects might occur, but such findings have not been confirmed by additional research.

Specifications

Operating environment:	Temperature: -40° to +70°C (-40° to +158°F) Humidity: 10% to 90%
Storage environment:	Temperature: -40° to +85°C (-40° to +185°F) Humidity: 10% to 90%
Supply voltage:	3.3V ± 5%
Host interface:	SDIO
Frequency bands and modulations:	
IEEE 802.11b	Frequency: 2412MHz-2462MHz Transmission system: DSSS Transmission speed: 1/2/5/11Mbps Automatic detection Channel: 1-11
IEEE 802.11g	Frequency: 2412MHz-2462MHz Transmission system: OFDM Transmission speed: 6/9/12/18/24/36/48/54Mbps Automatic detection Channel: 1-11
IEEE 802.11a	Frequency: 5180MHz-5240MHz, 5745-5825MHz Transmission system: OFDM Transmission speed: 6/9/12/18/24/36/48/54Mbps Automatic detection Channel: 36-48, 149-165
Frequency stability	
2.4GHz operation	±20ppm (40MHz)
5GHz operation	±20ppm (40MHz)

Chapter 3 Installation

Installation Requirements

The SX-SDWAG must be installed in a device that contains a 9-pin SDIO slot.

The SX-SDWAG has FCC modular approval, which can eliminate the need for you obtain FCC Part 15 Subpart C and E (intentional radiation) approvals for your device. In order to use this FCC modular approval for the SX-SDWAG, you must:

1. Include “Contains FCC ID: N6C-SXSDWAG” on the label of your device.
2. Use the Silex dipole antenna (refer to appendix A) or an equivalent dipole antenna with equal or lower gain.
3. Use the special Silex antenna cable (includes ferrites for additional EMI suppression; refer to Appendix A)

If you do not follow the above instructions, then it is your responsibility to obtain the necessary FCC approvals.

Installation Procedure

To install the SX-SDWAG:

1. Be sure to use the proper antistatic handling techniques.
2. Insert the SX-SDWAG into an available SDIO slot in your device. Make sure that it is securely seated.
3. Connect one end of the antenna cable to the main antenna connector on the SX-SDWAG (see figure 2). If you are using a diversity antenna configuration, connect one end of the second antenna cable to the secondary antenna on the SX-SDWAG.

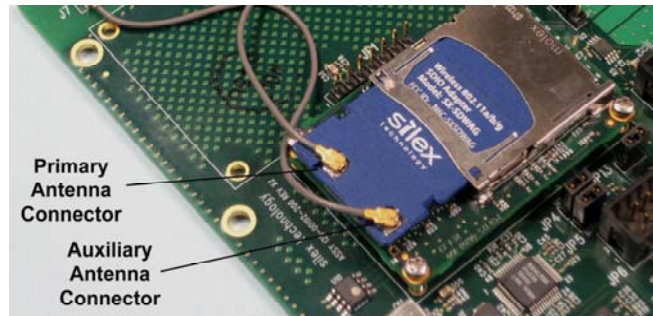

Figure 2 Connecting the Antenna Cable(s) to the SX-SDWAG

4. If your device is subject to significant vibration or other forces, Sillex recommends the use of a retaining bracket to prevent the accidental ejection of the card. This bracket can be the Sillex 150-00192-100 retaining bracket (see figure 3) or an equivalent custom-made bracket.

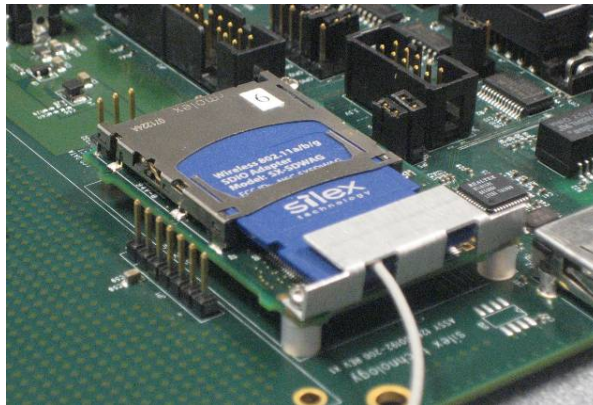
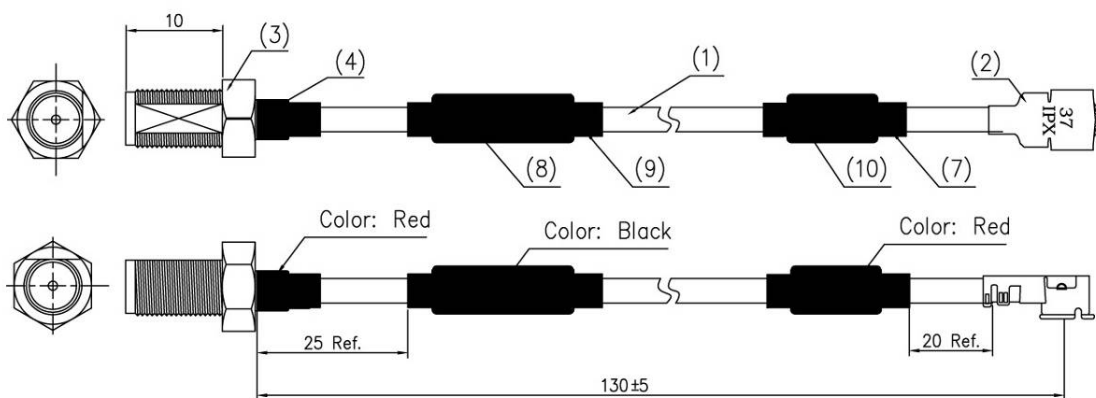

Figure 3 Securing the SX-SDWAG with Optional Bracket

5. Connect the other end of the cable(s) to the antenna(s).

Appendix A Antenna Information

Antenna Cable Drawings and Specifications



10	SHRINK TUBE (ø4) Red	1
9	SHRINK TUBE (ø6~7) BLACK	1
8	CORE OD ø6*ID ø2*L 25	1
7	CORE ø4*10*2	1
6	NUT	1
5	TOOTH WASHER	1
4	SHRINK TUBE (ø3.0~3.5) Red	1
3	RP-SMA-JACK (10mm) Blk Special	1
2	I-PEX PLUG (20351-111R-37)	1
1	COAXIAL CABLE ø1.37 White	1

Figure 2 Antenna Cable Assembly

Table 1 Electrical Performance

Parameter	Value
Impedance	50 ohms
Frequency Range	1 to 6 GHz
Working Voltage	500 VAC (rms) maximum
Dielectric Withstanding Voltage	1000 VAC (rms) maximum
Insulator Resistance	1000 megohms minimum

Antenna Drawings and Specifications

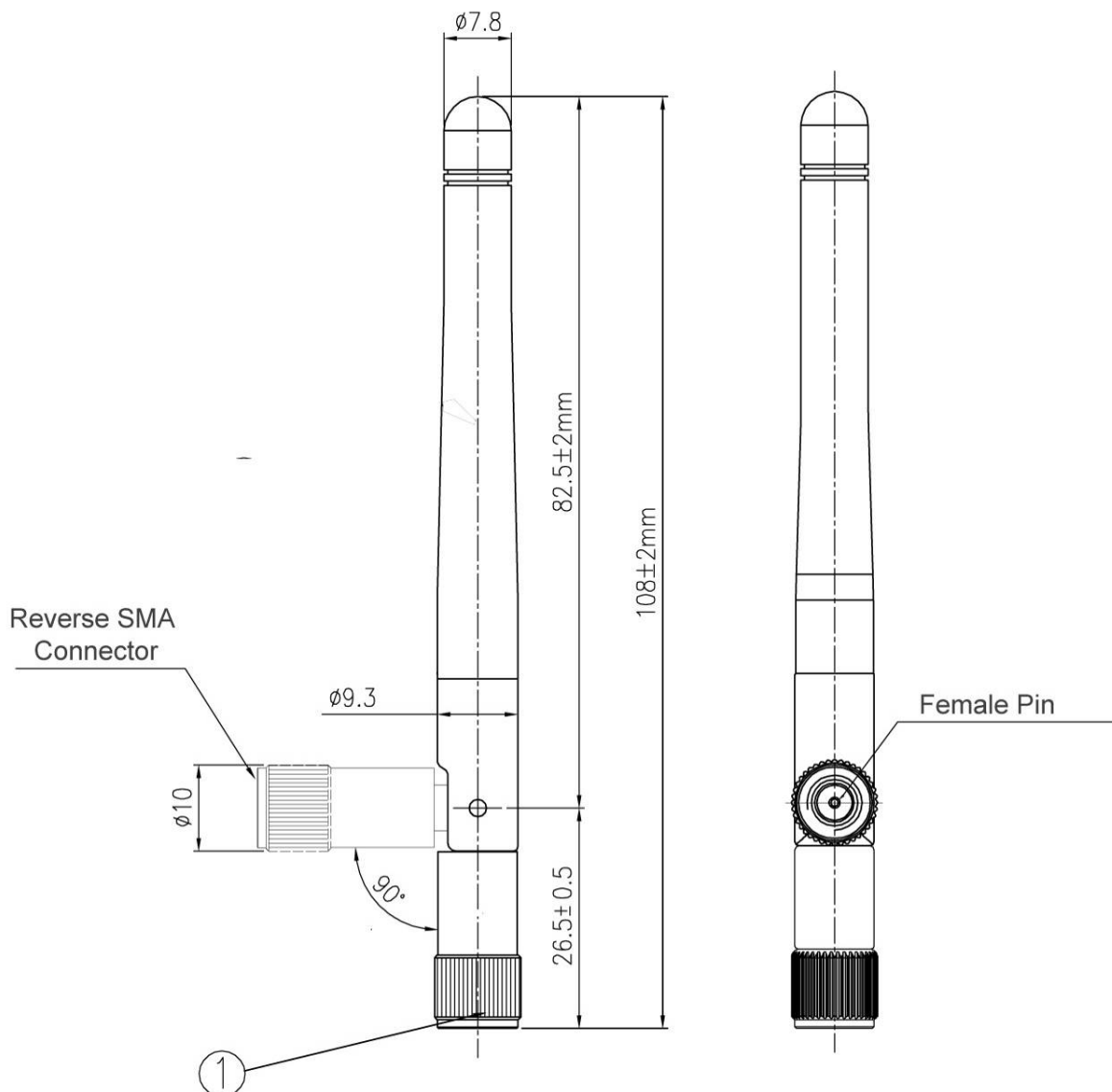

Figure 28 Antenna Mechanical Drawing

Table 2 Electrical Specifications

Parameter	Value
Antenna Type	Dipole Swivel Antenna
Frequency Range	2.4 to 5.8 GHz
Impedance	50 Ohms
Gain	2.4 GHz < 1.5 dBi 5.825 GHz < 2.1 dBi
VSWR	≤ 2.0
Admitted Power Radiation	Omni
Polarization	Vertical
Electrical Length	¼ n Dipole
Standard Connector	SMA — male reverse

Appendix B Silex Contact Information

Silex Technology America, Inc.

www.silexamerica.com

Technical Support: support@silexamerica.com

Sales: sales@silexamerica.com

Tel: (801) 748-1199 8:00 to 5:00 Mountain Time

Tel: (866) 765-8761 toll-free

Fax: (801) 748-0730

Silex Technology Europe GmbH

www.silexeurope.com

Tel: +49-2159-67500

Tel: 0800-7453938 German toll free

Email: contact@silexeurope.com

Silex Technology Beijing, Inc.

www.silex.com.cn

Tel: +86-10-8497-1430

Email: contact@silex.com.cn

Corporate Headquarters

Silex Technology, Inc.

www.silex.jp

Tel: +81-6-6730-3751

Email: support@silex.jp



[Silex](http://www.silexamerica.com) Technology America, Inc.
www.silexamerica.com

Revision A-1