



OZMO2000WM014A Wireless Module

User guide

APP-0133-AN-V1.2 – July 2012

1 General Description

The OZMO2000WM014 Wireless Module is a fully assembled and tested general-purpose module using the OZMO2000 wireless System-on-Chip (SoC). The module contains the OZMO2000 chip, memory, antenna, and all other necessary components to operate the OZMO2000.

The memory is preloaded with firmware that is compatible with Windows 7 SoftAP or Wi-Fi CERTIFIED™ Wi-Fi Direct host systems.

With modified firmware, the OZMO2000 can support other interfaces, such as I²C and GPIO. Contact your Ozmo FAE for assistance with these interfaces.

For detailed information on the OZMO2000 component itself, refer to the OZMO2000 datasheet.

2 Features

Small, self-contained SMT module

On-board memory stores OZMO2000 program image, MAC address and security credentials

On-chip regulators allow direct connection to battery or unregulated supply between 1.8V and 3.6V. (certain limitations may apply depending on module version)

Total module height is 4mm

3 Benefits

On-board 8051 processor eliminates need for external micro-controller.

Flexible application interfaces included: I2C, PCM/I2S, GPIOs, LED drivers with PWM.

Great battery life thanks to low power radio and systems design.

Low latency thanks to agile systems architecture and fast wake up algorithms.

4 Table of Contents

OZMO2000WM014 Wireless Module	1
User guide	1
1 General Description	1
2 Features	1
3 Benefits	1
4 Table of Contents.....	2
5 Applications information.....	3
5.1 Application Diagram.....	3
5.2 Using the module.....	3
6 Pinout / Pin Description.....	4
6.1 Module Pinout.....	4
7 Electrical Characteristics.....	6
7.1 Absolute Maximum Ratings.....	6
7.2 Recommended Operating Conditions	6
7.3 Terminal Characteristics	7
7.4 Radio Characteristics.....	7
7.4.1 Radio Frequencies.....	7
7.4.2 Transmitter.....	7
7.5 ESD Caution Notice.....	8
8 Module Floorplan	8
9 Ordering Information	8
10 Regulatory notes.....	9
10.1 FCC ID.....	10

5 Applications information

5.1 Application Diagram

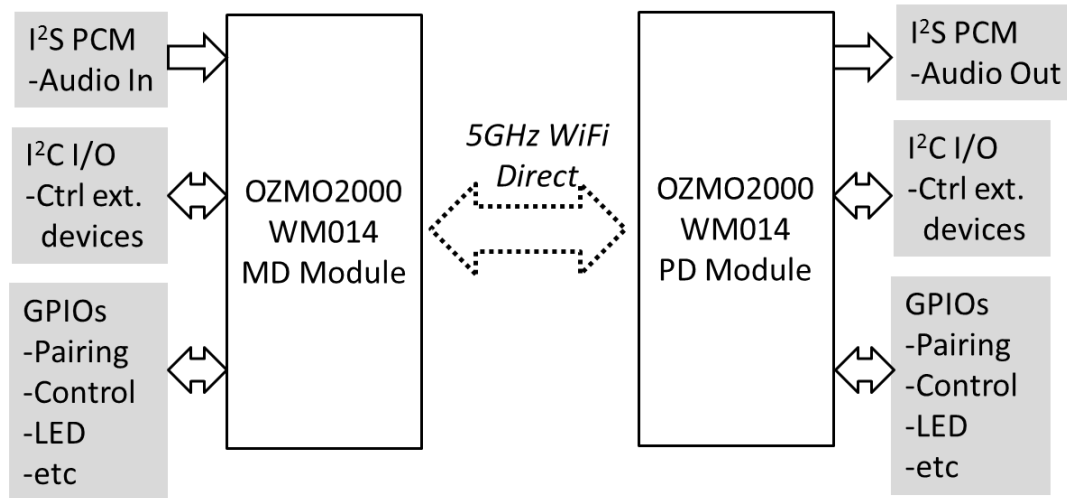

Figure 1 Application Diagram

5.2 Using the module

The WM014 module is designed to operate with customized embedded firmware programmed into the module by Ozmo Devices which controls the functioning of the radio and the various interfaces.

The General Purpose Input-Output pins (referred to as AIO or GPIO pins) are configured and monitored by the firmware.

Depending on the programmed functionality, the module will send data over the wireless link corresponding to the inputs received on the AIO pins, or will output digital signals from the AIO pins based on data received over the wireless link.

Ozmo application engineers will work with customers to define the desired Input-Output behavior and develop the customized firmware to achieve the desired digital input-output behavior. This has no effect on the radio operation which is defined by low-level firmware and hardware and always operates in accordance with FCC and Wi-Fi standards. The custom aspects of the firmware only affect the formatting and timing of the back-end digital I/O functions.

6 Pinout / Pin Description

6.1 Module Pinout

The table below described the pinout and pin descriptions of the module in the default configuration. Pins are numbered 1 to 25 beginning on the left looking at the module from above with the antenna end oriented upward and the row of pins at the bottom

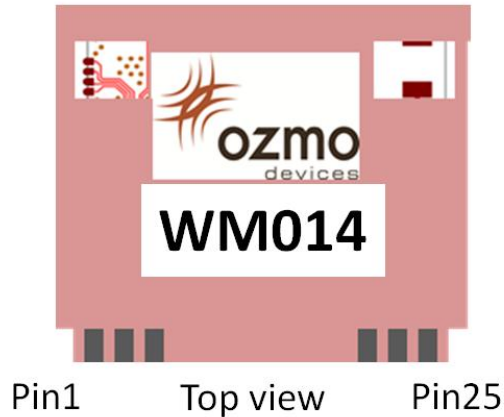

Figure 2 Module Pinout (Top View)

Pin #	MD Module Pin name	MD Pin Description	PD Module Pin name	PD Pin Description
1	VBATT	Power supply	VBATT	Power supply
2	GND		GND	
3	NC		NC	
4	NC		NC	
5	NC		NC	
6	NC		NC	
7	/RESET	Ozmo chip reset	/RESET	Ozmo chip reset
8	NC		NC	
9	NC		NC	

OZMO2000WM014 Module User Guide

Pin #	MD Module Pin name	MD Pin Description	PD Module Pin name	PD Pin Description
10	AIO04 (SDA)	I2C Data	AIO4 (SDA)	I2C Data
11	AIO03 (SCL)	I2C Clock	AIO3 (SCL)	I2C Clock
12	AIO0 (LED1)	GPIO 16mA	AIO0 (LED1)	GPIO 16mA
13	AIO01 (LED2)	GPIO 16mA	AIO1 (LED2)	GPIO 16mA
14	AIO07 (I:Pair)	Input from pairing button on Master system, initiates pairing procedure.	AIO14 (O:DAC Reset)	Output to control peripheral function such as Reset the DAC
15	AIO13	GPIO	AIO13	GPIO
16	AUDIOCLK	Audio clock output	AUDIOCLK	Audio clock output
17	NC		AIO07 (O:MUTE)	Output to control a Peripheral function (such as mute the amplifier)
18	AIO15 (I:GPIO)	GPIO	AIO15 (O:/STBY)	Output to control a Peripheral function (such as place codec in standby)
19	AIO12 (FSYNC)	Audio In Frame Sync (I2S Slave)	AIO9 (FSYNC)	Audio Out Frame Sync (I2S Master)
20	AIO14 (I:/ADCSTBY)	Input indicating system status such as power state	NC	
21	GND		GND	
22	AIO11 (I:PCMIN)	Audio data input	AIO10 (O:PCMOUT)	Audio data output
23	AIO8 (I:PCMCLK)	Audio clock	AIO8 (I:PCMCLK)	Audio clock

Pin #	MD Module Pin name	MD Pin Description	PD Module Pin name	PD Pin Description
24	GND		GND	
25	NC		AIO12 (I:PAIRING/)	Input from pairing button on Peripheral

Figure 3 Module Pinout and Pin Descriptions

7 Electrical Characteristics

7.1 Absolute Maximum Ratings

Parameter	Min	Max	Units
Storage temperature	-40	+125	°C
Supply voltage: V_{BATT}	-0.3	3.6	V
GND	-0.3	0.3	V
Supply voltage: Digital I/O pins	-0.3	$V_{BATT} + 0.3$	V
RF Input Power		+10	dBm

Note: Supply voltage is dependent on ordering option. The on-module flash memory chip can be either a low-voltage or high-voltage type. The default option is for the high voltage type, supply voltage 2.7 to 3.6V.

7.2 Recommended Operating Conditions

Parameter	Min	Typ	Max	Units
Operating temperature	0		+70	°C
Supply voltage: $V_{BATT}^{(1)}$	2.7		3.6	V
GND		0		V

⁽¹⁾ Additional limitations may apply. See ordering information for more detail.

7.3 Terminal Characteristics

Parameter	Conditions	Min	Typ	Max	Units
V_{IL} , input logic low	$1.8 < V_{BATT} < 1.95$	-		$0.3V_{BATT}$	V
V_{IH} , input logic high	$1.8 < V_{BATT} < 1.95$	$0.7V_{BATT}$		-	V
ΔV , input hysteresis			0.4		V
I_i , input resistance	Pull-up resistor to V_{BATT}		42		$k\Omega$
V_{OL} , output logic low	$I_{OL} = 8 \text{ mA}$ (AIO[15:3], TDO, TSTSEL1, AUX0)			$0.2 V_{BATT}$	V
V_{OL} , output logic low	$I_{OL} = 16 \text{ mA}$ (AIO[2:0])			$0.2 V_{BATT}$	V
V_{OH} , output logic high	$I_{OL} = 8 \text{ mA}$ (AIO[15:03], TDO, AUX0)	$0.8 V_{BATT}$			V
V_{OH} , output logic high	$I_{OL} = 16 \text{ mA}$ (AIO[2:0])	$0.8 V_{BATT}$			V
I_{OZ} , output tri-state current	$0.0 \text{ V} < V_o < 3.6 \text{ V}$	-10		10	μA
C_i , input capacitance			5		pF
C_{iO} , input / output capacitance			5		pF

7.4 Radio Characteristics

7.4.1 Radio Frequencies

This module operates on standard Wi-Fi channels within the 5.15GHz to 5.825GHz bands (limited to 5180-5240MHz and 5745-5825MHz for operation in the US). Ozmo Devices will program the module with firmware which automatically selects the channel according to the designated application requirements established with the customer.

7.4.2 Transmitter

The WM014 module is designed to operate at firmware-controlled transmit power levels. The module has been FCC certified at the maximum transmit power settings of +5 dBm (5.150GHz band) and +1 dBm (5.8GHz band). Firmware may be provided to customers which configures the device at lower transmit power levels to achieve longer battery life, but it is not possible to operate this module at any higher power levels than those used during the certification testing.

7.5 ESD Caution Notice



ESD (Electrostatic Discharge) can damage this device. Ozmo, Inc. recommends that all integrated circuits be handled and stored using appropriate ESD precautions. Failure to observe proper procedures can cause ESD damage ranging from performance degradation to complete device failure.

8 Module Floorplan

The diagram below shows the floorplan and dimensions of the OZMO2000WM014 Wireless Module.

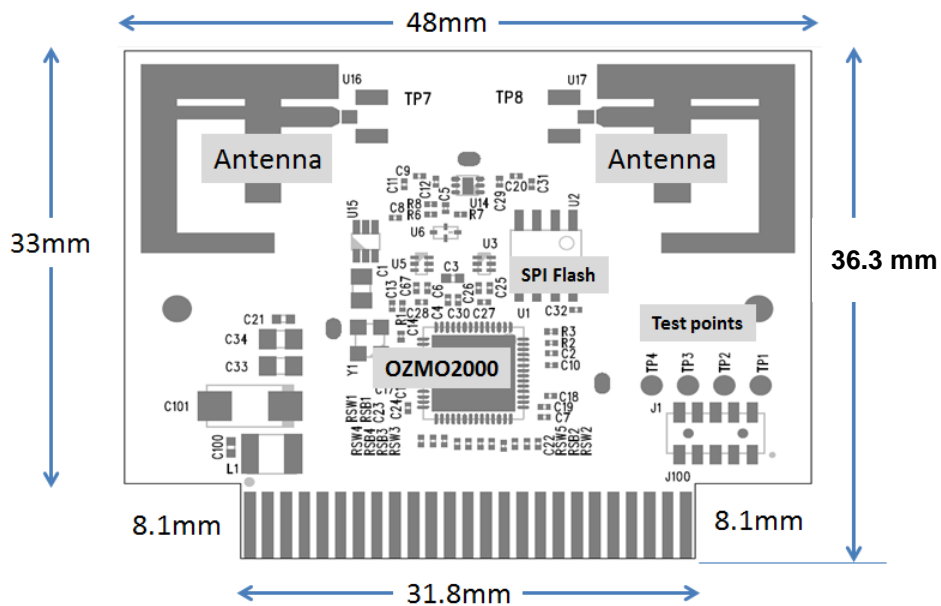

Figure 4 Floorplan of the OZMO2000WM014 Wireless Module

The WM014 module is designed to be mounted to the end-equipment printed circuit board (pcb) either as a card inserted in a slot or laid flat and soldered as a surface mount component. In the latter case standard surface-mount technology (SMT) circuit construction procedures should be followed. For inserting in a slot the pcb is 0.045" thick so the slot should be sized accordingly.

9 Ordering Information

The OZMO2000WM014 wireless module is made available in the following options:

© 2012 Ozmo, Inc. Portions may be covered by one or more of U.S. Patents No. 8,102,871 8,089,982 7,701,271 B1 and 7,826,408 B1. U.S. and foreign patents pending.

OZMO2000WM014 Module User Guide

Order number	Description
OZMO2000WM014-AMH-1321	WM014 Master Device(MD) module: (intended for the master device such as audio base station or TV Soundbar). Single pcb trace antenna integral to the module pcb, referred to as "WM014A1"
OZMO2000WM014-APH-2321	WM014 Peripheral Device(PD) module: (intended for the peripheral device such as cordless headphones or wireless sub-woofer) Dual pcb antenna, referred to as "WM014A2"

Contact your Ozmo sales representative or FAE with further questions or to confirm availability.

10 Regulatory notes

Federal Communication Commission Interference Statement

This equipment has been tested and found to comply with the limits for a Class B digital device, pursuant to Part 15 of the FCC Rules. These limits are designed to provide reasonable protection against harmful interference in a residential installation. This equipment generates uses and can radiate radio frequency energy and, if not installed and used in accordance with the instructions, may cause harmful interference to radio communications. However, there is no guarantee that interference will not occur in a particular installation. If this equipment does cause harmful interference to radio or television reception, which can be determined by turning the equipment off and on, the user is encouraged to try to correct the interference by one of the following measures:

- Reorient or relocate the receiving antenna by moving the end equipment.
- Increase the separation between the equipment and receiver.
- Connect the equipment into an outlet on a circuit different from that to which the receiver is connected.
- Consult the dealer or an experienced radio/TV technician for help.

FCC Caution: To assure continued compliance, (example - use only shielded interface cables when connecting to computer or peripheral devices). Any changes or modifications not expressly approved by the party responsible for compliance could void the user's authority to operate this equipment.

This device complies with Part 15 of the FCC Rules. Operation is subject to the following two conditions: (1) This device may not cause harmful interference, and (2) this device must accept any interference received, including interference that may cause undesired operation.

IMPORTANT NOTE:

FCC & IC Radiation Exposure Statement:

© 2012 Ozmo, Inc. Portions may be covered by one or more of U.S. Patents No. 8,102,871 8,089,982 7,701,271 B1 and 7,826,408 B1. U.S. and foreign patents pending.

OZMO2000WM014 Module User Guide

This equipment complies with FCC & IC radiation exposure limits set forth for an uncontrolled environment.

This transmitter must not be co-located or operating in conjunction with any other antenna or transmitter. This device is intended only for OEM integrators under the following conditions:

- The transmitter module may not be co-located with any other transmitter or antenna.

As long as the condition above is met, further transmitter test will not be required. However, The OEM integrator is still responsible for testing their end-product for any additional compliance requirements required with this module installed (for example, digital device emissions, PC peripheral requirements, etc.).

IMPORTANT NOTE: In the event that these conditions cannot be met (for example certain laptop configurations or co-location with another transmitter), then the FCC & IC authorizations are no longer considered valid and the FCC & IC IDs cannot be used on the final product. In these circumstances, the OEM integrator will be responsible for re-evaluating the end product (including the transmitter) and obtaining separate FCC & IC authorizations.

Indoor usage for 5.2GHz

Important note:

Section 15.407(e) of the FCC Rules states that 5.15 – 5.25 GHz band UNII devices are restricted to **indoor operations**.

If the device is configured for those frequencies, the usage of the device must be restricted to indoor applications.

End Product Labeling

The final end product must be labeled in a visible area with the corresponding FCC ID number. Similar to: “Contains Transmitter Module FCC ID: EFU-OZMO-WM014-A2”

Manual Information That Must be Included

The user’s manual for end users must include the following information in a prominent location.

Warning: modifications of the product not approved by the manufacturer can void the user’s authority to operate the device

The end product using this module must be labeled with the FCC 2part statement

“This device complies with FCC Part 15 of the FCC Rules. Operation is subject to the following two conditions: (1) this device may not cause harmful interference, and (2) this device must accept any interference received, including interference that may cause undesired operation.”

This statement can be placed in the user’s manual if the product is too small.

10.1 FCC ID

This module product has been tested to meet FCC requirements for unlicensed devices and the FCC ID is: EFU-OZMO-WM014-A2

© 2012 Ozmo, Inc. Portions may be covered by one or more of U.S. Patents No. 8,102,871 8,089,982 7,701,271 B1 and 7,826,408 B1. U.S. and foreign patents pending.

OZMO2000WM014 Module User Guide

Example label:

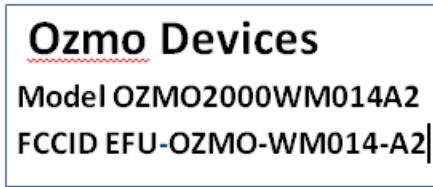

Since this module will be embedded inside other equipment such as consumer audio products, or peripherals like game controllers, that equipment should be marked with a label as follows:

“Contains Transmitter Module FCC ID: EFU-OZMO-WM014-A2”

Document revision history:

1.0	7/2/2012	Initial release
1.1	7/18/2012	Updated part numbers, misc edits
1.2	7/30/2012	Corrected typos