

MiniPCI BG 1W 2.4GHz **XBG24-30**

Features

- IEEE 802.11 b/g standard compliant
- Output Power of up to 30dBm @ b/g Band with built-in ESD Protection
- RF ESD/EMP Immunity Threshold: 15KeV^①
- Supports Atheros Proprietary "Super Mode" delivering up to 108 Mbps data link rate
- Transmission Power Control (IEEE 802.11h TPC)
- Extended distances and high performance due to optimized output signal power
- Multi-Country Roaming Supported (IEEE802.11d Global Harmonization Standard)
- Single MMCX antenna connector allowing for improved mechanical stability and low loss
- Ideal for long-distance, outdoor broadband wireless applications

TECHNICAL SPECIFICATIONS											
Chipset	Atheros 2414										
Host Interface	PCI Interface v2.3 (Type III-B Mini PCI form factor)										
Operating Voltage	3.3 VDC										
Power Consumption	11b Cont. Tx@5.5M	5.0W									
	11g Cont. Tx@6M	5.5W									
	11g Cont. Rx	2.5W									
	Standby	1.5W									
Antenna Connector	1×MMCX (main)										
Data Rates	IEEE 802.11b:	11Mbps	5.5 Mbps	2 Mbps	1 Mbps						
	IEEE 802.11g:	54Mbps	48Mbps	36Mbps	24Mbps	18Mbps	12Mbps	9Mbps	6Mbps		
	Super-G:	108Mbps	96Mbps	72Mbps	54Mbps	48Mbps	36Mbps	24Mbps	18Mbps	12Mbps	6Mbps
Frequency Range	IEEE 802.11b/g:	2.412GHz ~ 2.462GHz (US & Canada)									
		2.412GHz ~ 2.472GHz (Europe)									
		2.412GHz ~ 2.484GHz (Japan)									
Modulation Techniques	OFMD: BPSK, QPSK, 16-QAM, 64-QAM DSSS: DBPSK, DQPSK, CCK										
Certification	FCC										
RoHS Compliance	Yes										
Temperature Range	Operating: -20°C to 70°C Storage: -40 °C to 90 °C										
Humidity	Operating: 5% to 95% (non-condensing) Storage: Max.90% (non-condensing)										
Dimensions	64.3 mm x 47 mm x 14 mm										

XBG24-30 MINIPCI CARD RADIO SPECIFICATIONS							
TX SPECIFICATIONS				RX SPECIFICATIONS			
	DataRate	TX Power	Tolerance		DataRate	Sensitivity	Tolerance
802.11b	1Mbps	30dBm	+1.0/-1.5 dB	802.11b	1Mbps	-96dBm	±2dB
	2Mbps	30dBm	+1.0/-1.5 dB		2Mbps	-93dBm	±2dB
	5.5Mbps	30dBm	+1.0/-1.5 dB		5.5Mbps	-91dBm	±2dB
	11Mbps	30dBm	+1.0/-1.5 dB		11Mbps	-90dBm	±2dB
802.11g	6Mbps	30dBm	+1.0/-1.5 dB	802.11g	6Mbps	-93dBm	±2dB
	9Mbps	30dBm	+1.0/-1.5 dB		9Mbps	-90dBm	±2dB
	12Mbps	30dBm	+1.0/-1.5 dB		12Mbps	-89dBm	±2dB
	18Mbps	30dBm	+1.0/-1.5 dB		18Mbps	-87dBm	±2dB
	24Mbps	30dBm	+1.0/-1.5 dB		24Mbps	-84dBm	±2dB
	36Mbps	28dBm	+1.0/-1.5 dB		36Mbps	-80dBm	±2dB
	48Mbps	27dBm	+1.0/-1.5 dB		48Mbps	-76dBm	±2dB
	54Mbps	25dBm	+1.0/-1.5 dB		54Mbps	-74dBm	±2dB

ESD CABLE SPECIFICATIONS	
Physical Dimensions	26cm length
Terminal Material	Copper
Attachment Procedure	End of ESD Cable tied to Earth Ground

ORDERING INFORMATION^②

CODES	SPEED	Carton Dimensions
XBG24-30	Up to 108 Mbps	For 50pcs (pcs/ctn), 0.40m * 0.22m * 0.085m / 0.006 = 1.5KG

- ① Comes with grounding cable
- ② Configurations are subject to change without notice

DIMENSIONS DRAWING

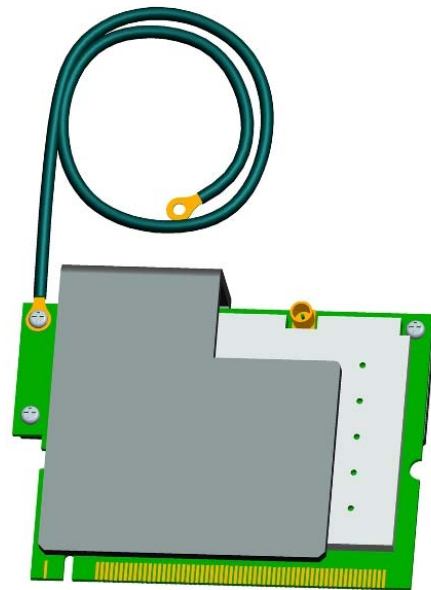
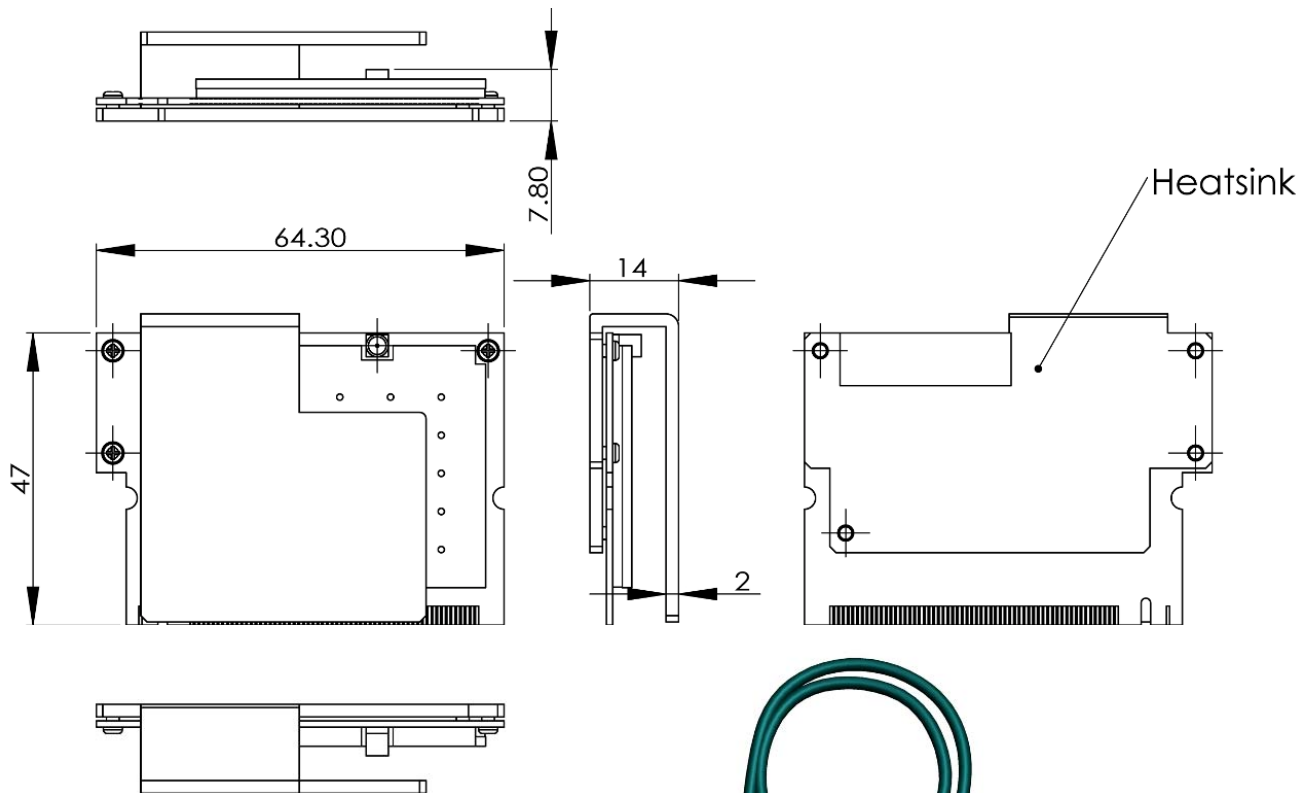

Compliance Information

FCC Compliance Statement:

This device complies with Part 15 of the FCC Rules . Operation is subject to the following two conditions:

1. This device may not cause harmful interference, and
2. This device must accept any interference received, including interference that may cause undesired operation. This device must accept any interference received, including interference that may cause undesired operation. Product that is a radio transmitter is labeled with FCC ID.

FCC Caution:

(1) Exposure to Radio Frequency Radiation. This equipment must be installed and operated in accordance with provided instructions and the antenna(s) used for this transmitter must be installed to provide a separation distance of at least 20 cm from all persons and must not be collocated or operating in conjunction with any other antenna or transmitter. End-users and installers must be provided with antenna installation instructions and transmitter operating conditions for satisfying RF exposure compliance.

(2) Any changes or modifications not expressly approved by the grantee of this device could void the user's authority to operate the equipment.

(3) This Transmitter must not be co-located or operating in conjunction with any other antenna or transmitter.

(4) Changes or modifications to this unit not expressly approved by the party responsible for compliance could void the user authority to operate the equipment.

NOTE:

(1) This device is approved for OEM installation with specified antennas as listed in this Manual. It is the responsibility of the Installer to comply with the separation distance for satisfying RF exposure compliance.

IMPORTANT NOTE: In the event that these conditions can not be met (for example certain laptop configurations or co-location with another transmitter), then the FCC authorization is no longer considered valid and the FCC ID can not be used on the final product. In these circumstances, the OEM integrator will be responsible for re-evaluating the end product (including the transmitter) and obtaining a separate FCC authorization.

IC Radiation Exposure Statement for Canada:

This device complies with Industry Canada licence-exempt RSS standard(s).

Operation is subject to the following two conditions:

- (1) this device may not cause interference,
- (2) this device must accept any interference, including interference that may cause undesired operation of the device.

Le présent appareil est conforme aux CNR d'Industrie Canada applicables aux appareils radio exempts de licence.

L'exploitation est autorisée aux deux conditions suivantes :

- (1) l'appareil ne doit pas produire de brouillage, et
- (2) l'utilisateur de l'appareil doit accepter tout brouillage radioélectrique subi, même si le brouillage est susceptible d'en compromettre le fonctionnement.

Under Industry Canada regulations, this radio transmitter may only operate using an antenna of a type and maximum (or lesser) gain approved for the transmitter by Industry Canada. To reduce potential radio interference to other users, the antenna type and its gain should be so chosen that the equivalent isotropically radiated power (e.i.r.p.) is not more than that necessary for successful communication.

This radio transmitter (identify the device by certification number, or model number if Category II) has been approved by Industry Canada to operate with the antenna types listed below with the maximum permissible gain and required antenna impedance for each antenna type indicated. Antenna types not included in this list, having a gain greater than the maximum gain indicated for that type, are strictly prohibited for use with this device.

- (1) the modules FCC ID is not visible when installed in the host, or**
 - (2) if the host is marketed so that end users do not have straightforward commonly used methods for access to remove the module so that the FCC ID of the module is visible;**
- then an additional permanent label referring to the enclosed module: Contains**

Transmitter Module

FCC ID : NS912XBG24-30

or Contains FCC ID: NS912XBG24-30 must be used.

Microhard Systems Inc

Address: 150 Country Hills Landing NW Calgary Alberta Canada

Contact Name: Hany Shenouda

Tel. No: 403-248-0028

Fax No: 403-248-2762

Email: shenouda@microhardcorp.com