

User's Guide  
For  
Wifi module

Model Number: WUS-N26

Revision: 1.3

# Revision History

---

Rev.	Date	Author	Reason for Changes
1.0	April 11, 2011	Lena Chen	<ul style="list-style-type: none"><li>• initial</li></ul>
1.1	April 19, 2011	Lena Chen	<ul style="list-style-type: none"><li>• modify TX power and RX sensitivity</li></ul>
1.2	June 21, 2011	Lena Chen	<ul style="list-style-type: none"><li>• modify length and width in 2.3 Mechanical Requirement</li><li>• add board outline in 2,3 Mechanical Requirement</li><li>• modify TX power value and RX sensitivity</li><li>• add power consumption information</li></ul>
1.3	September 19 , 2011	Lena Chen	<ul style="list-style-type: none"><li>• modify TX power value in 2.2.1.7 , 2.2.2.7 and 2.2.3.6</li><li>• add temperature range of operating temperature conditions in 2.5.1</li></ul>

## Contents

INSTALLATION GUIDE .....	03
1.1 DOCUMENT.....	13
1.2 PRODUCT FEATURES.....	13
2.1 FUNCTIONAL BLOCK DIAGRAM.....	14
2.2 GENERAL REQUIREMENTS .....	14
2.2.1 IEEE 802.11b Section.....	14
2.2.2 IEEE 802.11g Section.....	14
2.2.3 IEEE 802.11 final n Section .....	15
2.2.4 General Section .....	16
2.3 MECHANICAL REQUIREMENTS.....	16
2.4 REQUIREMENTS OF RELIABILITY, MAINTAINABILITY AND QUALITY .....	16
2.5 ENVIRONMENTAL REQUIREMENTS .....	17
2.6 REGULATORY .....	17

# Installation Guide

Please follow below indication to setup WUS-N-26 devices.

```
*****  
; RT2870QA.inf  
; This installation script supports 2000 & XP for the  
; Ralink UsbDumpr_RT2870 series Wireless LAN Card.  
; Copyright (c)2002 ~ 2011, Ralink Technology Corp., All Rights Reserved  
; All Rights Reserved.  
; Developed by RaLink Technology, Corp. -- http://www.ralinktech.com  
*****
```

```
[Version]  
DriverVer=03/18/2011, 1.00.07.0000  
Signature="$Chicago$"  
Compatible=1  
Class=Net  
ClassGUID={4d36e972-e325-11ce-bfc1-08002be10318}  
Provider=%Provider%  
;CatalogFile=UsbDumpr_RT2870.CAT ;;for WHQL certified
```

```
[ControlFlags]  
  
;*****Ralink 802.11b board *****  
ExcludeFromSelect = USB\VID_148F&PID_2870  
ExcludeFromSelect = USB\VID_18E8&PID_6196
```

```
[Manufacturer]  
%V_Provider%=Adapters
```

```
[Adapters]  
; DisplayName            Section            DeviceID  
; -----            -----            -----  
%UsbDumpr_RT2870.DeviceDesc% =UsbDumpr_RT2870.ndi,    USB\VID_148F&PID_2870  
%UsbDumpr_RT2770.DeviceDesc% =UsbDumpr_RT2870.ndi,    USB\VID_148F&PID_2770  
%UsbDumpr_RT3070.DeviceDesc% =UsbDumpr_RT2870.ndi,    USB\VID_148F&PID_3070  
%UsbDumpr_RT3071.DeviceDesc% =UsbDumpr_RT2870.ndi,    USB\VID_148F&PID_3071  
%UsbDumpr_RT3072.DeviceDesc% =UsbDumpr_RT2870.ndi,    USB\VID_148F&PID_3072  
%UsbDumpr_RT2070.DeviceDesc% =UsbDumpr_RT2870.ndi,    USB\VID_148F&PID_2070
```

```
%UsbDumpr_RT3572.DeviceDesc% =UsbDumpr_RT2870.ndi, USB\VID_148F&PID_3572
%UsbDumpr_RT3370.DeviceDesc% =UsbDumpr_RT2870.ndi, USB\VID_148F&PID_3370
%UsbDumpr_RT3573.DeviceDesc% =UsbDumpr_RT2870.ndi, USB\VID_148F&PID_3573
%UsbDumpr_RT8070.DeviceDesc% =UsbDumpr_RT2870.ndi, USB\VID_148F&PID_8070
%UsbDumpr_RT5370.DeviceDesc% =UsbDumpr_RT2870.ndi, USB\VID_148F&PID_5370
%UsbDumpr_RT5372.DeviceDesc% =UsbDumpr_RT2870.ndi, USB\VID_148F&PID_5372
%UsbDumpr_RT5572.DeviceDesc% =UsbDumpr_RT2870.ndi, USB\VID_148F&PID_5572
```

```
*****
```

```
; Windows 9X specific entries
```

```
*****
```

```
[UsbDumpr_RT2870.ndi]
```

```
AddReg=Common.reg, UsbDumpr_RT2870.ndi.reg
```

```
CopyFiles=win9x.CopyFiles
```

```
*****
```

```
; NT specific entries
```

```
*****
```

```
[UsbDumpr_RT2870.ndi.NT]
```

```
AddReg=Common.reg, UsbDumpr_RT2870.ndi.NT.reg
```

```
Characteristics=0x84 ; NCF_REMOVABLE | NCF_HAS_UI | NCF_PHYSICAL
```

```
BusType=5
```

```
CopyFiles=NT.CopyFiles
```

```
; NT services sections
```

```
[UsbDumpr_RT2870.ndi.NT.Services]
```

```
AddService=UsbDumpr_RT2870, 2, UsbDumpr_RT2870.Service, common.EventLog
```

```
[UsbDumpr_RT2870.ndi.reg]
```

```
HKR, , NTMPDriver, 0, RT2870QA.sys
```

```
HKR, Ndi, DeviceID, 0, "USB\VID_148F&PID_2870"
```

```
HKR, , RunningWin9X, 0, "1"
```

```
HKR, , DevLoader, 0, *ndis
```

```
HKR, , DeviceVxDs, 0, RT2870QA.sys
```

```
HKR, , EnumPropPages, 0, "netdi.dll,EnumPropPages"
```

```
;
; NDIS Info
;
HKR, NDIS,          LogDriverName, 0, "UsbDumpr_RT2870"
HKR, NDIS,          MajorNdisVersion,1, 03
HKR, NDIS,          MinorNdisVersion,1, 0A
```

```
HKR, ,              BusType,      0, 5
HKR, NDI,           CardType,     0, "PCI"
```

```
;
; Interfaces
```

```
HKR, Ndi\Interfaces, DefUpper,    0, "ndis3"
HKR, Ndi\Interfaces, DefLower,    0, "ethernet"
HKR, Ndi\Interfaces, UpperRange,   0, "ndis3"
HKR, Ndi\Interfaces, LowerRange,   0, "ethernet"
```

```
;
; Install sections
;HKR,Ndi\Install,ndis3,,"UsbDumpr_RT2870.install"
```

```
[win9x.CopyFiles]
RT2870QA.sys ; Win9x Installation
```

```
;*****
; common regs for NT and W9x
;*****
HKR,"Parameters","MaximumTransferSize",0x10001,4096
HKR,"Parameters","DebugLevel",0x10001,2
HKR,"Parameters","BulkUsbEnable",0x10001,1
```

```
;*****
; DestinationDirs
;*****
[DestinationDirs]
NT.CopyFiles=12 ; system32\drivers subdirectory on NT
win9x.CopyFiles=11 ; system32 subdirectory on win9x
```

```
[NT.CopyFiles]
```

RT2870QA.sys ; NT Installation  
;RT2870.bin ; Binary file of firmware

[SourceDisksNames]

1=%INSTALL\_DISK\_STR%,,,

[SourceDisksFiles]

RT2870QA.sys=1

;\*\*\*\*\*

; NT specific

;\*\*\*\*\*

[UsbDumpr\_RT2870.ndi.NT.reg]

HKR, Ndi, Service, 0, "UsbDumpr\_RT2870"

HKR, Ndi\Interfaces, UpperRange, 0, "ndis5"

HKR, Ndi\Interfaces, LowerRange, 0, "ethernet"

[UsbDumpr\_RT2870.Service]

DisplayName=%UsbDumpr\_RT2870.Service.DispName%

ServiceType=1 ;%SERVICE\_KERNEL\_DRIVER%

StartType=3 ;%SERVICE\_AUTO\_START%

ErrorControl=1 ;%SERVICE\_ERROR\_NORMAL%

ServiceBinary=%12%\RT2870QA.sys

LoadOrderGroup=NDIS

[common.EventLog]

AddReg=common.AddEventLog.reg

[common.AddEventLog.reg]

HKR, , EventMessageFile,  
0x00020000,"%%SystemRoot%%\System32\netevent.dll,%%SystemRoot%%\System32\drivers\RT2870QA.sys"

HKR, , TypesSupported, 0x00010001, 7

;\*\*\*\*\*

; Strings

;\*\*\*\*\*

[strings]

Provider= "Ralink"

V\_Provider= "Ralink Technology Corp."

UsbDumpr\_RT2870.DeviceDesc= "RT2870 QATest USB WDM Driver"

UsbDumpr\_RT2770.DeviceDesc= "RT2770 QATest USB WDM Driver"

UsbDumpr\_RT3070.DeviceDesc= "RT3070 QATest USB WDM Driver"

UsbDumpr\_RT3071.DeviceDesc= "RT3071 QATest USB WDM Driver"

UsbDumpr\_RT3072.DeviceDesc= "RT3072 QATest USB WDM Driver"

UsbDumpr\_RT2070.DeviceDesc= "RT2070 QATest USB WDM Driver"

UsbDumpr\_RT3572.DeviceDesc= "RT3572 QATest USB WDM Driver"

UsbDumpr\_RT3370.DeviceDesc= "RT3370 QATest USB WDM Driver"

UsbDumpr\_RT3573.DeviceDesc= "RT3573 QATest USB WDM Driver"

UsbDumpr\_RT8070.DeviceDesc= "RT8070 QATest USB WDM Driver"

UsbDumpr\_RT5370.DeviceDesc= "RT5370 QATest USB WDM Driver"

UsbDumpr\_RT5372.DeviceDesc= "RT5372 QATest USB WDM Driver"

UsbDumpr\_RT5572.DeviceDesc= "RT5572 QATest USB WDM Driver"

UsbDumpr\_RT2870.Service.DispName= "RT2870 QATest USB WDM Driver Service"

INSTALL\_DISK\_STR= "RT2870 QATest Wireless LAN Installation Disk"





## Federal Communication Commission Interference Statement

This device complies with Part 15 of the FCC Rules. Operation is subject to the following two conditions: (1) This device may not cause harmful interference, and (2) this device must accept any interference received, including interference that may cause undesired operation.

This equipment has been tested and found to comply with the limits for a Class B digital device, pursuant to Part 15 of the FCC Rules. These limits are designed to provide reasonable protection against harmful interference in a residential installation. This equipment generates, uses and can radiate radio frequency energy and, if not installed and used in accordance with the instructions, may cause harmful interference to radio communications. However, there is no guarantee that interference will not occur in a particular installation. If this equipment does cause harmful interference to radio or television reception, which can be determined by turning the equipment off and on, the user is encouraged to try to correct the interference by one of the following measures:

- Reorient or relocate the receiving antenna.
- Increase the separation between the equipment and receiver.
- Connect the equipment into an outlet on a circuit different from that to which the receiver is connected.
- Consult the dealer or an experienced radio/TV technician for help.

FCC Caution: Any changes or modifications not expressly approved by the party responsible for compliance could void the user's authority to operate this equipment.

This transmitter must not be co-located or operating in conjunction with any other antenna or transmitter.

### **Radiation Exposure Statement:**

This equipment complies with FCC radiation exposure limits set forth for an uncontrolled environment. This equipment should be installed and operated with minimum distance 20cm between the radiator & your body.

### **This device is intended only for OEM integrators under the following conditions:**

- 1) The antenna must be installed such that 20 cm is maintained between the antenna and users, and
- 2) The transmitter module may not be co-located with any other transmitter or antenna.

As long as 2 conditions above are met, further transmitter test will not be required. However, the OEM integrator is still responsible for testing their end-product for any additional compliance requirements required with this module installed

**IMPORTANT NOTE:** In the event that these conditions can not be met (for example certain laptop configurations or co-location with another transmitter), then the FCC authorization is no longer considered valid and the FCC ID can not be used on the final product. In these circumstances, the OEM integrator will be responsible for re-evaluating the end product (including the transmitter) and obtaining a separate FCC authorization.

### **End Product Labeling**

This transmitter module is authorized only for use in device where the antenna may be installed such that 20 cm may be maintained between the antenna and users. The final end product must be labeled in a visible area with the following: "Contains FCC ID: RRK-WUSN26". The grantee's FCC ID can be used only when all FCC compliance requirements are met.

### **Manual Information To the End User**

The OEM integrator has to be aware not to provide information to the end user regarding how to install or remove this RF module in the user's manual of the end product which integrates this module. The end user manual shall include all required regulatory information/warning as show in this manual.



#### **Industry Canada statement:**

This device complies with RSS-210 of the Industry Canada Rules. Operation is subject to the following two conditions: (1) This device may not cause harmful interference, and (2) this device must accept any interference received, including interference that may cause undesired operation.

Ce dispositif est conforme à la norme CNR-210 d'Industrie Canada applicable aux appareils radio exempts de licence. Son fonctionnement est sujet aux deux conditions suivantes: (1) le dispositif ne doit pas produire de brouillage préjudiciable, et (2) ce dispositif doit accepter tout brouillage reçu, y compris un brouillage susceptible de provoquer un fonctionnement indésirable.

#### **Radiation Exposure Statement:**

This equipment complies with IC radiation exposure limits set forth for an uncontrolled environment. This equipment should be installed and operated with minimum distance 20cm between the radiator & your body.

#### **Déclaration d'exposition aux radiations:**

Cet équipement est conforme aux limites d'exposition aux rayonnements IC établies pour un environnement non contrôlé. Cet équipement doit être installé et utilisé avec un minimum de 20 cm de distance entre la source de rayonnement et votre corps.

This device is intended only for OEM integrators under the following conditions: (For module device use)

- 1) The antenna must be installed such that 20 cm is maintained between the antenna and users, and
- 2) The transmitter module may not be co-located with any other transmitter or antenna.

As long as 2 conditions above are met, further transmitter test will not be required. However, the OEM integrator is still responsible for testing their end-product for any additional compliance requirements required with this module installed.

#### **Cet appareil est conçu uniquement pour les intégrateurs OEM dans les conditions suivantes: (Pour utilisation de dispositif module)**

- 1) L'antenne doit être installée de telle sorte qu'une distance de 20 cm est respectée entre l'antenne et les utilisateurs, et
- 2) Le module émetteur peut ne pas être coimplanté avec un autre émetteur ou antenne.

Tant que les 2 conditions ci-dessus sont remplies, des essais supplémentaires sur l'émetteur ne seront pas nécessaires. Toutefois, l'intégrateur OEM est toujours responsable des essais sur son produit final pour toutes exigences de conformité supplémentaires requis pour ce module installé.

**IMPORTANT NOTE:**

In the event that these conditions can not be met (for example certain laptop configurations or co-location with another transmitter), then the Canada authorization is no longer considered valid and the IC ID can not be used on the final product. In these circumstances, the OEM integrator will be responsible for re-evaluating the end product (including the transmitter) and obtaining a separate Canada authorization.

**NOTE IMPORTANTE:**

Dans le cas où ces conditions ne peuvent être satisfaites (par exemple pour certaines configurations d'ordinateur portable ou de certaines co-localisation avec un autre émetteur), l'autorisation du Canada n'est plus considéré comme valide et l'ID IC ne peut pas être utilisé sur le produit final. Dans ces circonstances, l'intégrateur OEM sera chargé de réévaluer le produit final (y compris l'émetteur) et l'obtention d'une autorisation distincte au Canada.

**End Product Labeling**

This transmitter module is authorized only for use in device where the antenna may be installed such that 20 cm may be maintained between the antenna and users. The final end product must be labeled in a visible area with the following: "Contains IC: 4833A-WUSN26".

**Plaque signalétique du produit final**

Ce module émetteur est autorisé uniquement pour une utilisation dans un dispositif où l'antenne peut être installée de telle sorte qu'une distance de 20cm peut être maintenue entre l'antenne et les utilisateurs. Le produit final doit être étiqueté dans un endroit visible avec l'inscription suivante: "Contient des IC: 4833A-WUSN26".

**Manual Information To the End User**

The OEM integrator has to be aware not to provide information to the end user regarding how to install or remove this RF module in the user's manual of the end product which integrates this module.

The end user manual shall include all required regulatory information/warning as show in this manual.

**Manuel d'information à l'utilisateur final**

L'intégrateur OEM doit être conscient de ne pas fournir des informations à l'utilisateur final quant à la façon d'installer ou de supprimer ce module RF dans le manuel de l'utilisateur du produit final qui intègre ce module. Le manuel de l'utilisateur final doit inclure toutes les informations réglementaires requises et avertissements comme indiqué dans ce manuel.

## Europe – EU Declaration of Conformity

This device complies with the essential requirements of the R&TTE Directive 1999/5/EC. The following test methods have been applied in order to prove presumption of conformity with the essential requirements of the R&TTE Directive 1999/5/EC:

EN 55022: 2010/ EN 55024: 2010  
EN 301 489-1 V1.8.1 (2008-04) / EN 301 489-17 V2.1.1 (2009-05)  
EN 300 328 V1.7.1: 2006  
EN 62311: 2008  
EN 60950-1 :2006 + A11:2009

This device is a 2.4 GHz wideband transmission system (transceiver), intended for use in all EU member states and EFTA countries, except in France and Italy where restrictive use applies.

In Italy the end-user should apply for a license at the national spectrum authorities in order to obtain authorization to use the device for setting up outdoor radio links and/or for supplying public access to telecommunications and/or network services.

This device may not be used for setting up outdoor radio links in France and in some areas the RF output power may be limited to 10 mW EIRP in the frequency range of 2454 – 2483.5 MHz. For detailed information the end-user should contact the national spectrum authority in France.

# ALPHA

# CE 0081

<b>cs</b> Český [Czech]	[ <i>Jméno výrobce</i> ] tímto prohlašuje, že tento [ <i>typ zařízení</i> ] je ve shodě se základními požadavky a dalšími příslušnými ustanoveními směrnice 1999/5/ES.
<b>da</b> Dansk [Danish]	Undertegnede [ <i>fabrikantens navn</i> ] erklærer herved, at følgende udstyr [ <i>udstyrets typebetegnelse</i> ] overholder de væsentlige krav og øvrige relevante krav i direktiv 1999/5/EF.
<b>de</b> Deutsch [German]	Hiermit erkläre [ <i>Name des Herstellers</i> ], dass sich das Gerät [ <i>Gerätetyp</i> ] in Übereinstimmung mit den grundlegenden Anforderungen und den übrigen einschlägigen Bestimmungen der Richtlinie 1999/5/EG befindet.
<b>et</b> Eesti [Estonian]	Käesolevaga kinnitab [ <i>tootja nimi = name of manufacturer</i> ] seadme [ <i>seadme tüüp = type of equipment</i> ] vastavust direktiivi 1999/5/EÜ põhinõuetele ja nimetatud direktiivist tulenevatele teistele asjakohastele sätetele.
<b>en</b> English	Hereby, [ <i>name of manufacturer</i> ], declares that this [ <i>type of equipment</i> ] is in compliance with the essential requirements and other relevant provisions of Directive 1999/5/CE.
<b>es</b> Español [Spanish]	Por medio de la presente [ <i>nombre del fabricante</i> ] declara que el [ <i>clase de equipo</i> ] cumple con los requisitos esenciales y cualesquiera otras disposiciones aplicables o exigibles de la Directiva 1999/5/CE.
<b>el</b> Ελληνική [Greek]	ΜΕ ΤΗΝ ΠΑΡΟΥΣΑ [ <i>name of manufacturer</i> ] ΔΗΛΩΝΕΙ ΟΤΙ [ <i>type of equipment</i> ] ΣΥΜΜΟΡΦΩΝΕΤΑΙ ΠΡΟΣ ΤΙΣ ΟΥΣΙΩΔΕΙΣ ΑΠΑΙΤΗΣΕΙΣ ΚΑΙ ΤΙΣ ΛΟΙΠΕΣ ΣΧΕΤΙΚΕΣ ΔΙΑΤΑΞΕΙΣ ΤΗΣ ΟΔΗΓΙΑΣ 1999/5/ΕΚ.
<b>fr</b> Français [French]	Par la présente [ <i>nom du fabricant</i> ] déclare que l'appareil [ <i>type d'appareil</i> ] est conforme aux exigences essentielles et aux autres dispositions pertinentes de la directive 1999/5/CE.
<b>it</b> Italiano [Italian]	Con la presente [ <i>nome del costruttore</i> ] dichiara che questo [ <i>tipo di apparecchio</i> ] è conforme ai requisiti essenziali ed alle altre disposizioni pertinenti stabilite dalla direttiva 1999/5/CE.
Latviski [Latvian]	Ar šo [ <i>name of manufacturer / izgatavotāja nosaukums</i> ] deklarē, ka [ <i>type of equipment / iekārtas tips</i> ] atbilst Direktīvas 1999/5/EK būtiskajām prasībām un citiem ar to saistītajiem noteikumiem.
Lietuvių [Lithuanian]	Šiuo [ <i>manufacturer name</i> ] deklaruoją, kad šis [ <i>equipment type</i> ] atitinka esminius reikalavimus ir kitas 1999/5/EB Direktyvos nuostatas.
<b>nl</b> Nederlands [Dutch]	Hierbij verklaart [ <i>naam van de fabrikant</i> ] dat het toestel [ <i>type van toestel</i> ] in overeenstemming is met de essentiële eisen en de andere relevante bepalingen van richtlijn 1999/5/EG.
<b>mt</b> Malti [Maltese]	Hawnhekk, [ <i>isem tal-manifattur</i> ], jiddikjara li dan [ <i>il-mudell tal-prodott</i> ] jikkonforma mal-ftiġġiet essenzjali u ma provvedimenti oħrajn rilevanti li hemm fid-Dirrettiva 1999/5/CE.
<b>hu</b> Magyar [Hungarian]	Alulírott, [ <i>gyártó neve</i> ] nyilatkozom, hogy a [ <i>... típus</i> ] megfelel a vonatkozó alapvető követelményeknek és az 1999/5/EC irányelv egyéb előírásainak.
<b>pl</b> Polski [Polish]	Niniejszym [ <i>nazwa producenta</i> ] oświadczam, że [ <i>nazwa wyrobu</i> ] jest zgodny z zasadniczymi wymogami oraz pozostałymi stosownymi postanowieniami Dyrektywy 1999/5/EC.
<b>pt</b> Português [Portuguese]	[ <i>Nome do fabricante</i> ] declara que este [ <i>tipo de equipamento</i> ] está conforme com os requisitos essenciais e outras disposições da Directiva 1999/5/CE.
<b>sl</b> Slovensko [Slovenian]	[ <i>Ime proizvajalca</i> ] izjavlja, da je ta [ <i>tip opreme</i> ] v skladu z bistvenimi zahtevami in ostalimi relevantnimi določili direktive 1999/5/ES.
Slovenský [Slovak]	[ <i>Meno výrobcu</i> ] týmto vyhlasuje, že [ <i>typ zariadenia</i> ] spĺňa základné požiadavky a všetky príslušné ustanovenia Smernice 1999/5/ES.
<b>fi</b> Suomi [Finnish]	[ <i>Valmistaja = manufacturer</i> ] vakuuttaa täten että [ <i>type of equipment = laitteen tyyppimerkintä</i> ] tyyppinen laite on direktiivin 1999/5/EY oleellisten vaatimusten ja sitä koskevien direktiivin muiden ehtojen mukainen.
<b>sv</b> Svenska [Swedish]	Härmed intygar [ <i>företag</i> ] att denna [ <i>utrustningstyp</i> ] står i överensstämmelse med de väsentliga egenskapskrav och övriga relevanta bestämmelser som framgår av direktiv 1999/5/EG.



## 1.0 Scope

### 1.1 Document

This document is to specify the product requirements for **Wifi module**. This Card is based on Ralink chipset that complied with IEEE 802.11b, IEEE 802.11g, IEEE 802.11n standard from 2.400~2.4835GHz, and it can be used to provide up to 54Mbps for 802.11g, 11Mbps for 802.11b and 150Mbps for 802.11n to connect your wireless LAN.

With seamless roaming, fully interoperability and advanced security with WEP standard, **Wifi module** offers absolute interoperability with different vendors' 802.11g, 802.11b and 802.11n Access Points through the wireless LAN.

### 1.2 Product Features

- Compatible with IEEE 802.11n draft standard to provide wireless 150Mbps data rate.
- Compatible with IEEE 802.11g standard to provide wireless 54Mbps data rate
- Compatible with IEEE 802.11b standard to provide wireless 11Mbps data rate
- Operation at 2.400 ~ 2.835GHz frequency band to meet worldwide regulations
- Dynamic data rate scaling at 6, 9, 12, 18, 24, 36, 48, 54 for IEEE 802.11g.
- Dynamic data rate scaling at 1, 2, 5.5, and 11Mbps for IEEE 802.11b
- Maximum reliability, throughput and connectivity with automatic data rate switching
- Support wireless data encryption with 64/128-bit WEP for security
- Support WEP, 802.1x, WPA and WPA2 enhanced security
- High speed USB 2.0 interface
- RoHS compliant
- Integrated antenna

The following sections identify the detailed requirements of the **Wifi module**.

### 2.1 Functional Block Diagram

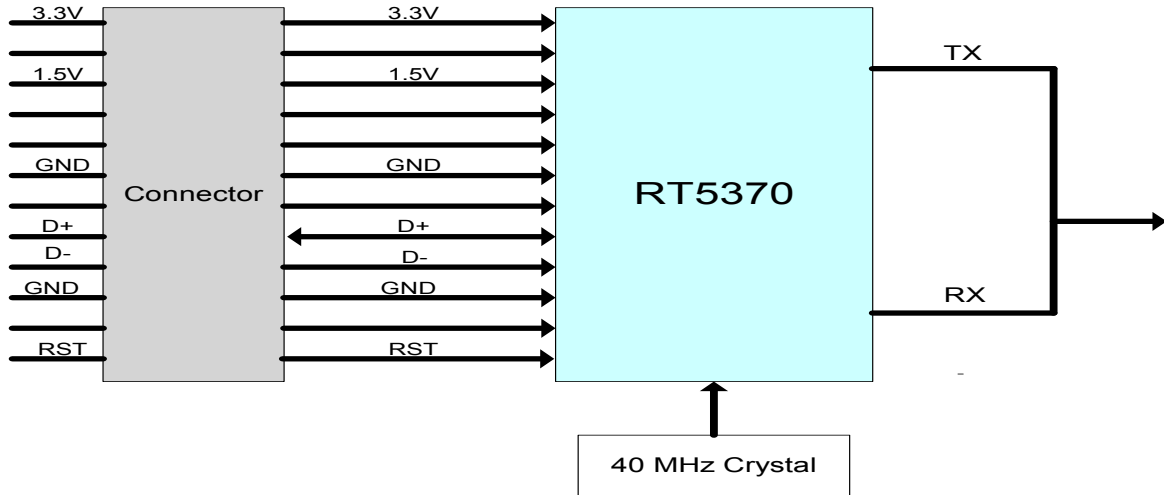

### 2.2 General Requirements

#### 2.2.1 IEEE 802.11b Section

#	Feature	Detailed Description
2.2.1.1	Standard	<ul style="list-style-type: none"> <li>IEEE 802.11b</li> </ul>
2.2.1.2	Radio and Modulation Schemes	<ul style="list-style-type: none"> <li>DQPSK, DBPSK, DSSS, and CCK</li> </ul>
2.2.1.3	Operating Frequency	<ul style="list-style-type: none"> <li>2400 ~ 2483.5MHz ISM band</li> </ul>
2.2.1.4	Channel Numbers	<ul style="list-style-type: none"> <li>11 channels for United States/ Canada</li> <li>13 channels for Europe Countries</li> <li>13 channels for Japan</li> </ul>
2.2.1.5	Data Rate	<ul style="list-style-type: none"> <li>11, 5.5, 2, and 1Mbps</li> </ul>
2.2.1.6	Media Access Protocol	<ul style="list-style-type: none"> <li>CSMA/CA with ACK</li> </ul>
2.2.1.7	Transmitter Output Power before Antenna	<ul style="list-style-type: none"> <li>Typical RF Output Power (tolerance : <math>\pm 2</math> dBm) and Data Rate at each RF chain, at room Temp. 25degree C</li> <li>10 dBm</li> </ul>
2.2.1.8	Receiver Sensitivity before Antenna	<ul style="list-style-type: none"> <li>Typical Sensitivity at Which Frame (1000-byte PDUs) Error Rate = 10%</li> <li>-89 dBm at 1Mbps</li> <li>-86 dBm at 2Mbps</li> <li>-85 dBm at 5.5Mbps</li> <li>-76 dBm at 11Mbps</li> </ul>

#### 2.2.2 IEEE 802.11g Section

#	Feature	Detailed Description
2.2.2.1	Standard	<ul style="list-style-type: none"> <li>IEEE 802.11g</li> </ul>
2.2.2.2	Radio and Modulation Type	<ul style="list-style-type: none"> <li>BPSK, QPSK, 16QAM, 64QAM with OFDM</li> </ul>
2.2.2.3	Operating Frequency	<ul style="list-style-type: none"> <li>2400 ~ 2483.5MHz ISM band</li> </ul>



#	Feature	Detailed Description
2.2.2.4	Channel Numbers	<ul style="list-style-type: none"> <li>11 channels for United States/ Canada</li> <li>13 channels for Europe Countries</li> <li>13 channels for Japan</li> </ul>
2.2.2.5	Data Rate	<ul style="list-style-type: none"> <li>6,9,12,18,24,36,48,54Mbps</li> </ul>
2.2.2.6	Media Access Protocol	<ul style="list-style-type: none"> <li>CSMA/CA with ACK</li> </ul>
2.2.2.7	Transmitter Output Power before Antenna	<ul style="list-style-type: none"> <li>Typical RF Output Power (tolerance : <math>\pm 2</math> dBm) and Data Rate at each RF chain, at room Temp. 25degree C</li> <li>10 dBm</li> </ul>
2.2.2.8	Receiver Sensitivity before Antenna	<ul style="list-style-type: none"> <li>Typical Sensitivity at Which Frame (1000-byte PDUs) Error Rate = 10%</li> <li>-82 dBm at 6Mbps</li> <li>-81 dBm at 9Mbps</li> <li>-79 dBm at 12Mbps</li> <li>-77 dBm at 18Mbps</li> <li>-74 dBm at 24Mbps</li> <li>-70 dBm at 36Mbps</li> <li>-66 dBm at 48Mbps</li> <li>-65 dBm at 54Mbps</li> </ul>

### 2.2.3 IEEE 802.11 final n Section

#	Feature	Detailed Description				
2.2.3.1	Standard	<ul style="list-style-type: none"> <li>Final n</li> </ul>				
2.2.3.2	Radio and Modulation Type	<ul style="list-style-type: none"> <li>BPSK, QPSK, 16QAM, 64QAM with OFDM</li> </ul>				
2.2.3.3	Operating Frequency	<ul style="list-style-type: none"> <li>2400 ~ 2483.5MHz ISM band</li> </ul>				
2.2.3.4	Data Rate	<ul style="list-style-type: none"> <li>TX: MCS0 ~ MCS7</li> <li>RX: MCS0 ~ MCS7</li> </ul>				
		MCS	GI=800ns		GI=400ns	
			20MHz	40MHz	20MHz	40MHz
		0	6.5	13.5	7.2	15
		1	13	27	14.4	30
		2	19.5	40.5	21.7	45
		3	26	54	28.9	60
		4	39	81	43.3	90
		5	52	108	57.8	120
		6	58.5	121.5	65.0	135
		7	65	135	72.2	150
2.2.3.5	Media Access Protocol	<ul style="list-style-type: none"> <li>CSMA/CA with ACK</li> </ul>				
2.2.3.6	Transmitter Output Power before Antenna	<ul style="list-style-type: none"> <li>Typical RF Output Power (tolerance : <math>\pm 2</math> dBm) and Data Rate at each RF chain, at room Temp. 25degree C</li> <li>10 dBm</li> </ul>				
2.2.3.7	Receiver Sensitivity before Antenna	<ul style="list-style-type: none"> <li>Typical Sensitivity at Which Frame (1000-byte PDUs) Error Rate <math>\leq 10\%</math></li> <li>HT20</li> <li>-80 dBm at MCS0</li> <li>-77 dBm at MCS1</li> <li>-75 dBm at MCS2</li> <li>-72 dBm at MCS3</li> <li>-68 dBm at MCS4</li> <li>-64 dBm at MCS5</li> </ul>				

#	Feature	Detailed Description
		<ul style="list-style-type: none"> <li>-63 dBm at MCS6</li> <li>-62 dBm at MCS7</li> </ul> HT40 <ul style="list-style-type: none"> <li>-79 dBm at MCS0</li> <li>-76 dBm at MCS1</li> <li>-74 dBm at MCS2</li> <li>-71 dBm at MCS3</li> <li>-68 dBm at MCS4</li> <li>-64 dBm at MCS5</li> <li>-62 dBm at MCS6</li> <li>-60 dBm at MCS7</li> </ul>

### 2.2.4 General Section

#	Feature	Detailed Description
2.2.4.1	Antenna Type	<ul style="list-style-type: none"> <li>Integrated antenna</li> </ul>
2.2.4.2	Operating Voltage	<ul style="list-style-type: none"> <li>3.3VDC+/- 10%</li> </ul>
2.2.4.3	Current Consumption	<ul style="list-style-type: none"> <li>3.3V:240 mA</li> <li>1.5V:210 mA</li> </ul>
2.2.4.4	USB	<ul style="list-style-type: none"> <li>High Speed USB2.0 Interface</li> </ul>

### 2.3 Mechanical Requirements

#	Feature	Detailed Description
2.3.1	Length	<ul style="list-style-type: none"> <li>28mm (PCBA) (include place for screw) (customer spec)</li> </ul>
2.3.2	Width	<ul style="list-style-type: none"> <li>13mm (PCBA) (customer spec)</li> </ul>
2.3.3	Height	<ul style="list-style-type: none"> <li>3mm (PCBA) (customer spec)</li> </ul>

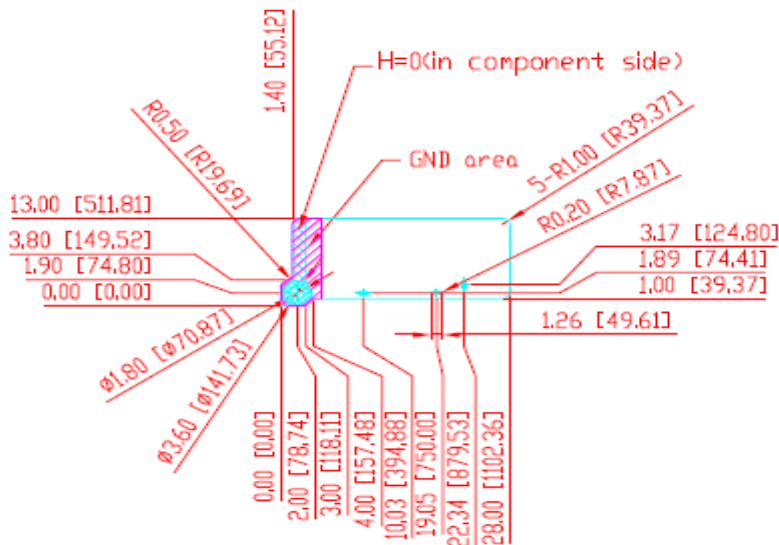

### 2.4 Requirements of Reliability, Maintainability and Quality

#	Feature	Detailed Description
2.4.1	MTBF	<ul style="list-style-type: none"> <li>Mean Time Between Failure &gt; 30,000 hours</li> </ul>





#	Feature	Detailed Description
2.4.2	Maintainability	<ul style="list-style-type: none"><li>There is no scheduled preventive maintenance required</li></ul>
2.4.3	Quality	<ul style="list-style-type: none"><li>The product quality is followed-up by ALPHA factory quality control system</li></ul>

## 2.5 Environmental Requirements

#	Feature	Detailed Description
2.5.1	Operating Temperature Conditions	<ul style="list-style-type: none"><li>The product is capable of continuous reliable operation when operating in ambient temperature of 0 °C to +55 °C</li></ul>
2.5.2	Non-Operating Temperature Conditions	<ul style="list-style-type: none"><li>Neither subassemblies is damaged nor the operational performance is degraded when restored to the operating temperature after exposing to storage temperature in the range of -20 °C to +75 °C.</li></ul>
2.5.3	Operating Humidity conditions	<ul style="list-style-type: none"><li>The product is capable of continuous reliable operation when subjected to relative humidity in the range of 10% and 90% non-condensing.</li></ul>
2.5.4	Non-Operating Humidity Conditions	<ul style="list-style-type: none"><li>The product is not damaged nor the performance is degraded after exposure to relative humidity ranging from 5% to 95% non-condensing</li></ul>

## 2.6 Regulatory

FCC, IC, TELEC, CE...etc